

**City of Fayetteville Staff Review Form**

**2015-0239**

**Legistar File ID**

**6/2/2015**

City Council Meeting Date - Agenda Item Only  
N/A for Non-Agenda Item

Jeremy Pate

5/15/2015

Development Services /  
Development Services Department

**Submitted By**

**Submitted Date**

**Division / Department**

**Action Recommendation:**

AN ORDINANCE TO AMEND § 174.07 PLACING SIGNS ON PUBLIC AND PRIVATE PROPERTY BY CLARIFYING THE PLACEMENT OF DIRECTIONAL AND WAYFINDING SIGNS ON PUBLIC PROPERTY AND ENACTING A NEW SUBSECTION (F) TRAIL/TRAILHEAD WAYFINDING SIGNS AND RECOGNITION MARKERS.

**Budget Impact:**

Account Number	Fund
Project Number	Project Title
<b>Budgeted Item?</b> <u>NA</u>	Current Budget            \$            -
	Funds Obligated            \$            -
	Current Balance            \$            -
<b>Does item have a cost?</b> <u>No</u>	Item Cost
<b>Budget Adjustment Attached?</b> <u>NA</u>	Budget Adjustment
	Remaining Budget            \$            -

V20140710

Previous Ordinance or Resolution # \_\_\_\_\_

Original Contract Number: \_\_\_\_\_

Approval Date: \_\_\_\_\_

Comments:

**MEETING OF JUNE 02, 2015**

**TO:** Mayor and City Council

**THRU:** Don Marr, Chief of Staff

**FROM:** Jeremy Pate, Development Services Director 

**DATE:** May 12, 2015

**SUBJECT:** Wayfinding and Trail Signs

---

**RECOMMENDATION:**

Staff recommends that the Unified Development Code §174.07 be amended to permit a variety of coordinated informational, interpretive and wayfinding signs to be installed along the Razorback Greenway regional trail, and along other multi-use trails in the future. With this amendment, small recognition emblems would be permitted on these signs for non-profits or governmental organizations that substantially participate in the organization or funding to make the trail system a reality.

**BACKGROUND:**

The highly anticipated Razorback Regional Greenway trail was officially opened on May 02, 2015. This 37-mile multi-use trail connects south Fayetteville with north Bentonville, traveling through the cities of Johnson, Springdale, Lowell and Rogers in between. The project was made possible through the organization and funding of the participating cities, the Northwest Arkansas Regional Planning Commission, a federal grant and private funding sources, most notably the Walton Family Foundation. The City benefited directly from these contributions with the design and construction of the southern and northern extensions of the trail, valued at approximately \$3.9 million. We continue to seek out ways to leverage our local taxpayer funds for other multi-use trails on the City's Master Plan, connecting the future Regional Park and other destinations to the Regional Greenway system.

In addition to the construction of the greenway itself, the cities have again collaborated to create a regional trail wayfinding, interpretive and informational sign plan. Similar to the wayfinding sign program utilized along our roads and sidewalks, the trail signs share a common design theme that enhances the shared collaborative effort and provides cohesive, consistent messaging for users. The first phase are mile markers fabricated and installed along the 37 miles of trail. Each city funded their own mile markers, and the Regional Planning Commission coordinated all of the procurement process and contract management. These mile markers serve as wayfinding signs, allowing recreational users and travelers the ability to know how far they have travelled, but also for first responders and others who need to quickly determine the location on the trail where someone may need assistance. There are 10 mile markers installed in Fayetteville, beginning at Mile Marker "0", the beginning of the trail in south Fayetteville. While

funding has not been identified, a system of additional signage planned to be installed along the trail system in the future can be seen in the attached draft design packet.

**DISCUSSION:**

The City's ordinance permits signs to be placed on public property under certain conditions. It does not permit advertising of any kind. However, the current ordinance was written primarily to allow installation of traditional street signs, traffic signs, etc. and not wayfinding signs along a trail system. After discussion with the City Attorney, staff felt it was best to present an ordinance amendment to state the purpose of the informational and interpretive wayfinding signs along the trail system and to also be transparent about the intent to include a small recognition logo of the primary supporters of our regional trail system, as part of this project and others in the future that may occur. In addition, the term "wayfinding" has been added to this section of the ordinance to clarify the use of these types of signs in our pedestrian and vehicular environments.

**BUDGET/STAFF IMPACT:**

None

**Attachments:**

- Map of regional trail and mile marker drawings

## Proposed Ordinance

### Exhibit "A"

#### 174.07 Placing Signs on Public Property

No signs other than signs placed by agencies of government shall be erected on any public property or right-of-way.

(A) *Directional and Wayfinding Signs.* Directional and wayfinding signs may be erected on public property or within the city's street right-of-way under the following conditions:

- (1) The signs direct the reader to the location of a public or educational institution, to a facility operated by a nonprofit entity and attended by out-of-town patrons, to a facility relating to the public health, safety, or welfare, or to scenic or historic buildings, trails and parks;
- (2) The signs are fabricated, erected and maintained by the City or its agent.
- (3) The signs are installed at locations where they would not constitute a traffic hazard.
- (4) The signs have been approved and permitted as required by the authority having jurisdiction; and
- (5) The maximum number of directional signs permitted under this section shall be seven (7) for each entity; provided, the limitation provided hereby shall not apply to signs directing the reader to scenic or historic buildings, trails and parks.

(B) *Nonprofit organizations.* Nonprofit organizations may be allowed to place temporary signs of a noncommercial nature on public property for the purpose of directing the general public to the location of an event or activity which promotes the general public welfare. The placement of such temporary signs shall be subject to the following conditions:

- (1) The maximum display surface area of each sign shall not exceed fifteen (15) square feet;
- (2) No more than three (3) signs directing the general public to such an event or activity shall be placed on public property at the same time by one such organization;
- (3) Each such sign shall identify the nonprofit organization by name;
- (4) No such temporary sign shall be placed on public property for more than five (5) successive days;
- (5) *Location/approval.* The location of each such sign shall be approved by the Planning and Zoning Administration or designee to ensure

that the signs will not constitute a traffic hazard;

(6) *Permit/number of signs.* The organization applies for, and is issued, a sign permit; one permit may authorize installation of up to three (3) signs pursuant to the provisions of this division; and

7) *Temporary signs.* No such organization shall install, or be issued a permit to install a temporary sign on public property pursuant to the provisions of this division more often than six (6) times within a 12-month period.

(C) *Small banners on certain city light poles.* The City or the Mayor's designee may prepare and install banners not exceeding seven square feet on city light poles specially designed and constructed for such banners within the boundaries of the Downtown Master Plan Area. These small banners may include the name of the commercial or noncommercial enterprise sponsoring the banner, but shall contain no advertising or slogans of the sponsor.

(D) *Informational kiosks.* Informational kiosks with a map of the Downtown Master Plan Area may be placed within city right-of-way by the City. The kiosks shall contain a map and/or description of the Downtown Master Plan Area, public buildings and facilities, parking areas, and entertainment, cultural, and historic facilities within or near this zone.

(E) *Cross Street Banners.* Cross Street Banners may be installed pursuant to §174.03 (J) (3) (b).

(F) *Trail/Trailhead wayfinding signs and recognition markers.* Trail mileage markers, directional and wayfinding signs, informational and interpretive signs, and other such regionally coordinated signage may be installed on the Regional Greenway Trail corridor or other public multi-use trail corridors within the city, under the following conditions:

(1) All signs shall be coordinated to provide clear messaging related to the use, safety, and enjoyment of the trail or trailhead.

(2) Small recognition emblems for non-profits or governmental organizations may be located on the trail signs, provided the non-profit or governmental organization substantially participated in the funding or coordinated the installation of the trail and/or trailhead. Signs may not include advertising or slogans of sponsors.

## 174.07 Placing Signs On Public And Private Property

### (A) *Placing signs on public property.*

(1) *Agencies of government.* No signs other than signs placed by agencies of government shall be erected on any public property; provided, directional signs may be erected upon the city's street name signposts, or upon traffic signposts under the following conditions:

- (a) *Public facility/ out-of-town patrons.* The signs direct the reader to the location of a public facility attended principally by out-of-town patrons, to a facility operated by a nonprofit entity and attended principally by out-of-town patrons, to a facility relating to the public health, safety, or welfare, or to scenic or historic trails;
- (b) *Traffic Division.* The signs are fabricated, erected and maintained by the city Transportation Division;
- (c) *Cost.* The entire cost of the signs is borne by the entity requesting the signs;
- (d) *Installation.* The signs are installed at locations where they would not constitute a traffic hazard.
- (e) *Traffic control devices.* The signs conform to the manual on uniform traffic-control devices; and
- (f) *Directional signals.* The maximum number of directional signs permitted under this section shall be seven (7) for each entity; provided, the limitation provided hereby shall not apply to signs directing the reader to scenic or historic trails.

(2) *Nonprofit organizations.* Nonprofit organizations shall be allowed to place temporary signs of a noncommercial nature on public property for the purpose of directing the general public to the location of an event or activity which promotes the general public welfare. The placement of such temporary signs shall be subject to the following conditions:

- (a) *Display surface area.* The maximum display surface area of each sign shall not exceed fifteen (15) square feet;
- (b) *Number of signs.* No more than three (3) signs directing the general public to such

an event or activity shall be placed on public property at the same time by one such organization;

(c) *Organization name.* Each such sign shall identify the nonprofit organization by name;

(d) *Temporary sign.* No such temporary sign shall be placed on public property for more than five (5) successive days;

(e) *Location/approval.* The location of each such sign shall be approved by the Planning and Zoning Administration or designee to ensure that the signs will not constitute a traffic hazard;

(f) *Permit/number of signs.* The organization applies for, and is issued, a sign permit; one permit may authorize installation of up to three (3) signs pursuant to the provisions of this division; and

(g) *Temporary signs.* No such organization shall install, or be issued a permit to install a temporary sign on public property pursuant to the provisions of this division more often than six (6) times within a 12-month period.

(3) *Small banners on certain city light poles.* The City may prepare and install banners not exceeding seven square feet on city light poles specially designed and constructed for such banners within the boundaries of the Downtown Master Plan Area. These small banners may include the name of the commercial or noncommercial enterprise sponsoring the banner, but shall contain no advertising or slogans of the sponsor.

(4) *Informational kiosks.* Informational kiosks with a map of the Downtown Master Plan Area may be placed within city right-of-way by the City. The kiosks shall contain only a map and/or description of the Downtown Master Plan Area, public buildings and facilities, parking areas, and entertainment facilities within or near this zone.

(5) *Cross Street Banners.* Cross Street Banners may be installed pursuant to §174.03 (J) (3) (b).

(Code 1965, §17B-7(c); Ord. No. 1893, 12-19-72; Ord. No. 2934, 8-2-83; Ord. No. 2948, 9-20-83; Ord. No. 3298, 10-6-87; Code 1991, §159.37; Ord. No. 3677, §1, 3-2-93; Ord. No. 4100, §2 (Ex. A), 6-16-98; Ord. No. 4622, 9-21-04; Ord. 4972, 1-16-07)

DESIGN

GUIDELINES

STANDARDS

PLACEMENT



# Wayfinding Master Plan

FEBRUARY 2015



# TABLE OF CONTENTS

<b>1</b>	<b>INTRODUCTION</b>	
	Wayfinding for the Razorback.....	4
<b>2</b>	<b>BRANDING, IDENTITY, AND STANDARDS</b>	
	Logo and Colors.....	5
	Partner Logos.....	5
<b>3</b>	<b>RAZORBACK GREENWAY SIGN SYSTEM</b>	
	Sign Family.....	6
	Information Kiosk.....	8
	Trailhead I.D.....	12
	Trail Map Signs.....	16
	Community Guides.....	20
	Directionals.....	24
	Mile Markers.....	28
	Walk/Bike Distance and Time.....	32
	Confidence Markers.....	36
	Interpretive Displays.....	40
<b>4</b>	<b>SYSTEMWIDE LOCATION MASTER PLAN</b>	
	Overview.....	44
	Fayetteville.....	46
	Springdale.....	50
	Lowell.....	54
	Rogers.....	58
	Bentonville.....	62
<b>5</b>	<b>ALTERNATIVE SOFT SURFACE SIGNAGE</b>	
	Sign Family.....	64
	Information Kiosk/Trailhead.....	66
	Destination and Directional Signage.....	68
	Permitted Uses/Trail Rules and Regulatory Signage.....	70
	On-Trail Directional & Confidence Markers.....	72
	Informational Display / Trail Map.....	74
	Alternative Soft Surface Signage Guidelines.....	78





# INTRODUCTION

## WAYFINDING FOR THE RAZORBACK

A comprehensive wayfinding system should be approached from both recreation and transportation perspectives. As the system of interconnected greenways, natural trail systems, on-road bicycle facilities, and sidewalks expand, residents and visitors will be able to access longer recreation routes, schools, commercial centers, and green spaces without using personal motor vehicles. The Razorback Regional Greenway will become an integral component of Northwest Arkansas infrastructure. Signage increases the usability of the trail system as well as each city. Users will begin to navigate Fayetteville, Springdale, Rogers, Lowell, and Bentonville via a network of trails and spurs. To enhance the function of navigation and contribute to economic development, signage should be placed along the trail with walk and bike distances and times to commercial centers, restaurants, and retail establishments.

Components of a successful wayfinding system include standards for logos, color, typography, and symbols. All of these elements create an identity package for sign types, such as trailhead identification, trail markers, mile markers, pedestrian directionals, regulatory signage, confidence markers, interpretive signage, and information kiosks. All maps should employ the same symbology, fonts, color system, and style.

This Plan provides a guide for all sign design and placement. Typical details are included for installation and map creation. All communities within the trail system will be co-branded on the Razorback Regional Greenway signage package.

Any questions about standards, design, application, installation, or updates to the Razorback family of signs should be directed to directed to Misty Murphy, Regional Trail Coordinator.



# BRANDING, IDENTITY, AND STANDARDS

## LOGO AND COLORS

The Razorback Greenway has one primary logo and four approved alternatives. The Solid Color Logo must comply with the approved PANTONE color palette. Grayscale, and Black and White Versions should be used on a solid white background. When solid white is not possible, it is acceptable to place a white circle around the logo with a buffer of white appearing around the outer lettering.

The font used in the logo is Today BEF and should never be altered or changed. Versions of the logo are available in .ai and .eps with the fonts outlined. The logo should not be reproduced or duplicated without the approved vectorized typeface.

## PARTNER LOGOS

In addition to the Razorback Greenway logo, partner logos will appear on the signage package. The Walton Family Foundation and Northwest Arkansas Regional Planning Commission will appear as the major funding contributor and organizing agency, respectively. City and Town logos aid in user orientation and unite the trail as a regional transportation and recreation facility. Each municipality will have their logo placed on the Razorback signage where the trail passes through their boundary. Acceptable formats of partner logos are below. (See each sign design for placement and sizing standards).



Primary Logo

PANTONE Colors



Other Acceptable Logo Versions



Solid Color Logo



Grayscale Logo



Black and White Version 1



Black and White Version 2





# RAZORBACK GREENWAY SIGN SYSTEM

## SIGN FAMILY

The Razorback Greenway sign family creates a cohesive identity for the entire 36-mile system. The colors, fonts, symbology and design of each sign have been crafted to improve navigation, encourage use, and provide an identity for the trail. Sign types include regulatory information, regional and cultural details, identification markers, walk and bike timing, and geographical references. Each component works together to complete a system of comfortable spaces for multiple types of walker and cyclists.

Recreation, fitness, and transportation users are considered when placing each sign type. Community Signs direct users toward the trail and indicates to non-users the proximity and ease of access to the greenway.

As areas surrounding the greenway are developed, directionals should be placed within neighborhoods and commercial centers to inform citizens and visitors of the opportunity to recreate or use the trails as an alternative to motor vehicle transportation.



# RAZORBACK GREENWAY SIGN SYSTEM



TRAILHEAD I.D.

MILE MARKER

MAP

WALK/BIKE DESTINATION AND DIRECTIONAL

CONFIDENCE MARKER

INTERPRETIVE SIGN

INFORMATION KIOSK

COMMUNITY GUIDE



# RAZORBACK GREENWAY SIGN SYSTEM

## INFORMATION KIOSK

Information Kiosks will be placed at each trailhead, and located at key points along the trail to serve as system-wide education tools, trip planning devices, regulatory information centers, and interpretive signage. Maps should include the entire greenway and indicate where the user is located within the system. Logos for each community shall be placed at the base of the sign to further identify user location and co-brand the system with any adjacent navigation efforts by the community.



ELEVATION

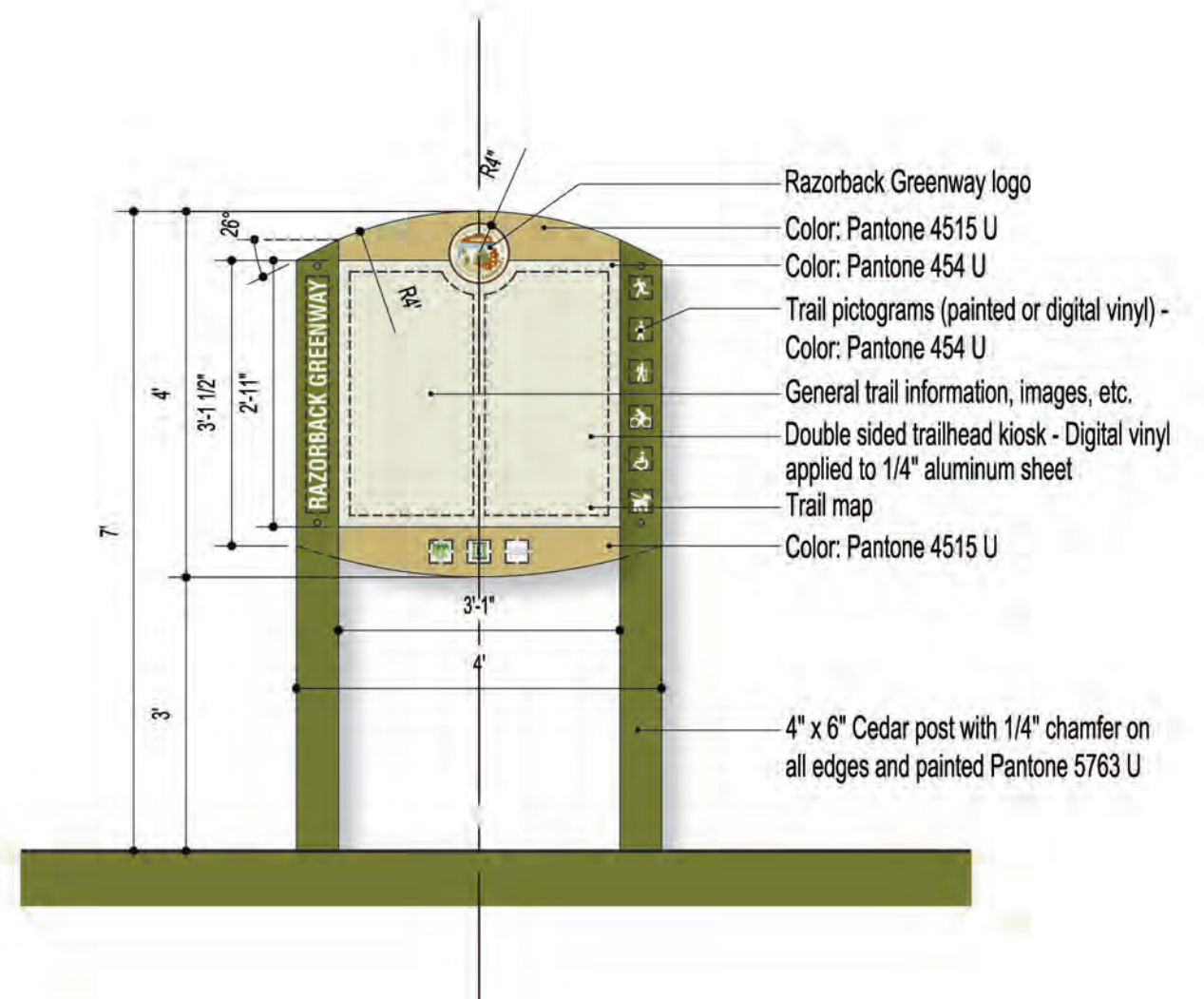

OVERALL DIMENSIONS

# RAZORBACK GREENWAY SIGN SYSTEM

## INFORMATION KIOSK

### TYPOGRAPHY

**Vertical "RAZORBACK GREENWAY" banner**

- Font = Helvetica LT - Bold Condensed
- Align = Center
- Size = 3"
- Color = Pantone 454 U

**Informational Text - Header**

- Font = Helvetica LT - Bold
- Align = Center
- Size = 3/4"
- Color = Pantone 7517 U

**Informational Text - Body**

- Font = Helvetica LT - Light
- Align = Fully justified
- Size = 5/8"
- Color = Pantone 7517 U

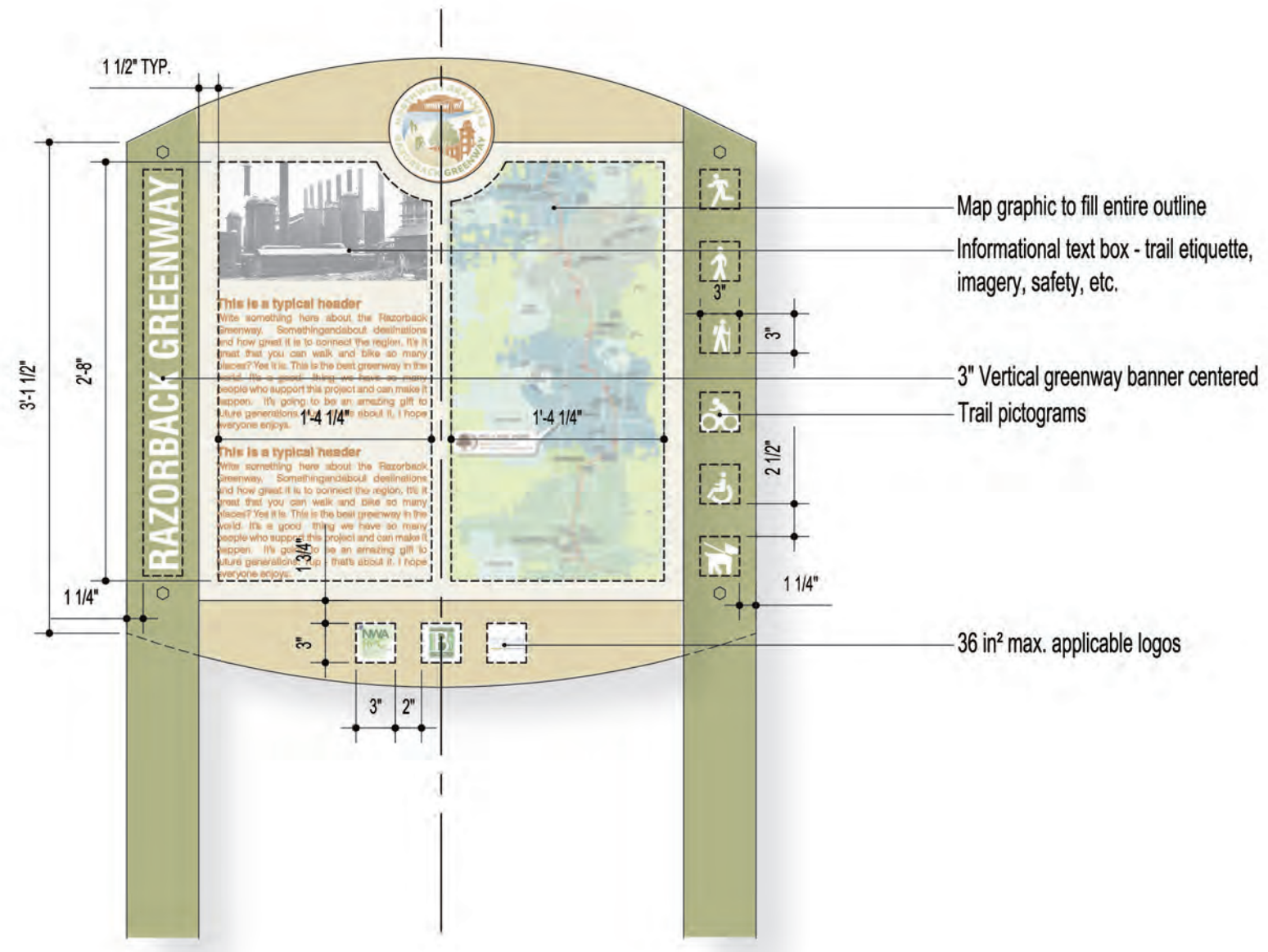

GRAPHIC LAYOUT



# RAZORBACK GREENWAY SIGN SYSTEM

## INFORMATION KIOSK

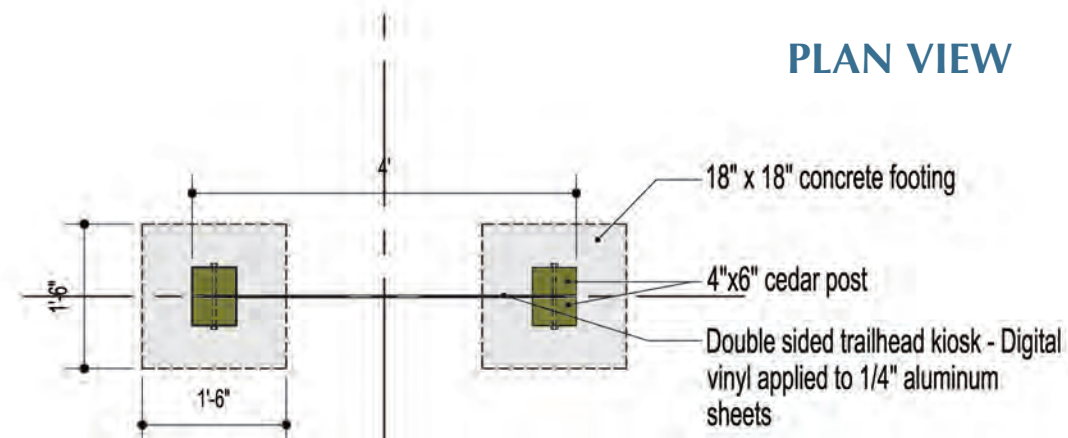

## TRAIL USE RULES AND REGULATIONS

The following trail rules and regulations should be posted on the rear side of the kiosk.

### Rules For Trail Use

- Hours of Operation - Trails Open Sunrise to Sunset
- No Motorized Vehicles on Trails
- Be Courteous to Other Trail Users - Share the Trail
- Always Walk or Bike with a Friend – Use the Buddy System
- Don't Block the Trail – Walk and Bike Single File
- Always Keep to the Right hand side of the Trail
- Faster Users Pass on the Left
- Give Audible Signal When Passing
- Bicyclists Yield Right of Way to Pedestrians
- Clean Up Your Litter – Take Your Trash With You
- Keep Pets on Leashes At All Times
- Immediately Remove All Pet Waste from Trail Corridor
- No Alcohol or Drug Use Allowed
- No Removal of Flowers, Shrubs, Trees or Animals
- No Firearms Allowed on Trails
- No Overnight Camping or Fires
- No Trespassing on Adjacent Property

Trail Use Rules and Regulations adopted pursuant to City of \_\_\_\_\_ ordinance. All city, county, state and federal laws are applicable to use of trails.

Enjoy The Trail!

# RAZORBACK GREENWAY SIGN SYSTEM

## TYPICAL INFORMATION KIOSK PLACEMENT

Where there are trailheads with parking areas, the sign should be located at or near the access path from the parking area to the trail. If the trail is visible from the parking area, then it is recommended that the sign be placed adjacent to the trail.

Orientation of the sign is to be perpendicular to the trail or path of travel.

Positioning of the sign should be based on existing landscaping. The diagram shows the preferred location. Keep the sign a minimum of 3 feet from edge of circulation surfaces.

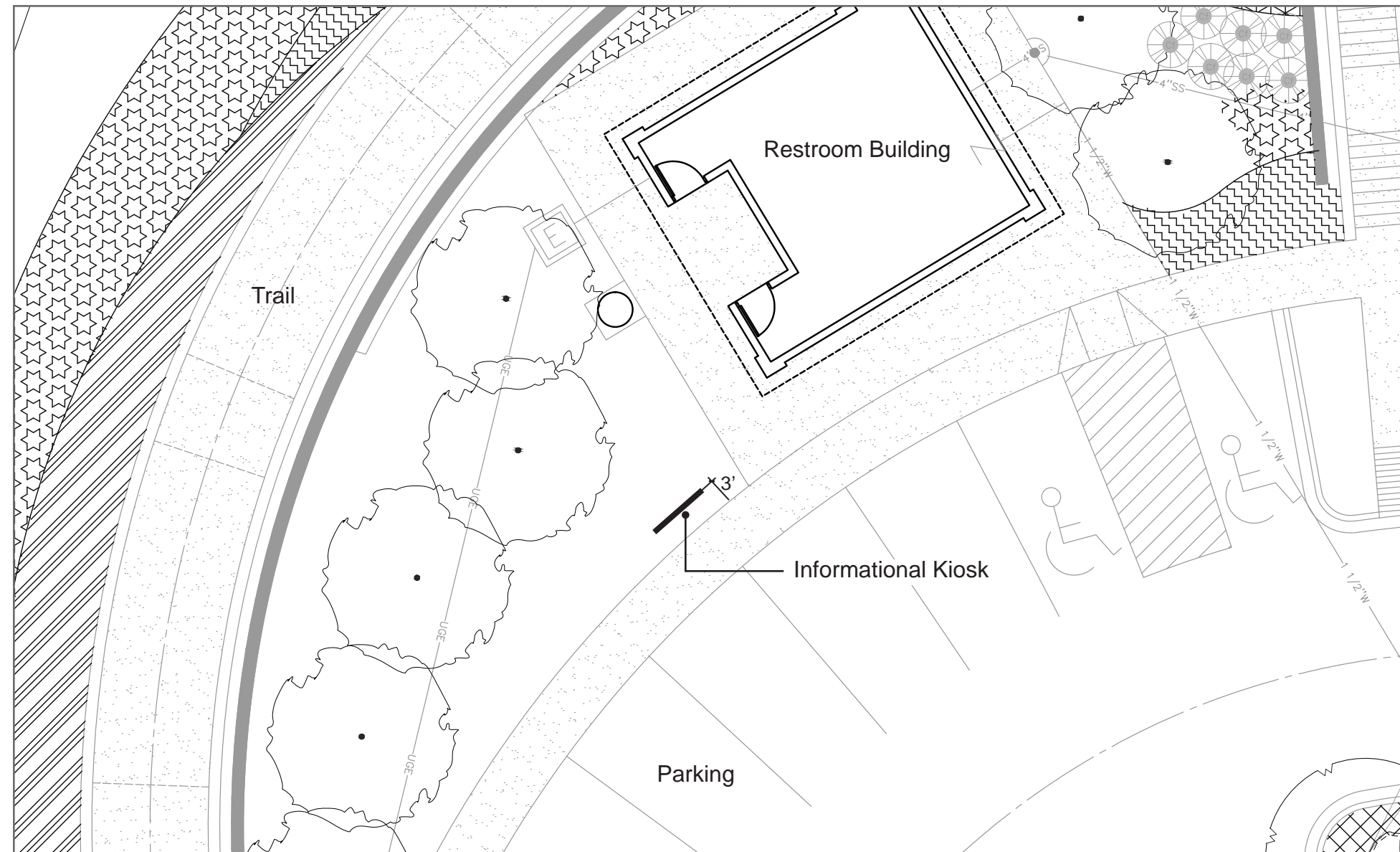





# RAZORBACK GREENWAY SIGN SYSTEM

## TRAILHEAD I.D.

Trailhead I.D. signs indicate where vehicles can access trailheads and where pedestrians and cyclists may access the trail at key intersections. Co-branding for each city is located along the base of the sign.



ELEVATION



# RAZORBACK GREENWAY SIGN SYSTEM

## TRAILHEAD I.D.

### OVERALL DIMENSIONS

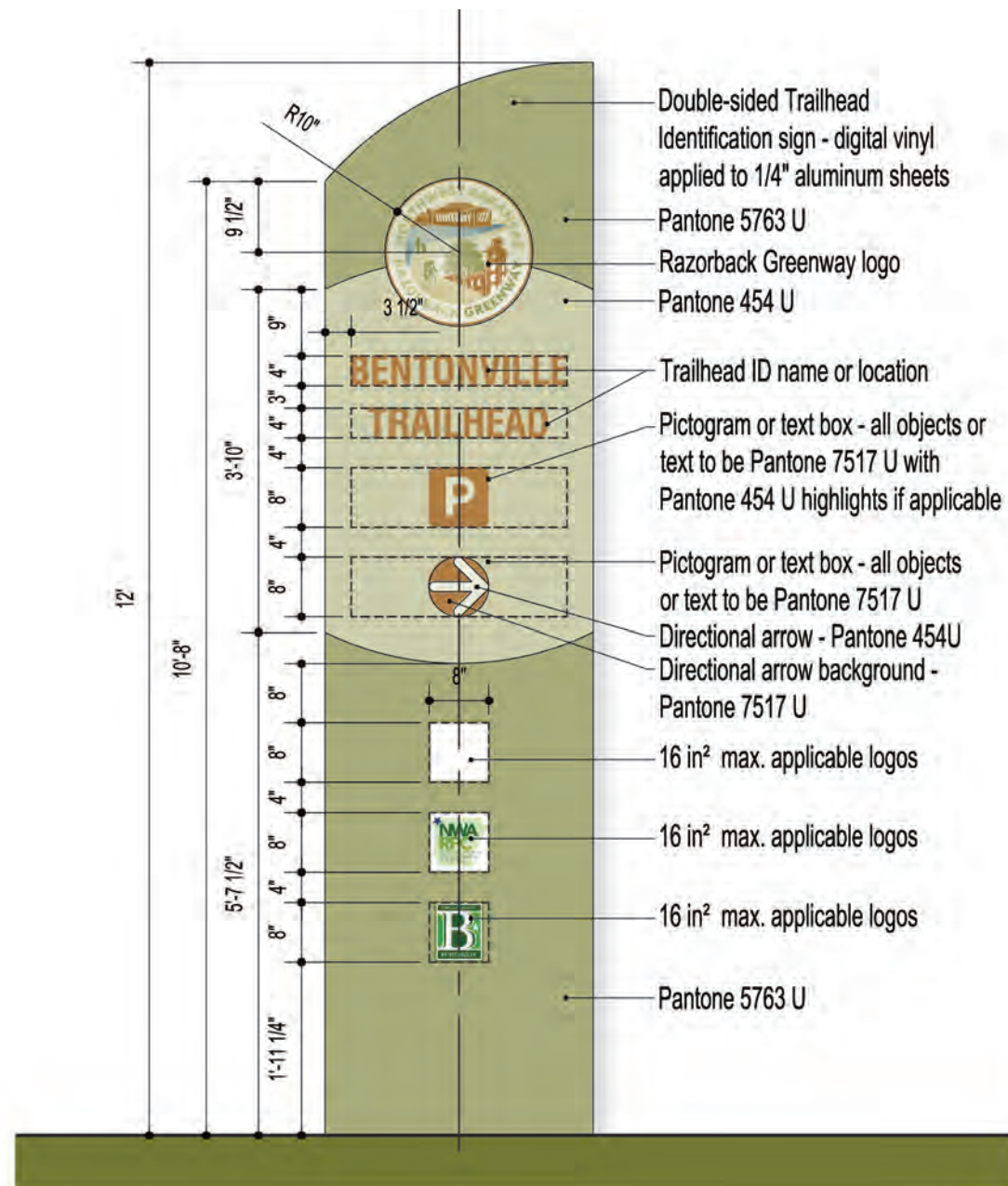

### TYPOGRAPHY

#### Trailhead ID or location text

- Font = Helvetica LT - Bold Condensed
- Align = Center
- Size = 4"
- Tracking = -10
- Color = Pantone 7517 U



# RAZORBACK GREENWAY SIGN SYSTEM

TRAILHEAD I.D.

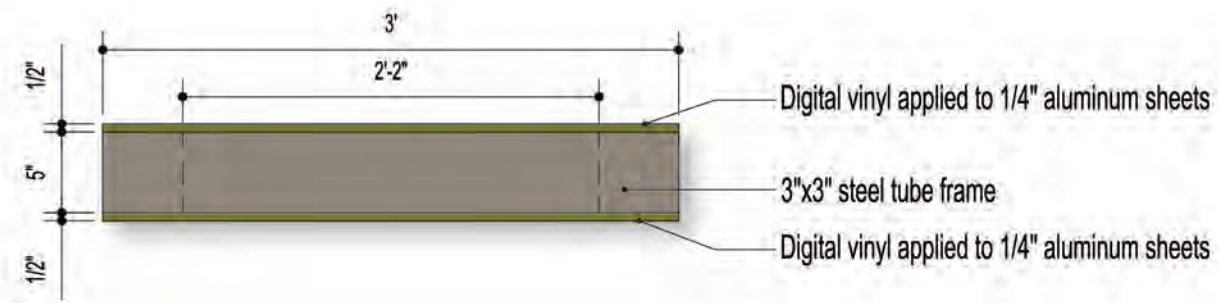

PLAN VIEW

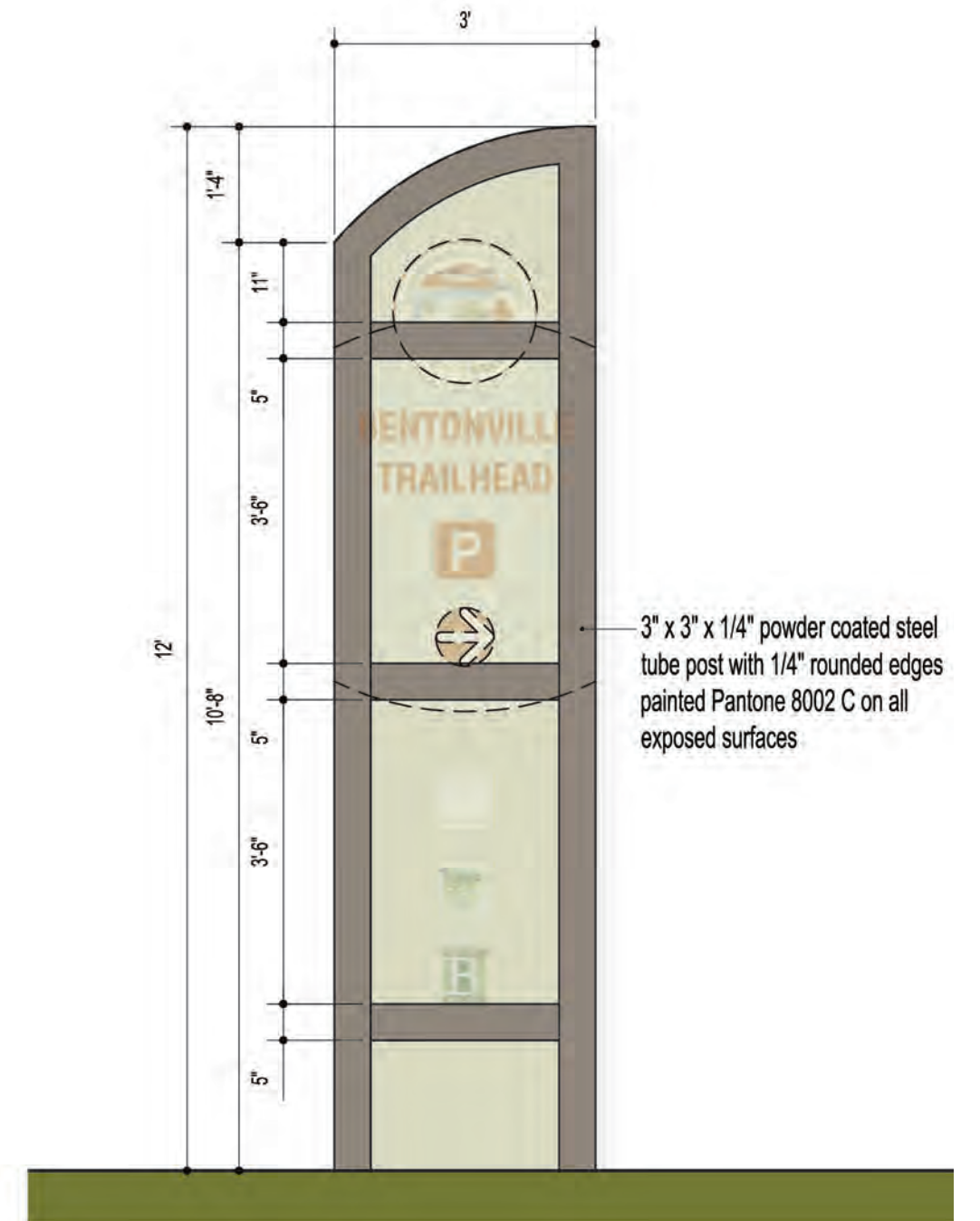

FRAME

# RAZORBACK GREENWAY SIGN SYSTEM

## TYPICAL TRAILHEAD I.D. PLACEMENT

This sign option is intended as a primary trail identification sign for greenways with parking facilities at the trailhead.

Sign must be placed behind site triangle as illustrated.

The sign must be placed a minimum of 10-feet from the roadway right-of-way.

Orientation of the sign is to be perpendicular to the public street.

The sign may be placed on either side of the entrance. The preferred location is on the right side as the vehicle faces the trailhead entrance.

Try to maintain a clear line of sight from the roadway and sidewalk (if present) to the sign on both sides of the trailhead entrance.

Do not place landscape at the base of this sign.

This sign will require permitting prior to installation.

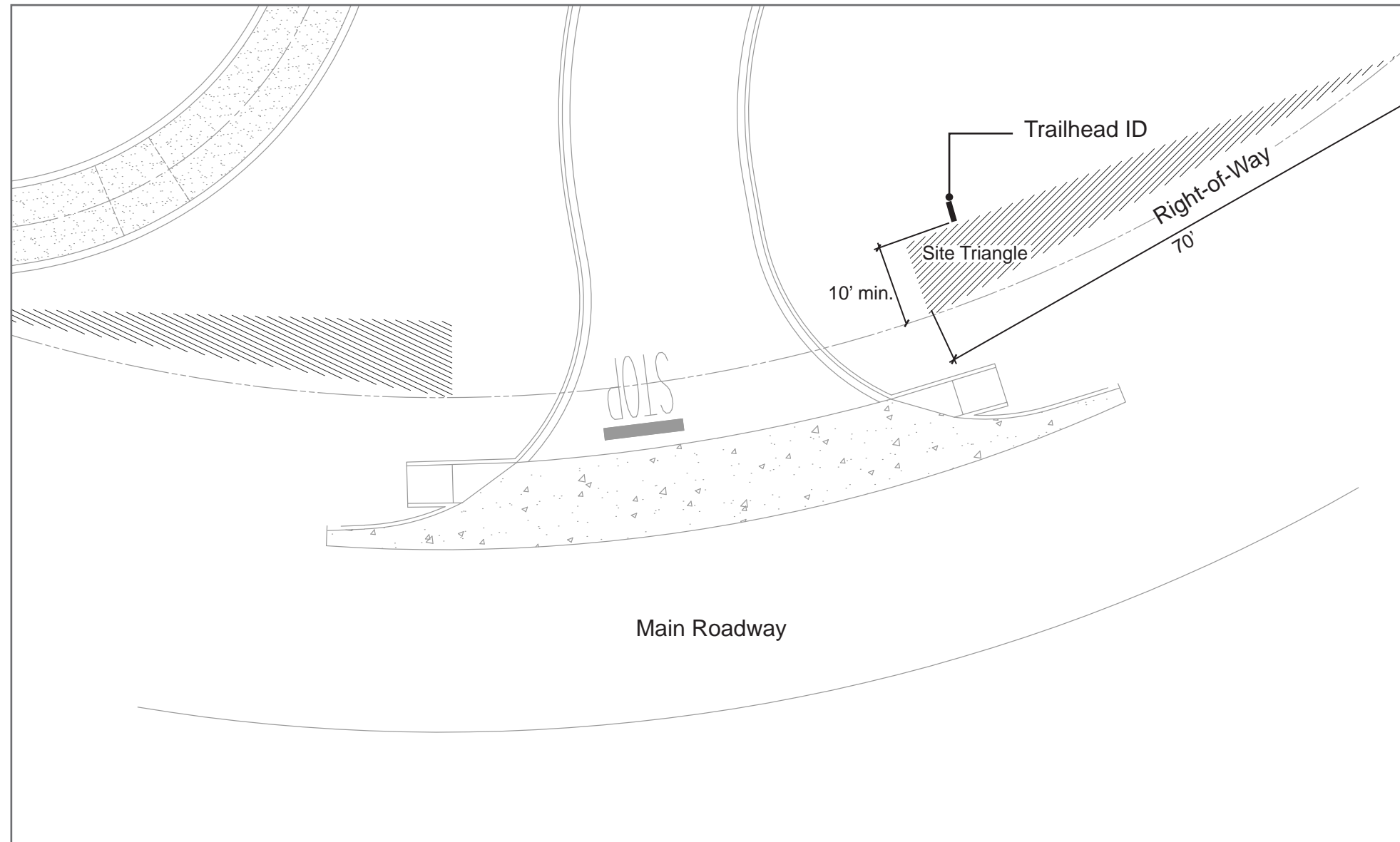



# RAZORBACK GREENWAY SIGN SYSTEM

## TRAIL MAP SIGNS

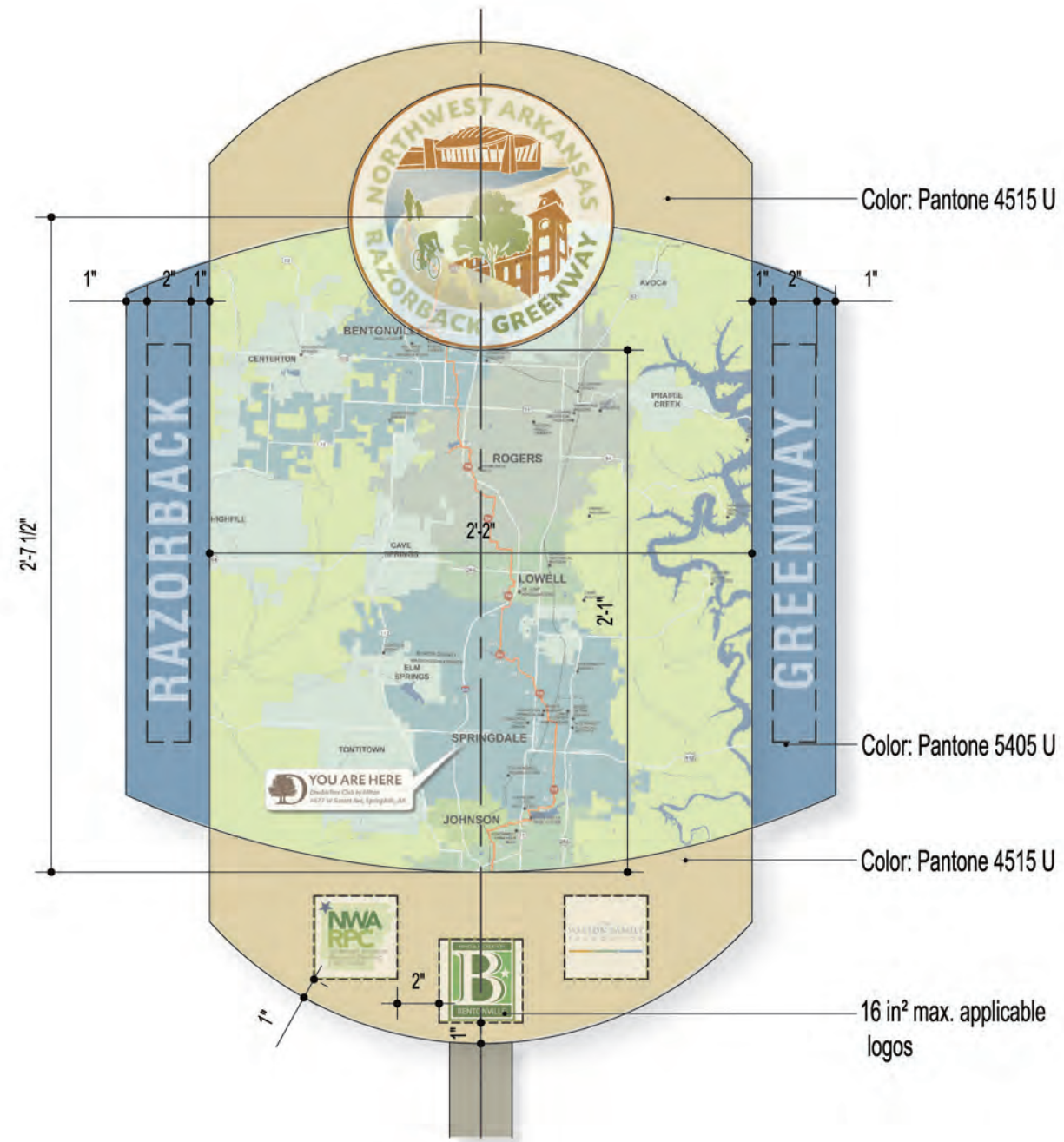

GRAPHIC LAYOUT

### TYPOGRAPHY

**Vertical "RAZORBACK GREENWAY" banner**

- Font = Helvetica LT - Bold Condensed
- Align = Center
- Size = 2"
- Tracking = 100
- Color = Pantone 454 U



# RAZORBACK GREENWAY SIGN SYSTEM

## TRAIL MAP SIGNS

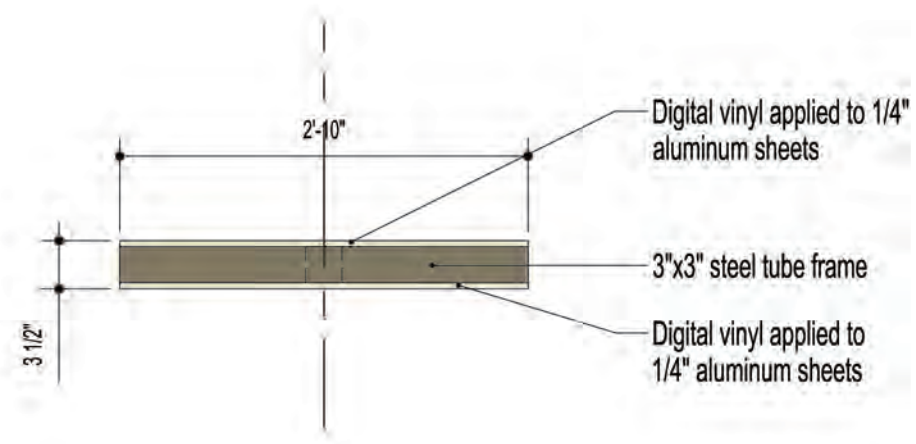

PLAN VIEW

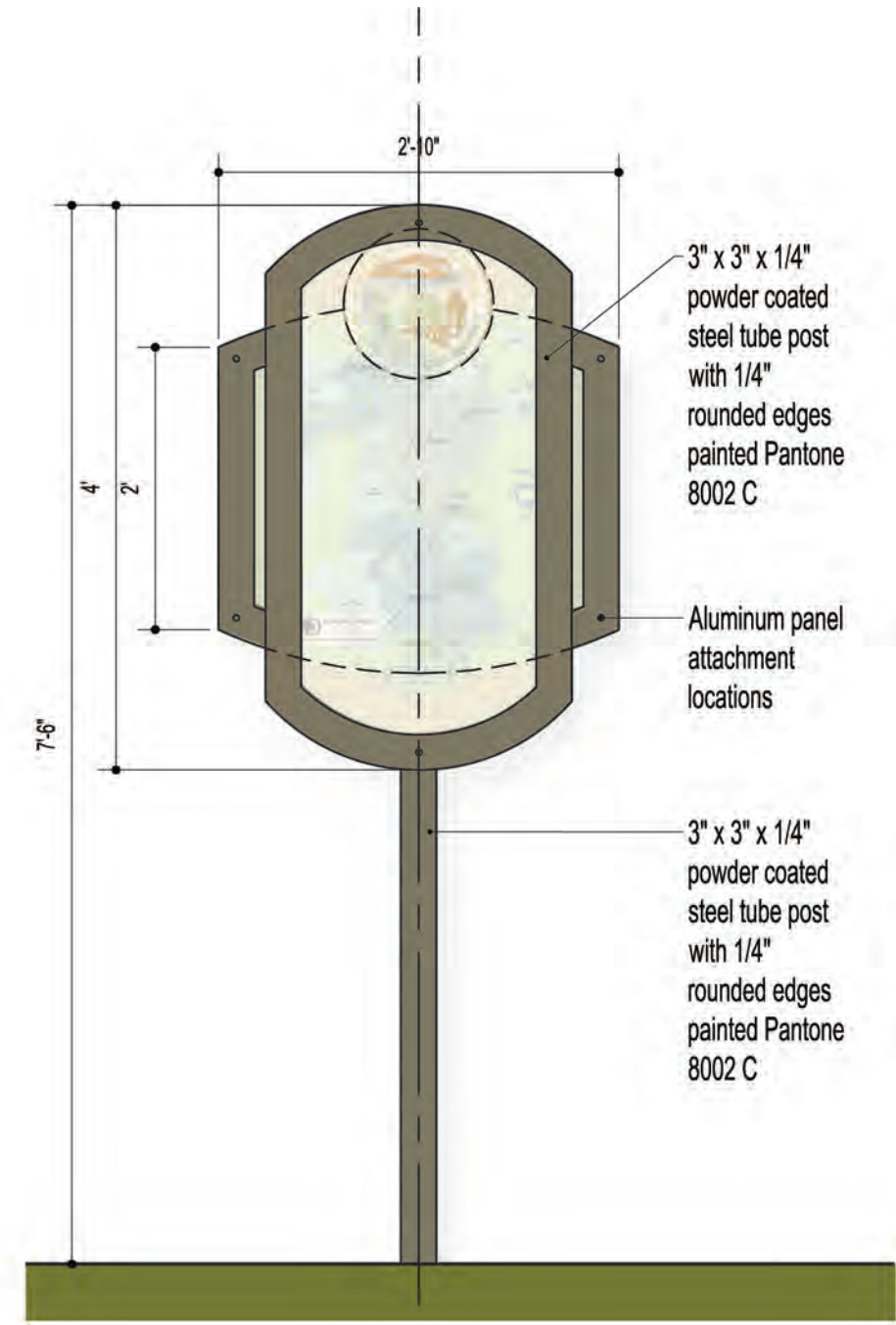

FRAME

# RAZORBACK GREENWAY SIGN SYSTEM

## TYPICAL TRAIL MAP SIGN PLACEMENT

Orientation of this sign is to be perpendicular to the trail.

Positioning of the sign should be based on existing landscaping. The diagram shows the preferred location. Keep the sign a minimum of 3-feet from the trail.

Do not place landscape at the base of this sign.

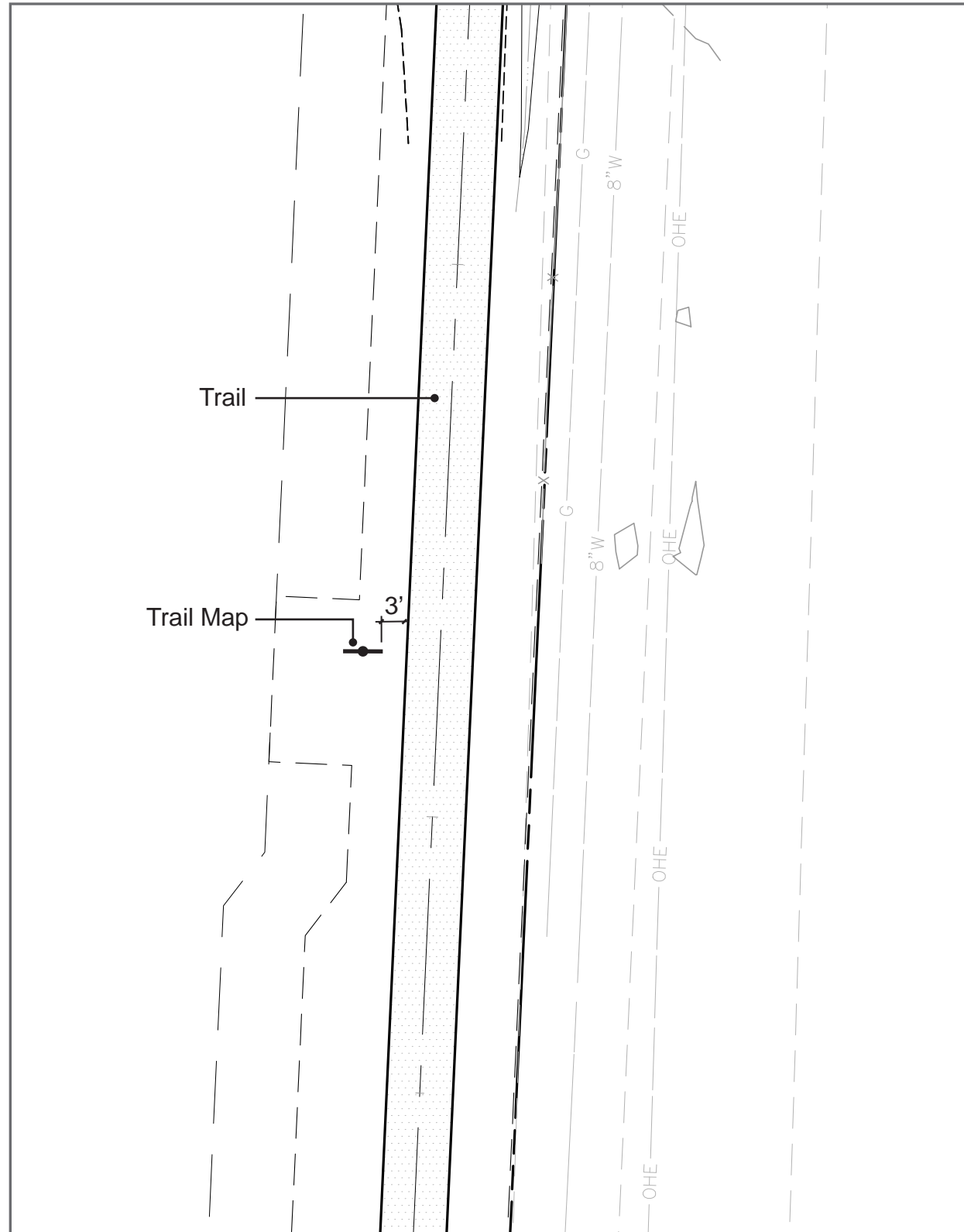





# RAZORBACK GREENWAY SIGN SYSTEM

## COMMUNITY GUIDES

Community guides are part navigation and part encouragement programming. These signs will be placed within communities to direct intended users as well as potential new users to the trail system. These signs will also build awareness of the system by creating a presence for the greenway outside of the system. Co-branding will be placed at the base of this sign as a stand-alone installation. This sign typology may also be attached to posts of existing signage as well as to community light posts.



ELEVATION

# RAZORBACK GREENWAY SIGN SYSTEM

## COMMUNITY GUIDES

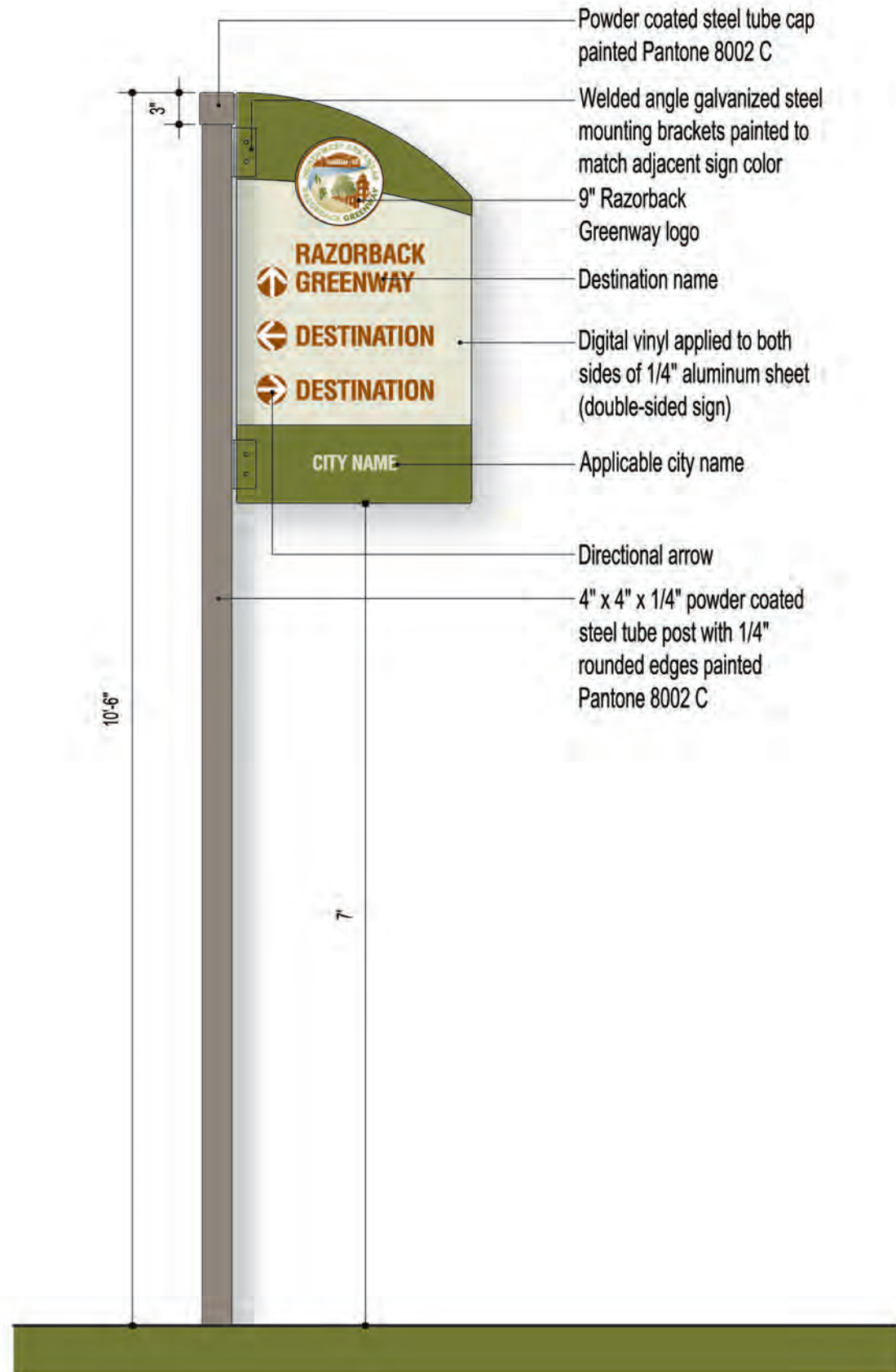

OVERALL DIMENSIONS

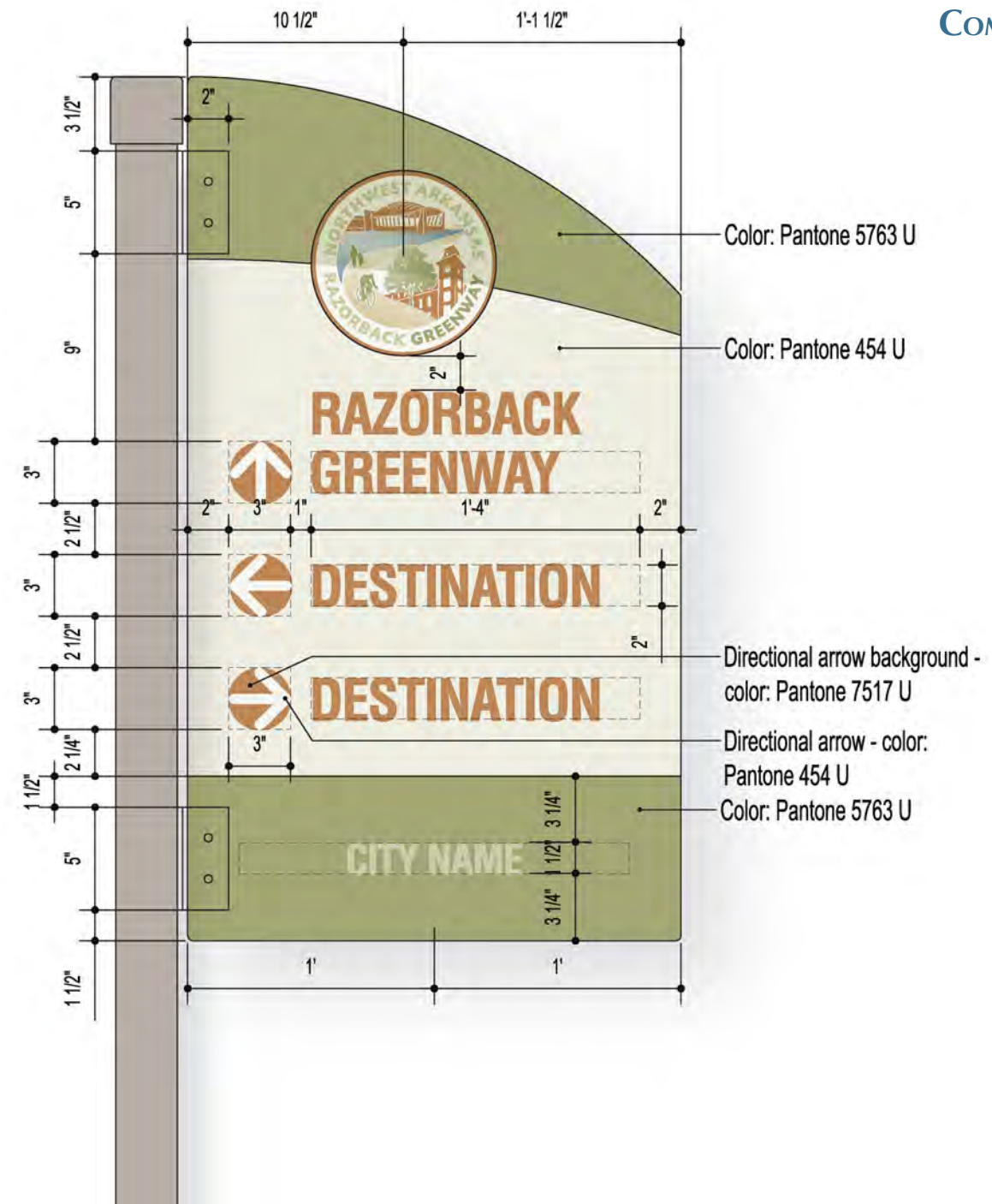

GRAPHIC LAYOUT



# RAZORBACK GREENWAY SIGN SYSTEM

## COMMUNITY GUIDES

### TYPOGRAPHY

#### Destination Text

- Font = Helvetica LT - Bold Condensed
- Align = Left
- Size = 3"
- Tracking = -30
- Color = Pantone 454 U

#### City name

- Font = Helvetica LT - Bold Condensed
- Align = Center
- Size = 1 1/2"
- Tracking = - 25
- Color = Pantone 454 U

### SIGN MOUNT

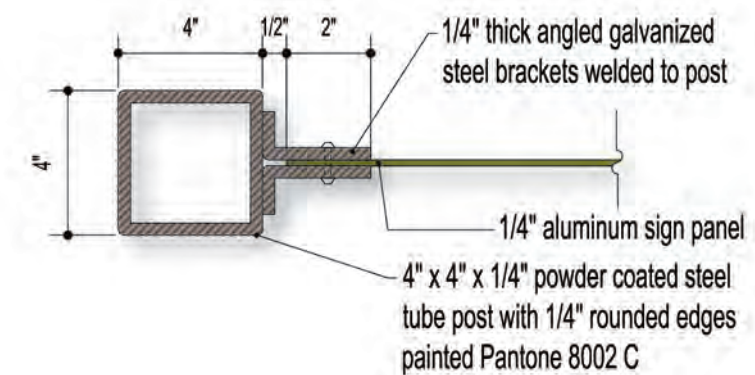

# RAZORBACK GREENWAY SIGN SYSTEM

## TYPICAL COMMUNITY GUIDE PLACEMENT

Community guides are designed to orient the user in circumstances where the trail may intersect with public streets and reconnects at a distant point.

The community guides may be placed on existing features such as utility poles or a freestanding post. The sign should be placed at a height of 7-feet as measured from the ground to the bottom of the sign.

When applied to a freestanding post, the sign must be placed a minimum of 3-feet from the back of curb along the roadway.

Orientation of the sign is to be perpendicular to the direction of travel.

The sign should be placed facing the direction of traffic and pointing toward the nearby trailhead entrance.

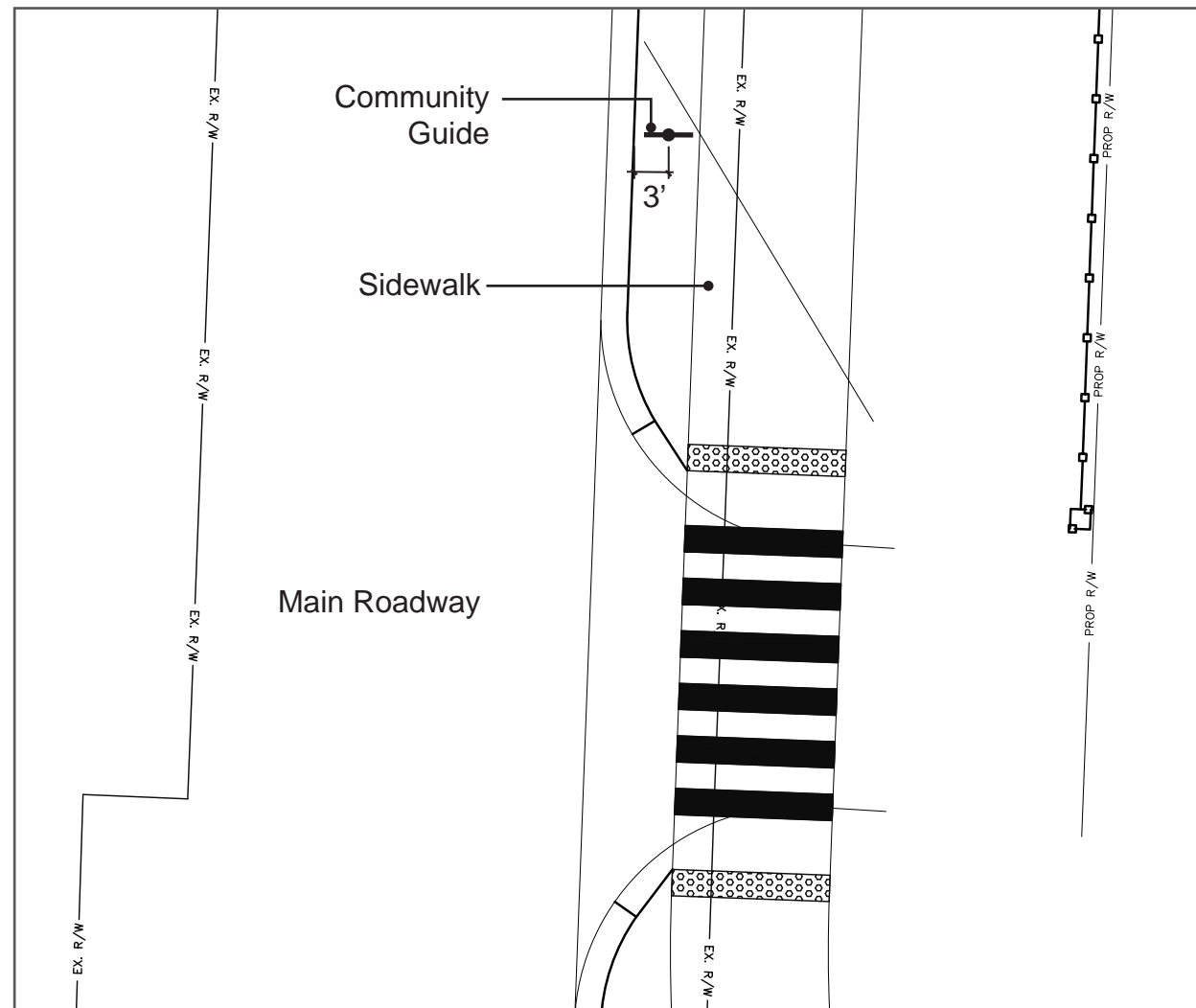



# RAZORBACK GREENWAY SIGN SYSTEM

## DIRECTIONALS

Creating a destination-based greenway system integrates trails into the region's infrastructure. Users can orient themselves within the system based on key destinations including culturally significant landmarks, shopping districts, and other recreational facilities. Co-branding will also occur on the base of this sign type.



# RAZORBACK GREENWAY SIGN SYSTEM

## DIRECTIONALS

### TYPOGRAPHY

**Vertical "RAZORBACK GREENWAY" banner**

- Font = Helvetica LT - Bold Condensed
- Align = Center
- Size = 2"
- Tracking = 100
- Color = Pantone 454 U

**Destination Text**

- Font = Helvetica LT - Bold Condensed
- Align = Left
- Size = 2"
- Tracking = - 25
- Color = Pantone 7517 U

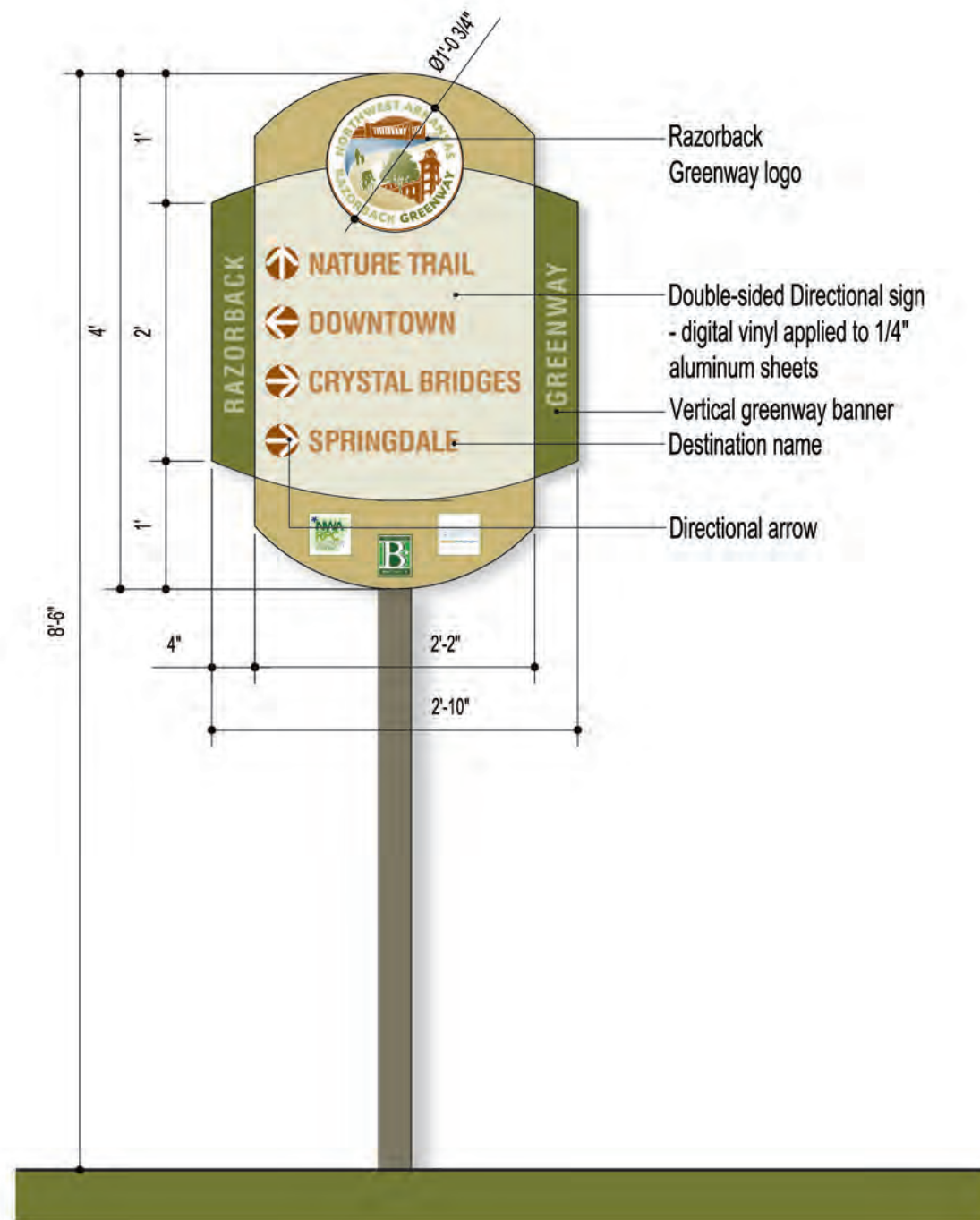

OVERALL DIMENSIONS

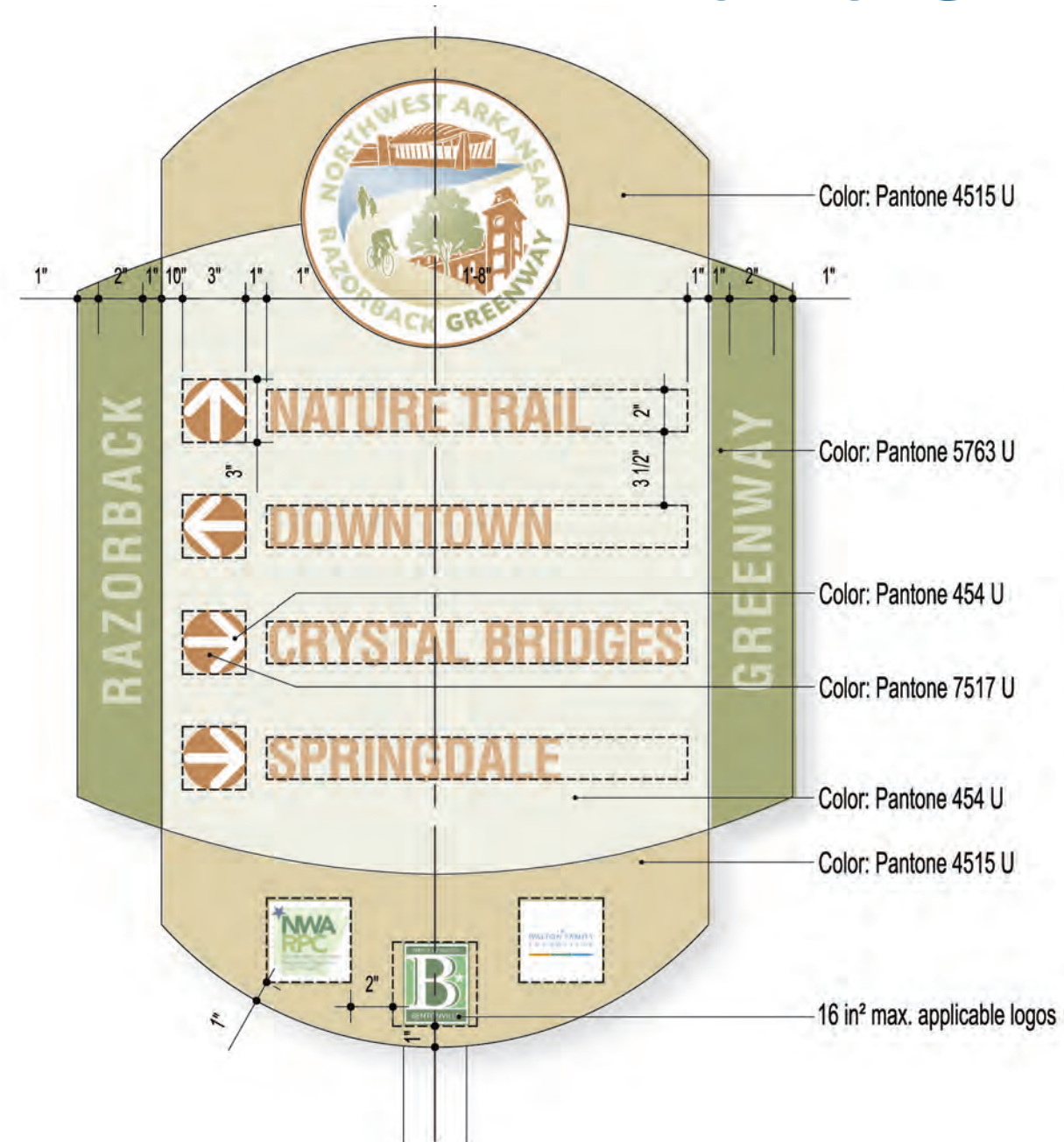

GRAPHIC LAYOUT



# RAZORBACK GREENWAY SIGN SYSTEM

## DIRECTIONALS

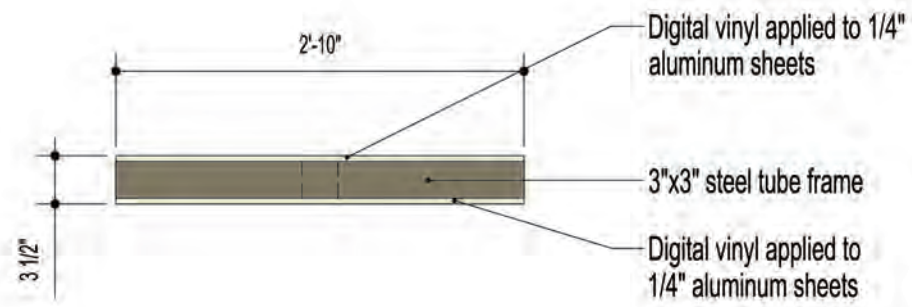

PLAN VIEW

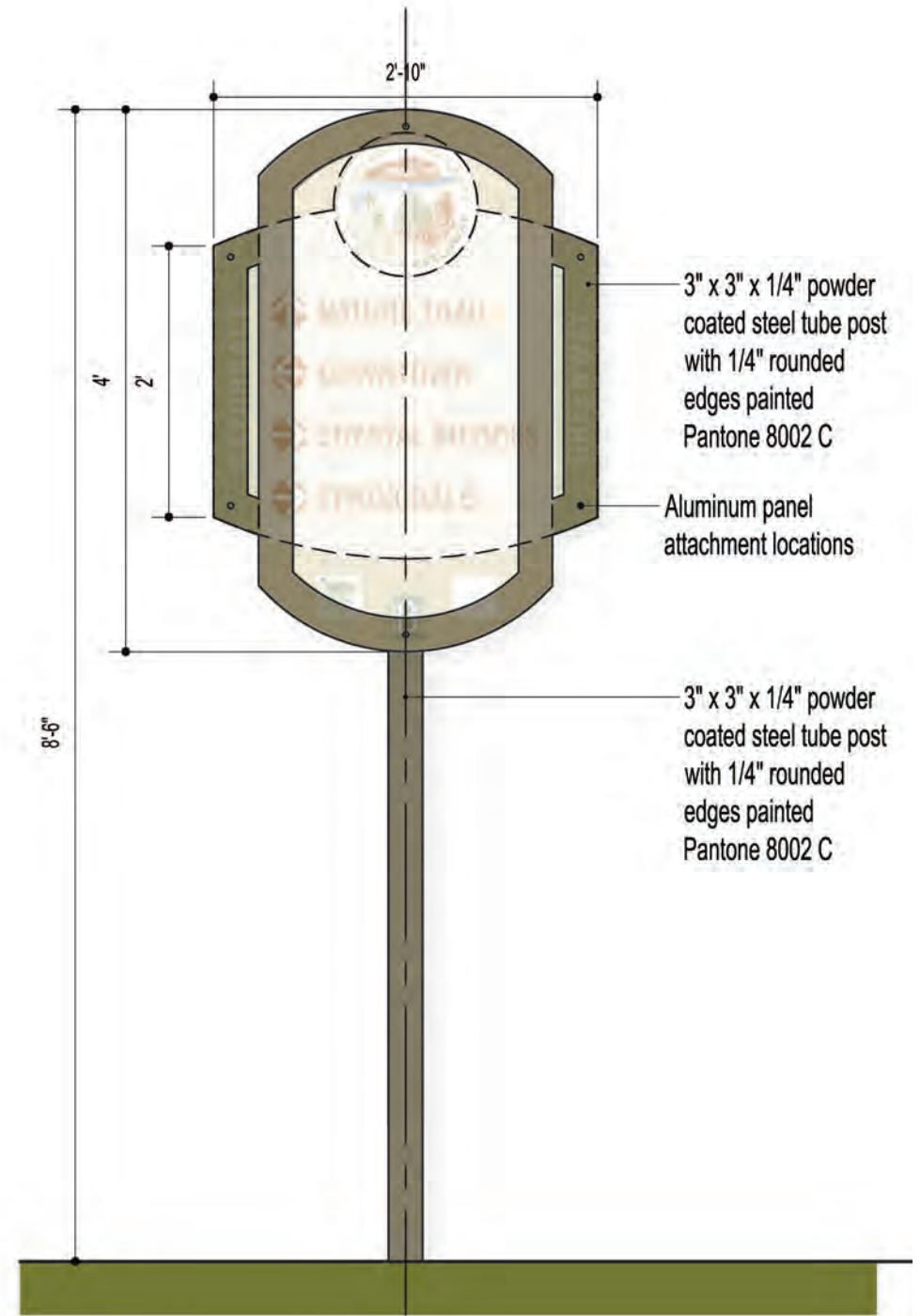

FRAME

# RAZORBACK GREENWAY SIGN SYSTEM

## TYPICAL DIRECTIONAL PLACEMENT

Typically these signs are placed at the intersections of trails and sidewalk facilities. The signs may also be placed where needed to assist visitors.

Orientation of the sign is to be perpendicular to the direction of travel or parallel to the intersecting trail.

Placement should be a minimum of 2-feet from the edge of the sign to the trail. The location should be determined by the site conditions and information that is being conveyed.

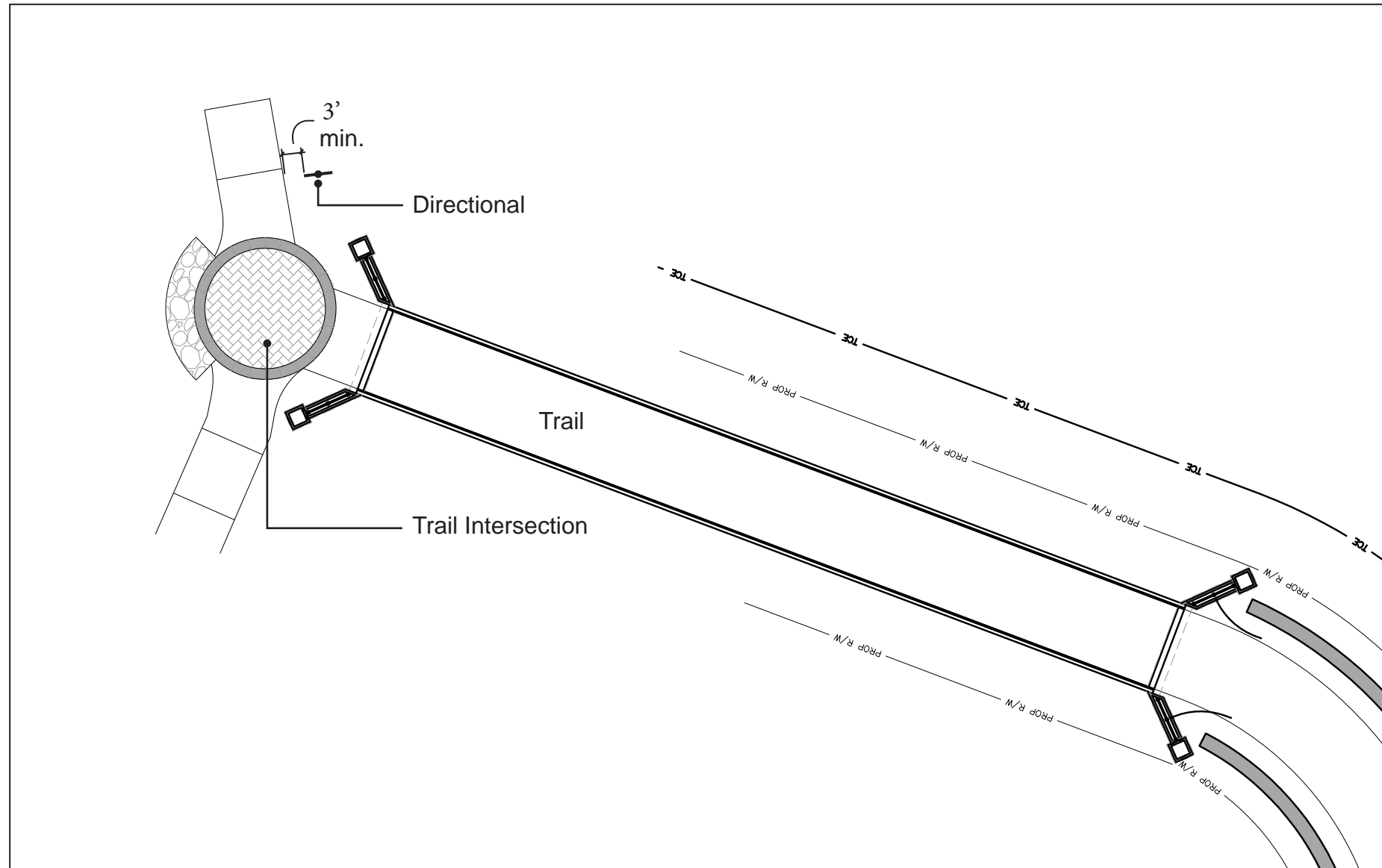





# RAZORBACK GREENWAY SIGN SYSTEM

## MILE MARKERS

Mile markers are key trail elements for fitness users. Tracking distance and improvement over time is expected by health conscious users. This sign typology is also useful for navigation and geographic placement. First responders can quickly find those in need by using mile markers as "addresses" for user location.



ELEVATIONS



# RAZORBACK GREENWAY SIGN SYSTEM

## MILE MARKERS

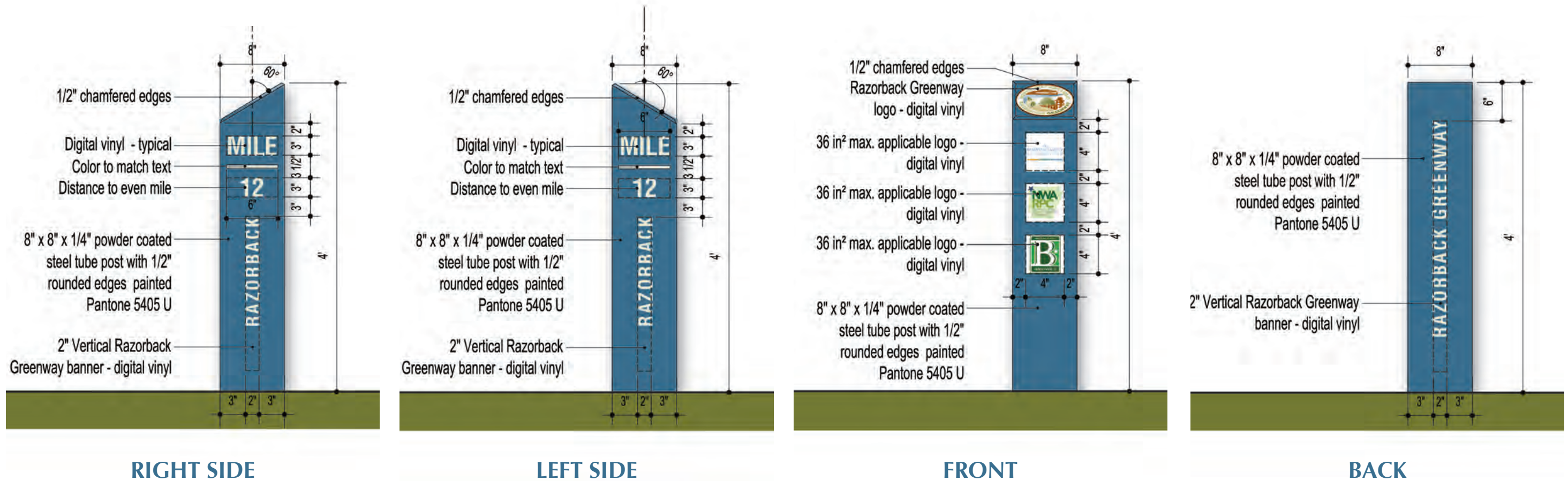

OVERALL DIMENSIONS AND GRAPHIC LAYOUT



# RAZORBACK GREENWAY SIGN SYSTEM

## MILE MARKERS

## TYPOGRAPHY

### Vertical Text ( City Name & Razorback Greenway)

- Font = Helvetica LT - Bold Condensed
- Align = Right
- Size = 2"
- Tracking = 100
- Color = Pantone 454 U

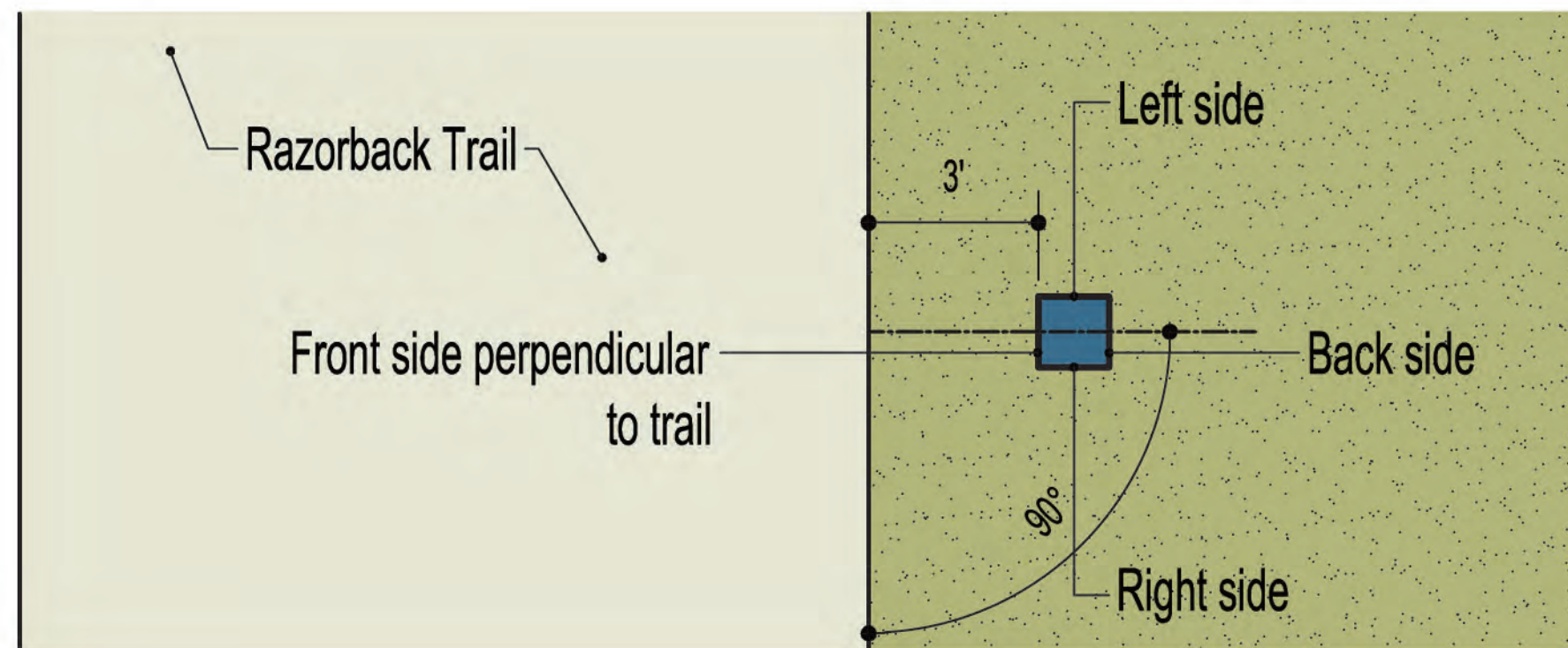

PLAN VIEW

# RAZORBACK GREENWAY SIGN SYSTEM

## TYPICAL MILE MARKER PLACEMENT

Mile markers are to be set at 1/4 mile intervals to provide users with reference points for goal-oriented workouts and wayfinding.

The markers are to be placed on the right hand side of the trail when facing the direction that the distance is increasing.

Orientation of the marker is perpendicular to the trail.

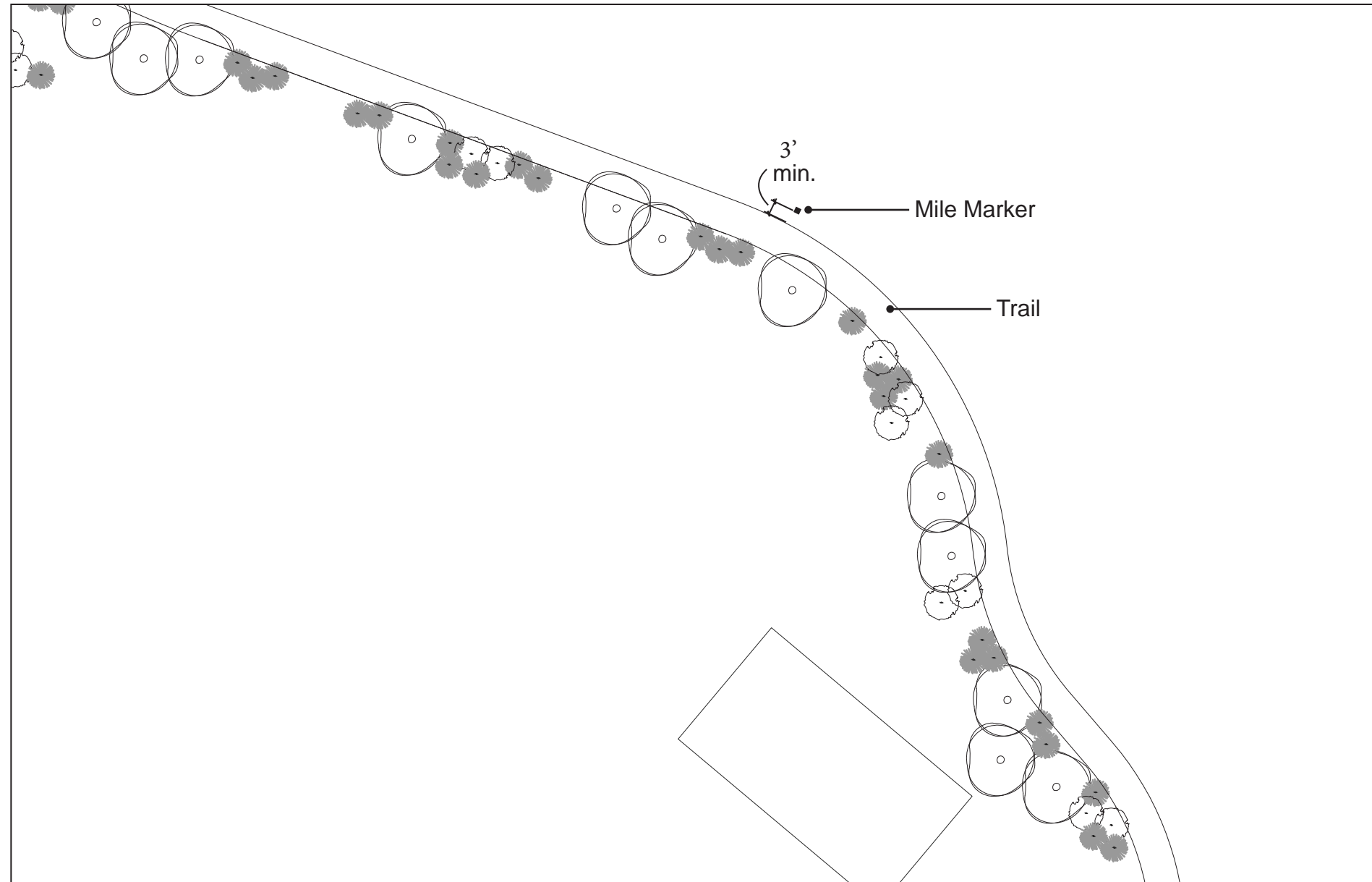



# RAZORBACK GREENWAY SIGN SYSTEM

## WALK/BIKE DISTANCE AND TIME

Providing walk and bike timing and distances helps trail users make decisions to leave the trail to attend to their needs or visit a key destination. This sign type, like the Directional Sign, help orient the user within the system. Walk and Bike timing also serves as an encouragement device to help non-users of the trail (as a transportation system) understand the ease of using the greenway as a transportation method.

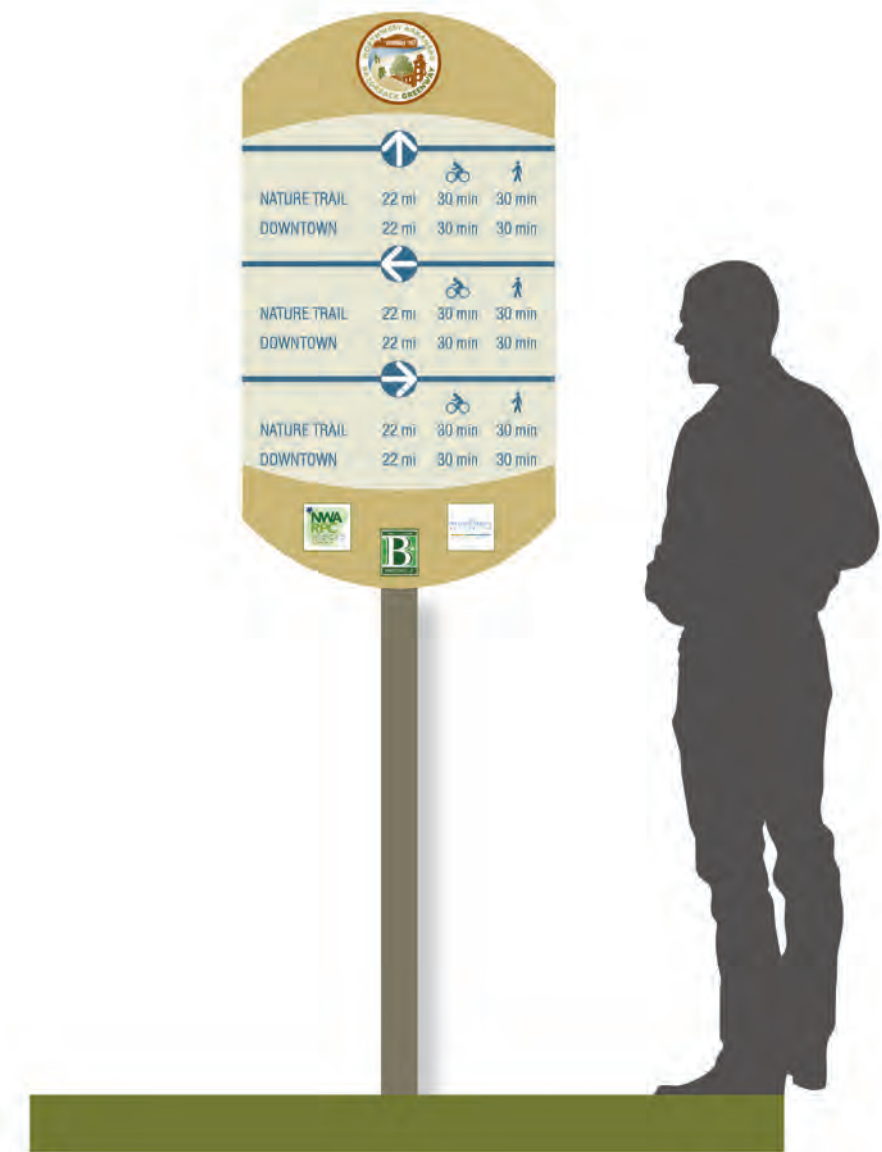

ELEVATION

# RAZORBACK GREENWAY SIGN SYSTEM

## WALK/BIKE DISTANCE AND TIME

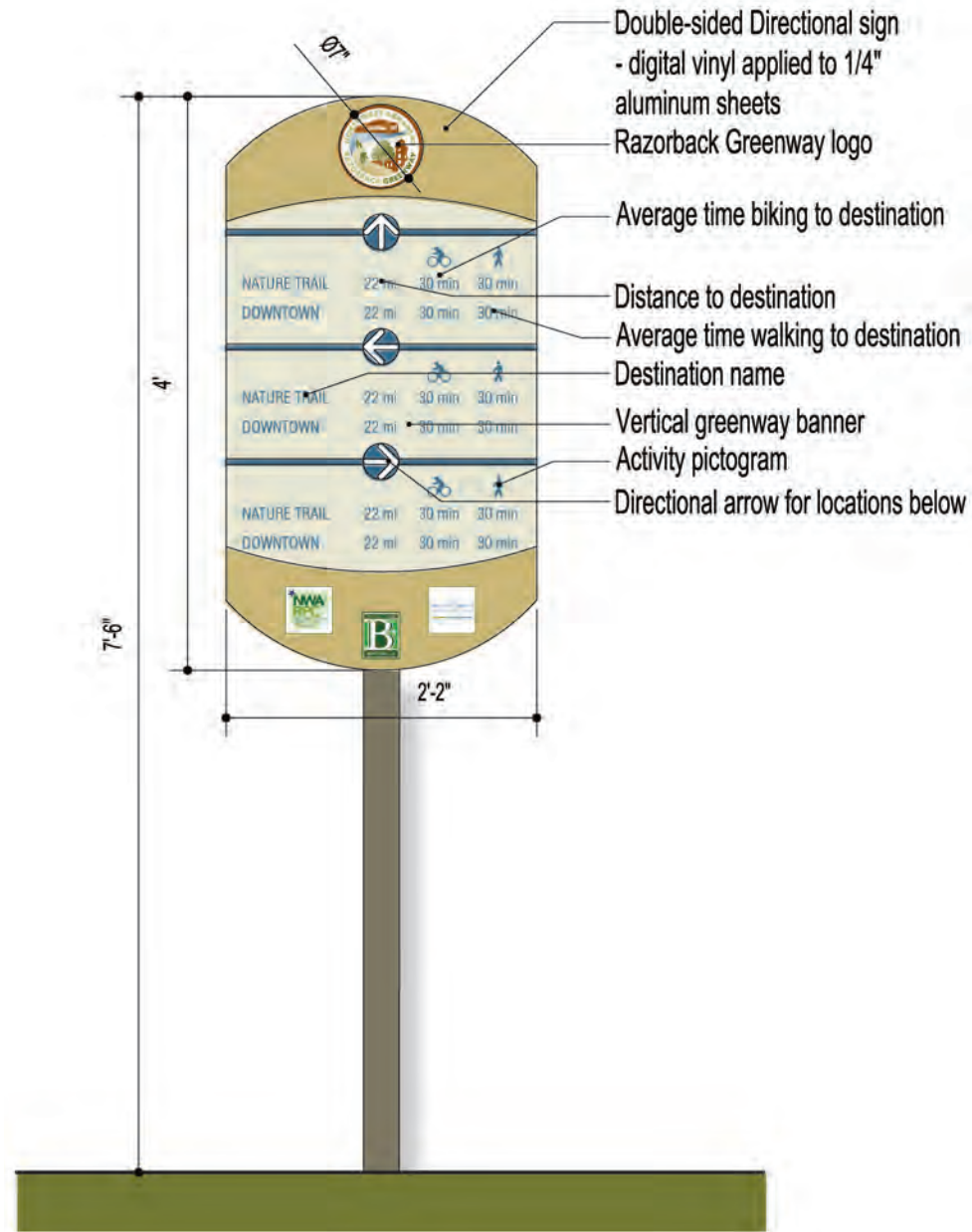

OVERALL DIMENSIONS

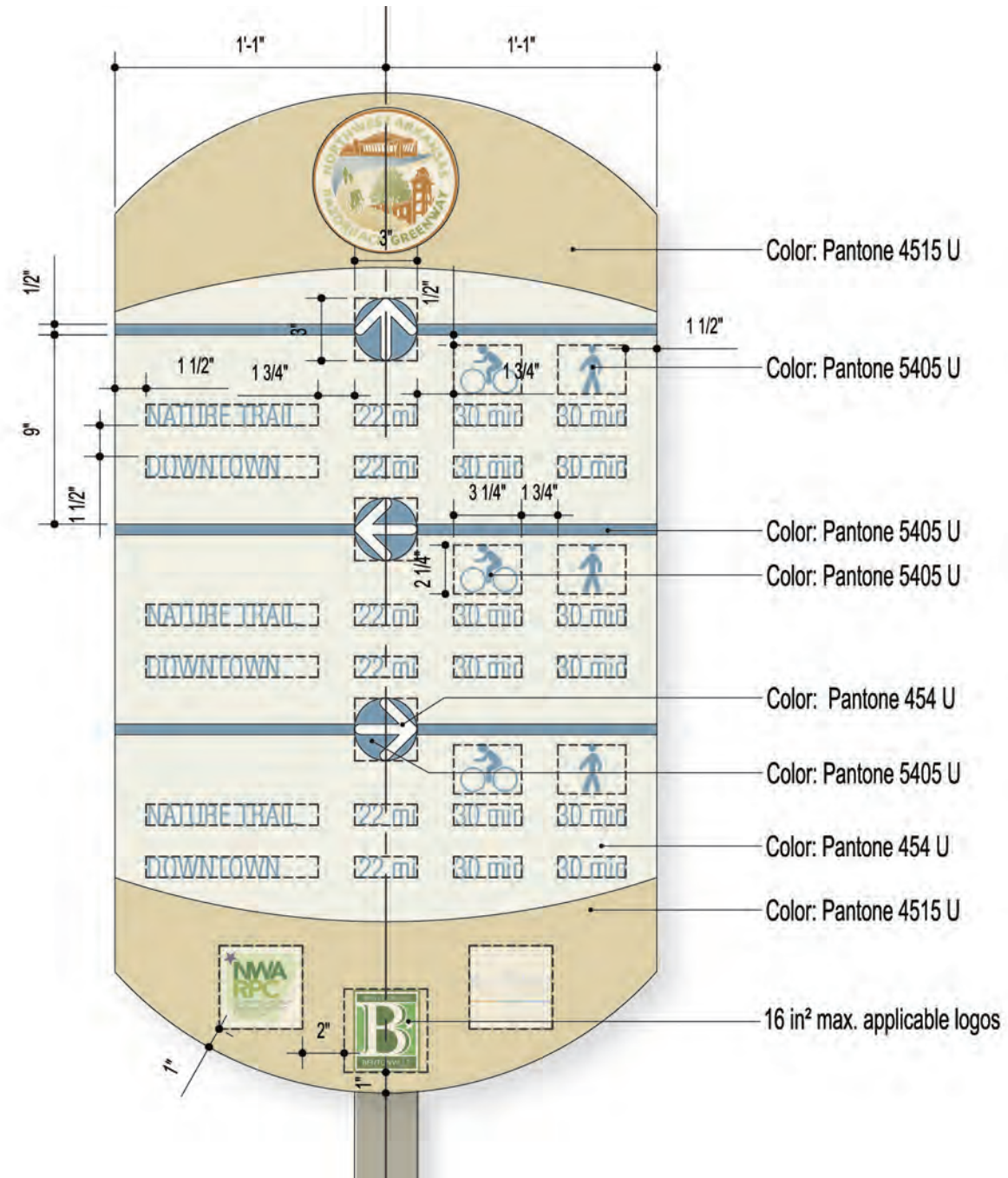

GRAPHIC LAYOUT

## TYPOGRAPHY

### Destination Name Text

- Font = Helvetica LT - Light Condensed
- Align = Left
- Size = 1"
- Tracking = 10
- Color = Pantone 5405 U

### Destination Distances and Travel Times Text

- Font = Helvetica LT - Light Condensed
- Align = Center
- Size = 1"
- Tracking = 10
- Color = Pantone 5405 U



# RAZORBACK GREENWAY SIGN SYSTEM

WALK/BIKE DISTANCE AND TIME

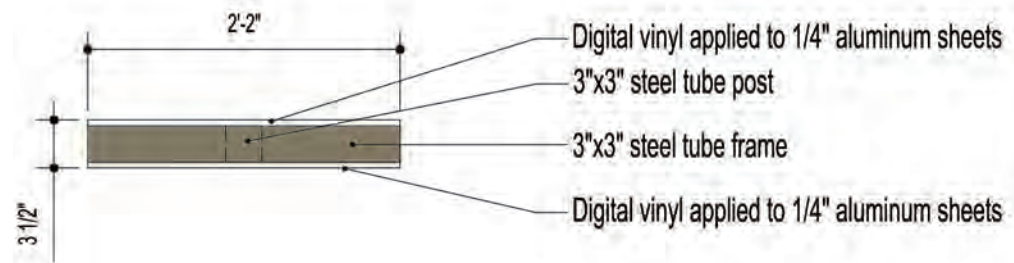

PLAN VIEW

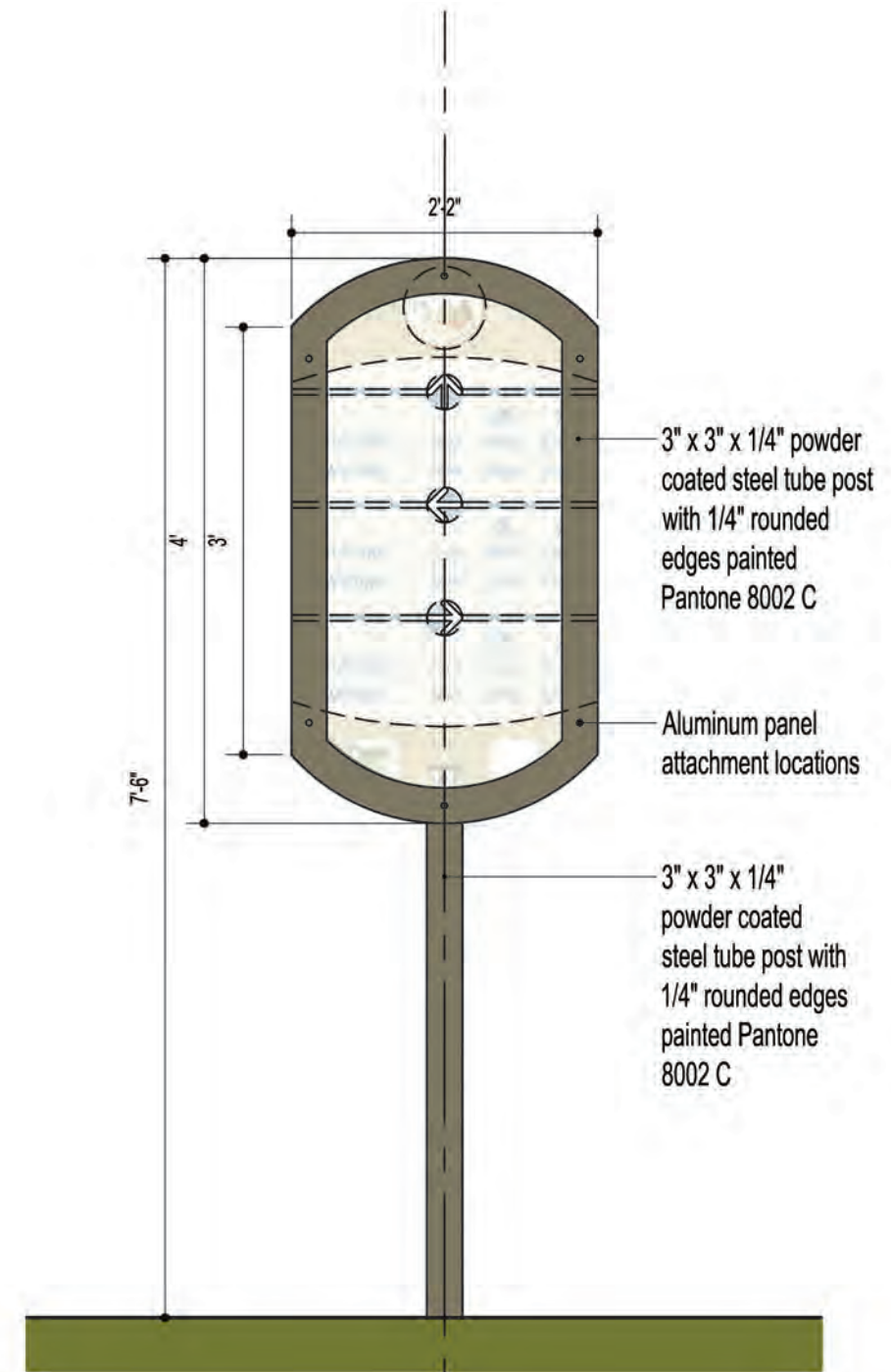

FRAME

# RAZORBACK GREENWAY SIGN SYSTEM

## TYPICAL WALK/BIKE TIMING PLACEMENT

Typically these signs are placed at the intersections of trails and sidewalk facilities. The signs may also be placed where needed to assist visitors.

Orientation of the sign is to be perpendicular to the direction of travel or parallel to the intersecting trail.

Placement should be a minimum of 2-feet from the edge of the sign to the trail. The location should be determined by the site conditions and information that is being conveyed.

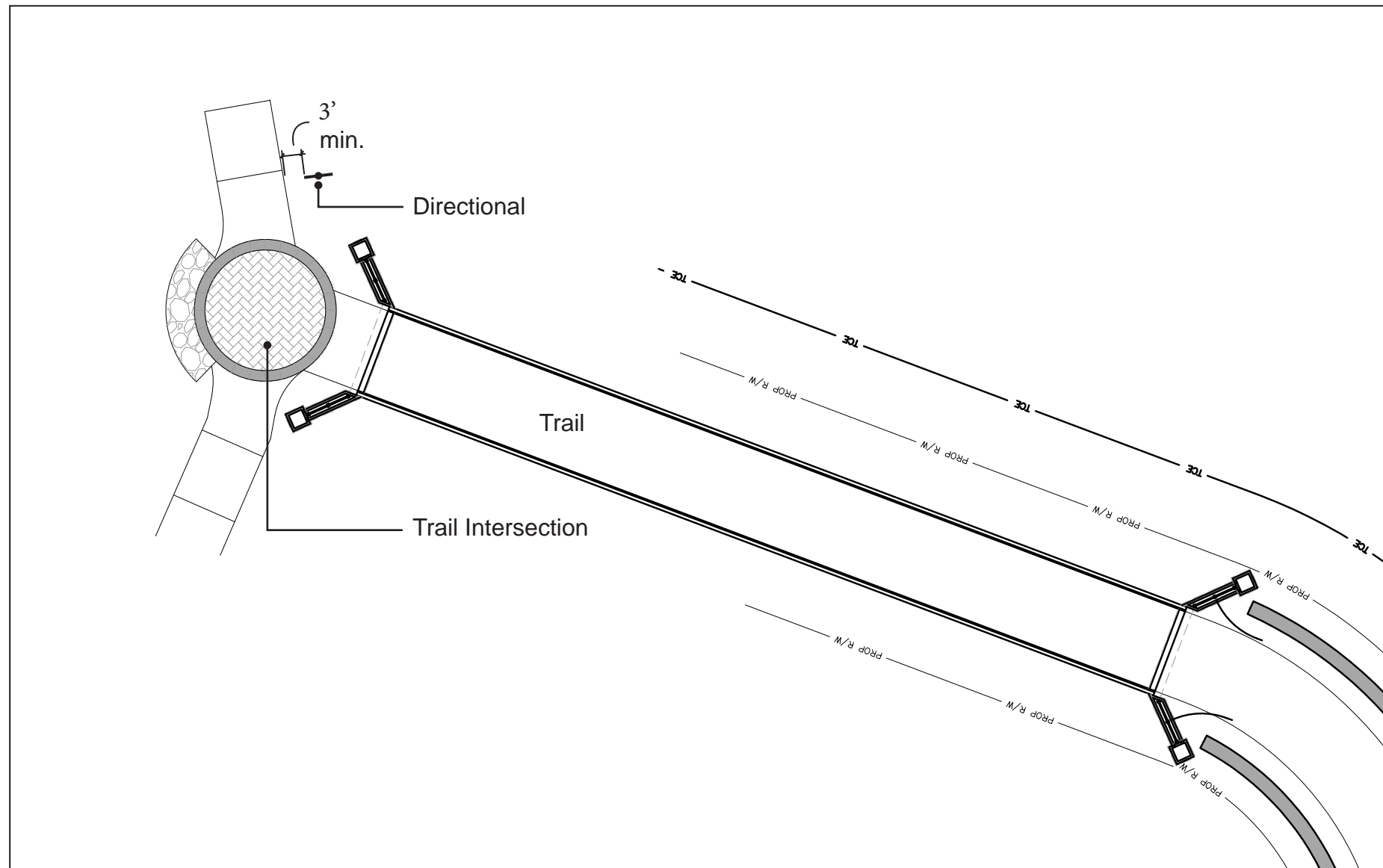





# RAZORBACK GREENWAY SIGN SYSTEM

## CONFIDENCE MARKERS

Confidence Markers are an integral component of any greenway system that crosses roads, intersects with sidewalks, and has poor sightlines to the trail alignment. Placement builds "confidence" that the user is on the correct path and has not strayed from the Razorback Greenway alignment.

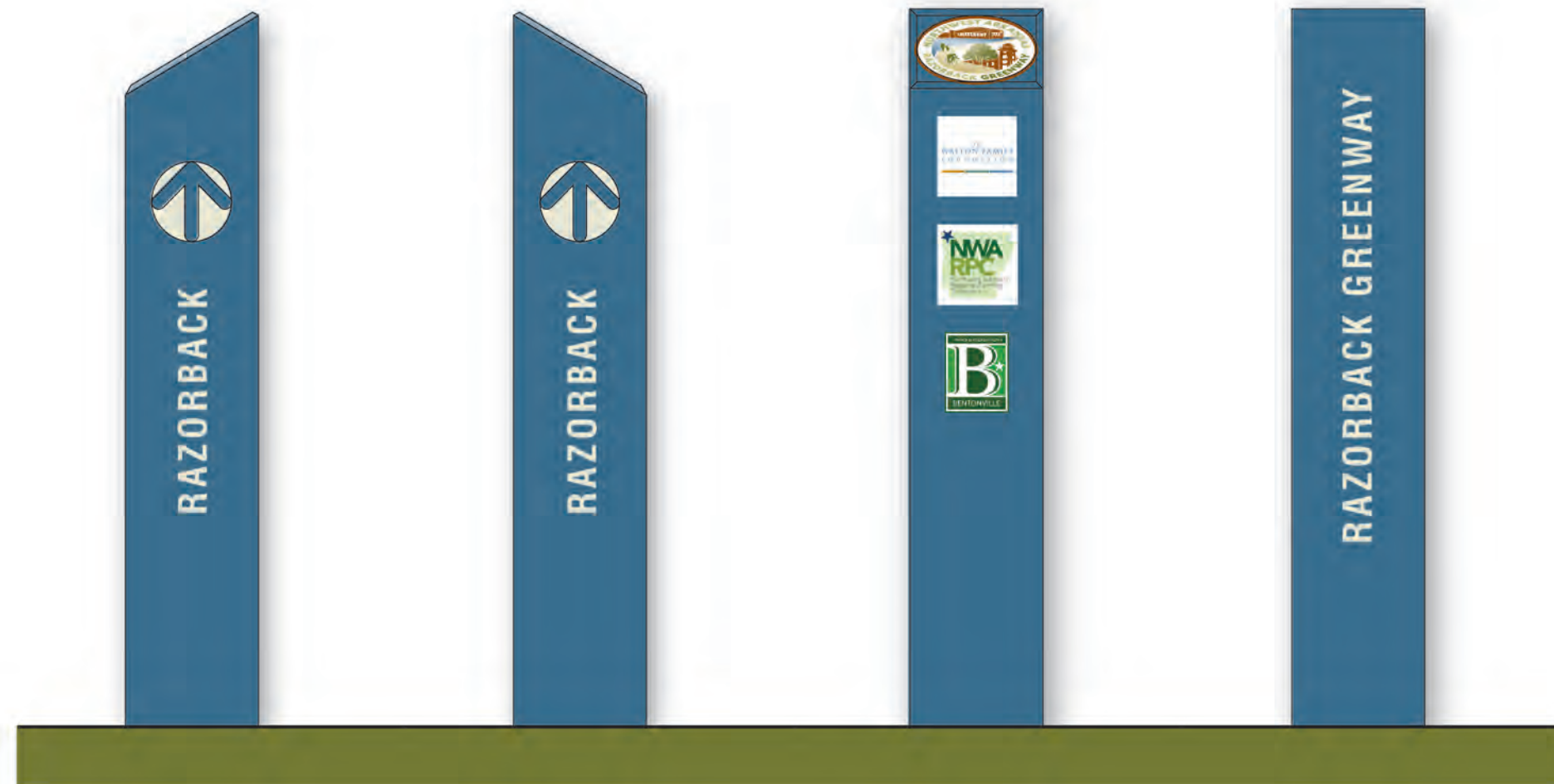

ELEVATIONS

# RAZORBACK GREENWAY SIGN SYSTEM

CONFIDENCE MARKER

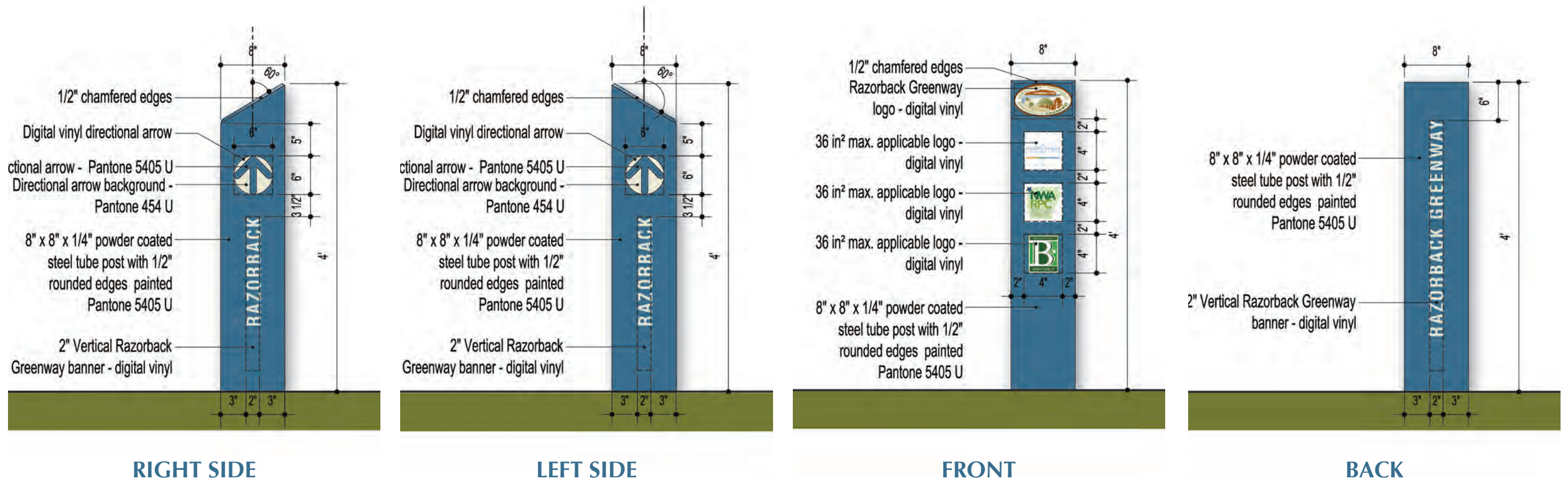

RIGHT SIDE

LEFT SIDE

FRONT

BACK

## OVERALL DIMENSIONS AND GRAPHIC LAYOUT



# RAZORBACK GREENWAY SIGN SYSTEM

## TYPOGRAPHY

### Vertical Text ( City Name & Razorback Greenway)

- Font = Helvetica LT - Bold Condensed
- Align = Right
- Size = 2"
- Tracking = 100
- Color = Pantone 454 U

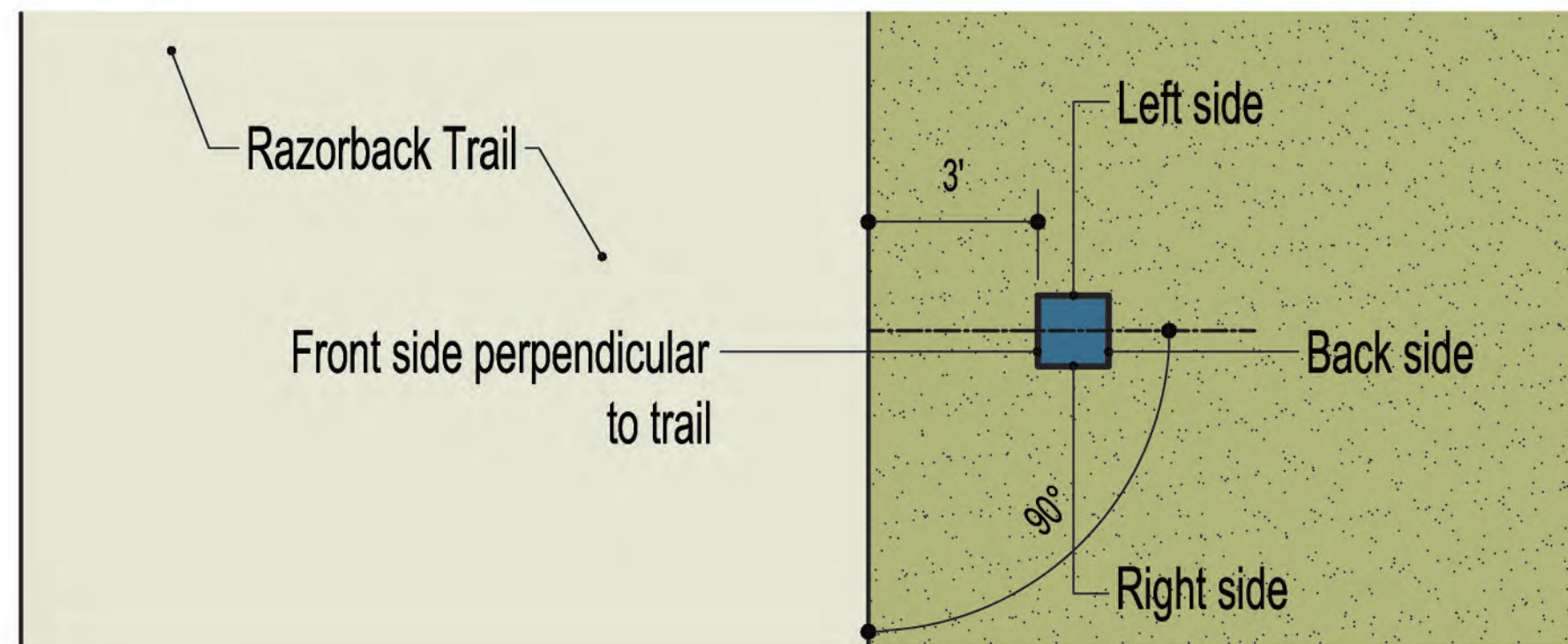

## RAZORBACK GREENWAY SIGN SYSTEM

### TYPICAL CONFIDENCE MARKER PLACEMENT

Trail markers specifically designed to aid navigation in circumstances where the trail may intersect with public streets and reconnects at a distant point.

Orientation of the sign is to be perpendicular to the direction of travel.

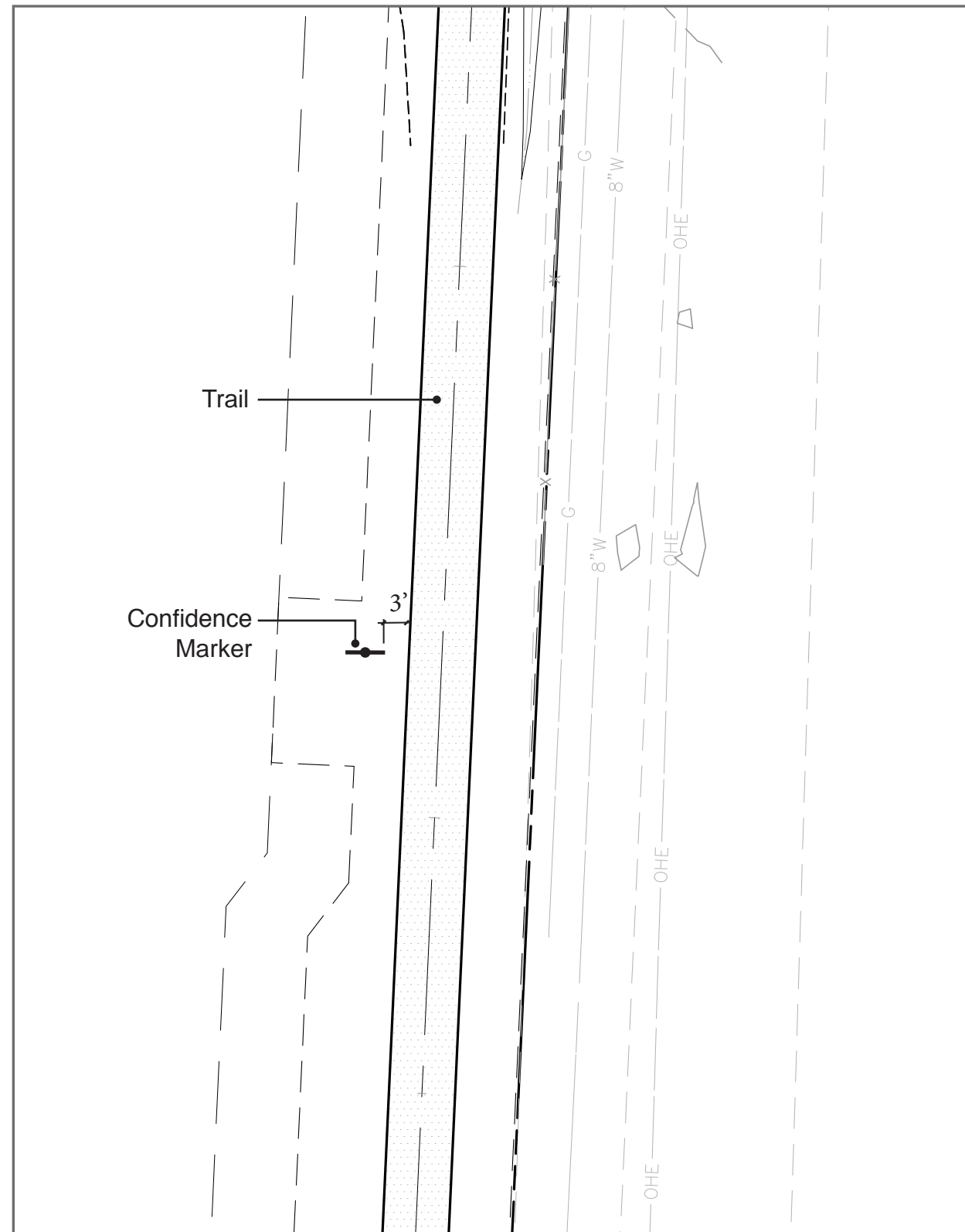



# RAZORBACK GREENWAY SIGN SYSTEM

## INTERPRETIVE DISPLAY

Interpretive Displays contribute to the mission of the greenway as an enhancement of the cultural resources of Northwest Arkansas. Each display will be placed at significant vegetation, topographical, habitat, historical, and other significant landmarks along the trail. Co-branding will be placed in a central location to highlight the community location for the cultural resource.



INTERPRETIVE PANEL



# RAZORBACK GREENWAY SIGN SYSTEM

## INTERPRETIVE DISPLAY

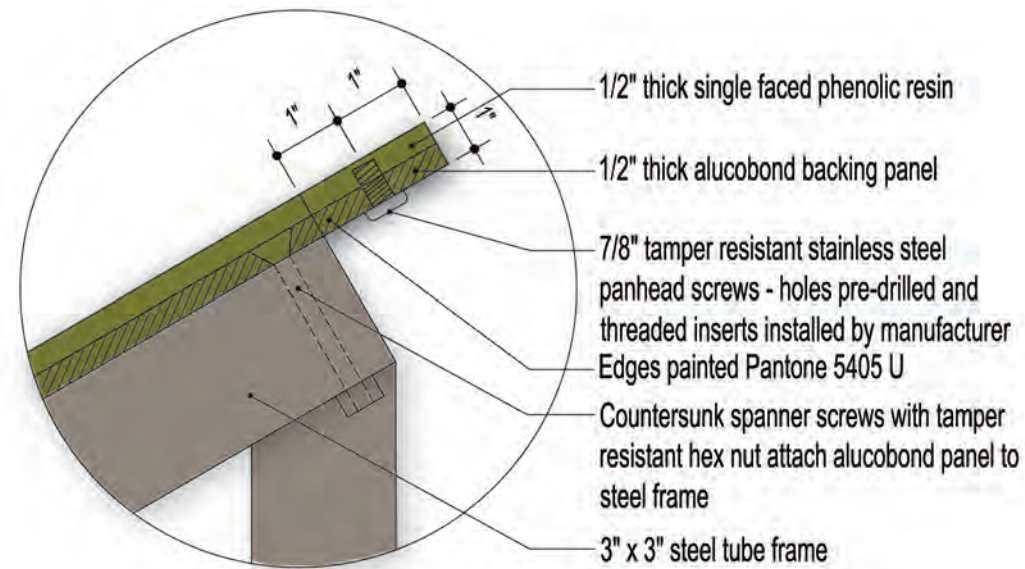

PANEL MOUNT

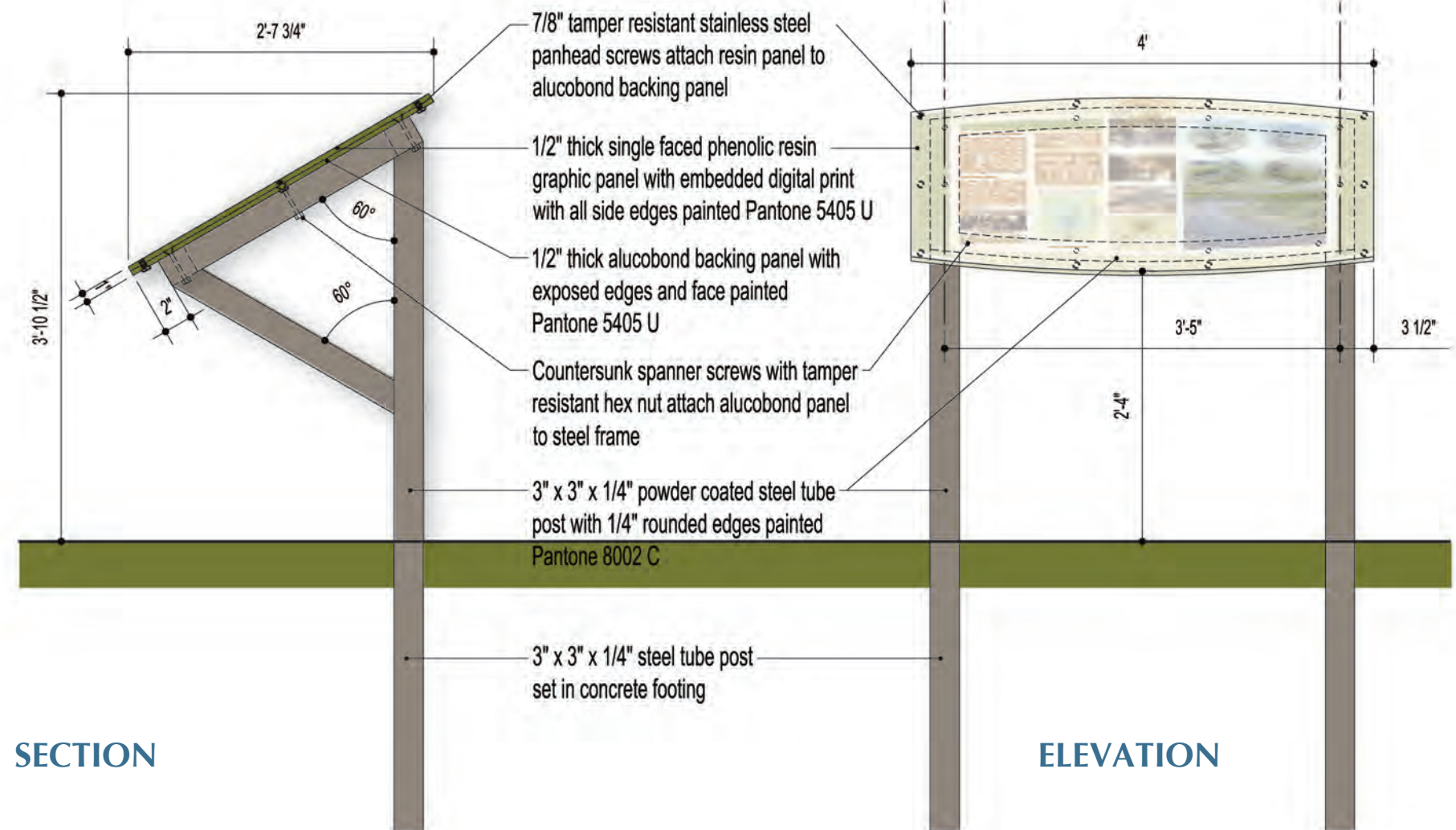



# RAZORBACK GREENWAY SIGN SYSTEM

## INTERPRETIVE DISPLAY

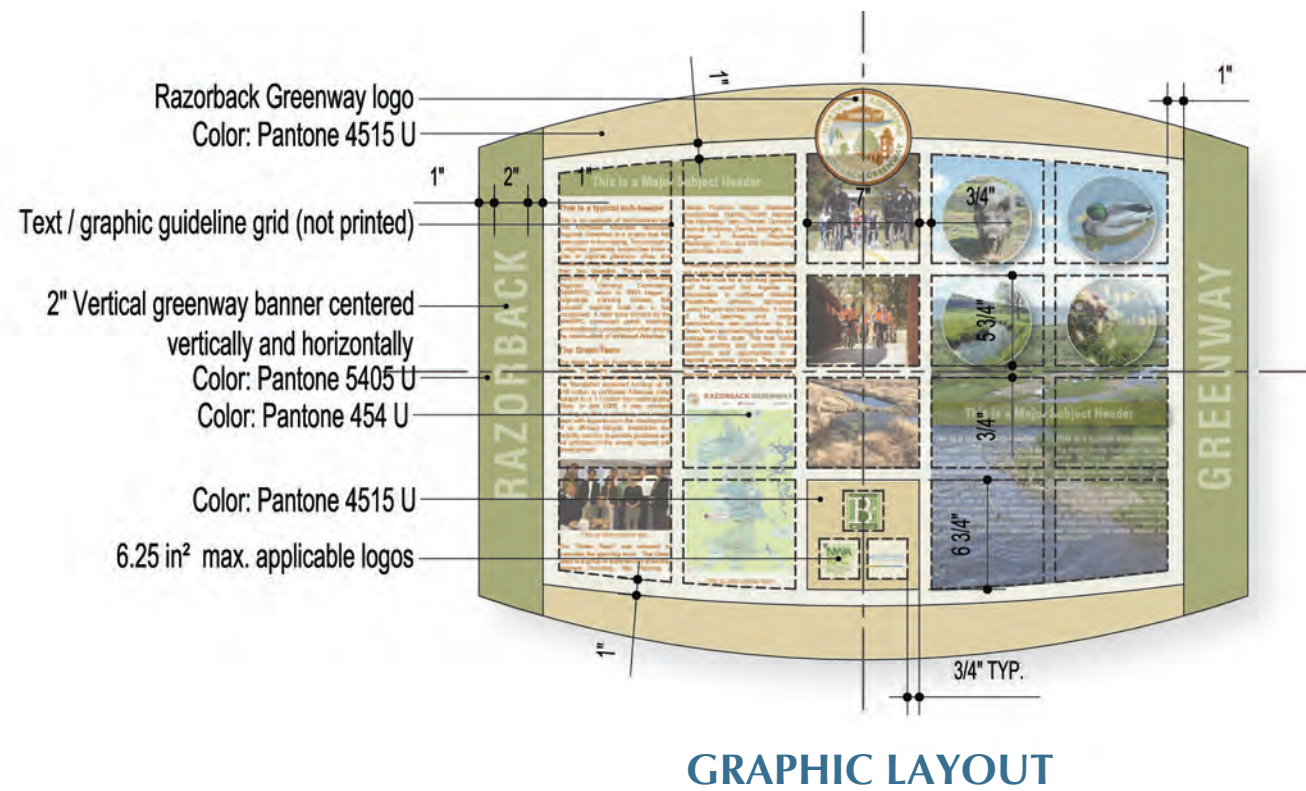

## TYPOGRAPHY

### Vertical "RAZORBACK GREENWAY" banner

- Font = Helvetica LT - Bold Condensed
- Align = Center
- Size = 2"
- Tracking = 100
- Color = Pantone 454 U

### Major Subject Header Text

- Font = Helvetica LT - Bold Condensed
- Align = Center
- Size = 1"
- Color = Pantone 7517 U

### Sub-Header Text

- Font = Helvetica LT - Bold Condensed
- Align = Left
- Size = 3/4"
- Color = Pantone 7517 U

### Informational / Body Text

- Font = Helvetica LT - Light
- Align = Fully justified
- Size = 5/8"
- Color = Pantone 7517 U

# RAZORBACK GREENWAY SIGN SYSTEM

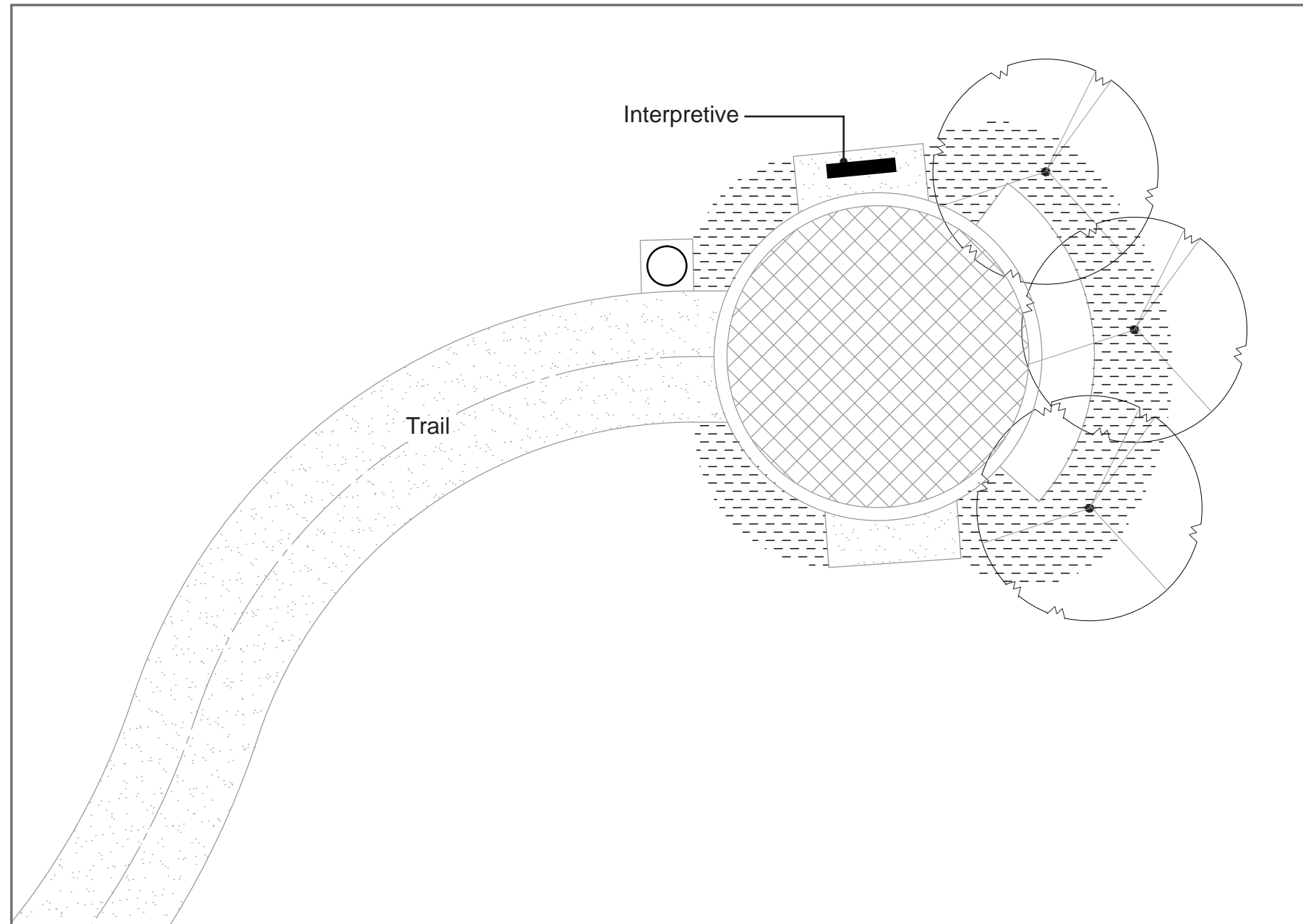

## TYPICAL INTERPRETIVE DISPLAY PLACEMENT

Interpretive signs are to provide educational information to visitors.

The placement of the sign is dependent upon the site and information that is to be portrayed.

Orientation of the sign whenever possible should be parallel to the view of the subject.

It is also recommended that the sign be placed out of the main path of circulation.

Do not place landscape at the base of this sign.





# SYSTEM-WIDE SIGN LOCATION MASTER PLAN

## OVERVIEW

The Razorback Regional Greenway will have a complete package of branded signs throughout all communities from Walker Park in Fayetteville to Bella Vista in Bentonville. Each quarter mile will be marked for fitness tracking and to aid in navigation, safety, and meeting locations. The map below shows the entire Razorback Greenway.



# SYSTEM-WIDE SIGN LOCATION MASTER PLAN

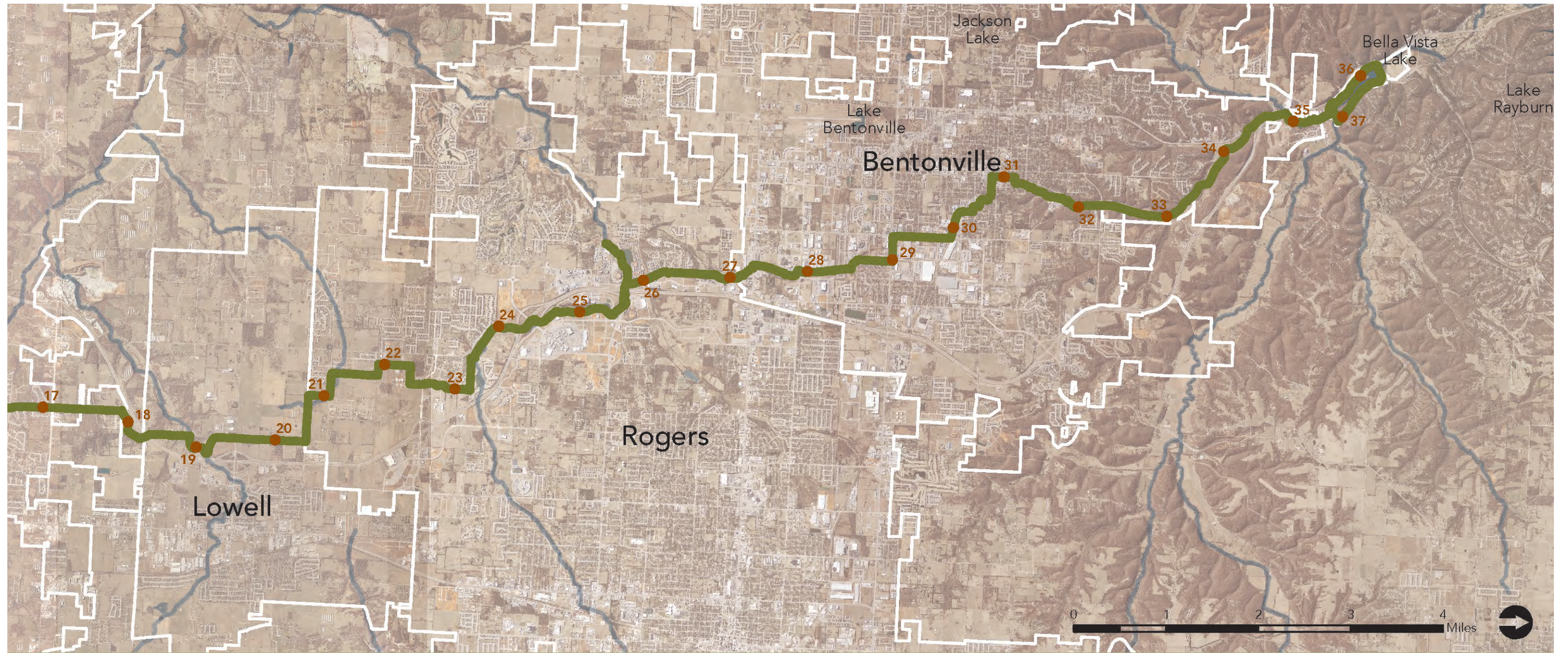



# SYSTEM-WIDE SIGN LOCATION MASTER PLAN: FAYETTEVILLE

## OVERVIEW

In addition to the sign typologies indicated on the map to the right, mile markers will be placed every quarter mile along the trail. As new sections of adjoining trails are constructed, additional signage may be required for clarity and navigation. Development of new commercial centers, unveiled historic landmarks, schools, and culturally significant sites should be monitored and deemed appropriate for addition to the greenway system signage installation.



**A**  
INFORMATION  
KIOSK

**B**  
DIRECTIONAL

**C**  
MAP

**D**  
WALK/BIKE  
DESTINATION

**E**  
INTERPRETIVE  
SIGN



# SYSTEM-WIDE SIGN LOCATION MASTER PLAN: FAYETTEVILLE

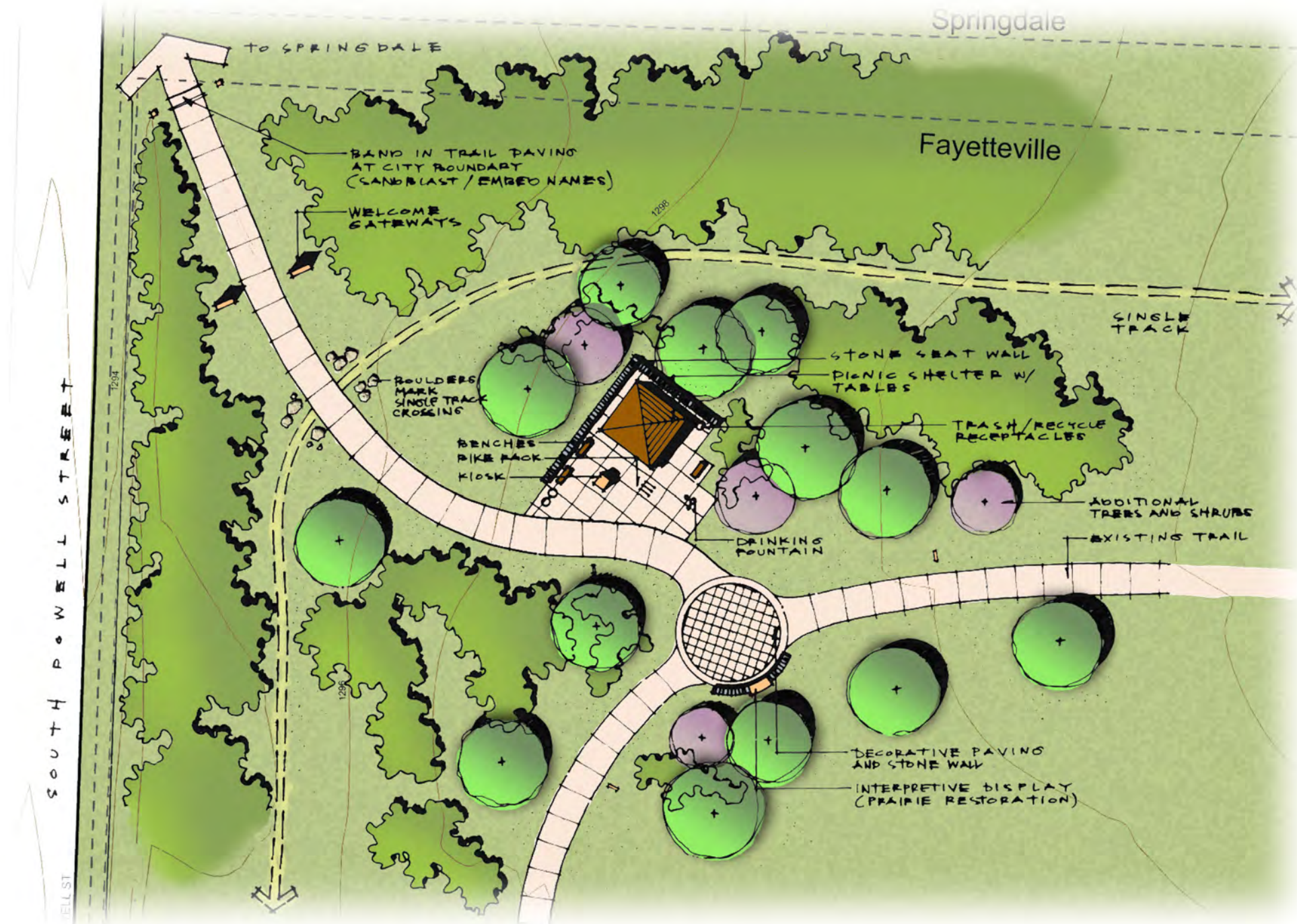

# SYSTEM-WIDE SIGN LOCATION MASTER PLAN: FAYETTEVILLE

*This Page Intentionally Left Blank*



# SYSTEM-WIDE SIGN LOCATION MASTER PLAN: SPRINGDALE

## OVERVIEW

In addition to the sign typologies indicated on the map to the right, mile markers will be placed every quarter mile along the trail. As new sections of adjoining trails are constructed, additional signage may be required for clarity and navigation. Development of new commercial centers, unveiled historic landmarks, schools, and culturally significant sites should be monitored and deemed appropriate for addition to the greenway system signage installation.



**A**  
INFORMATION  
KIOSK

**B**  
DIRECTIONAL

**C**  
MAP

**D**  
WALK/BIKE  
DESTINATION

**E**  
INTERPRETIVE  
SIGN

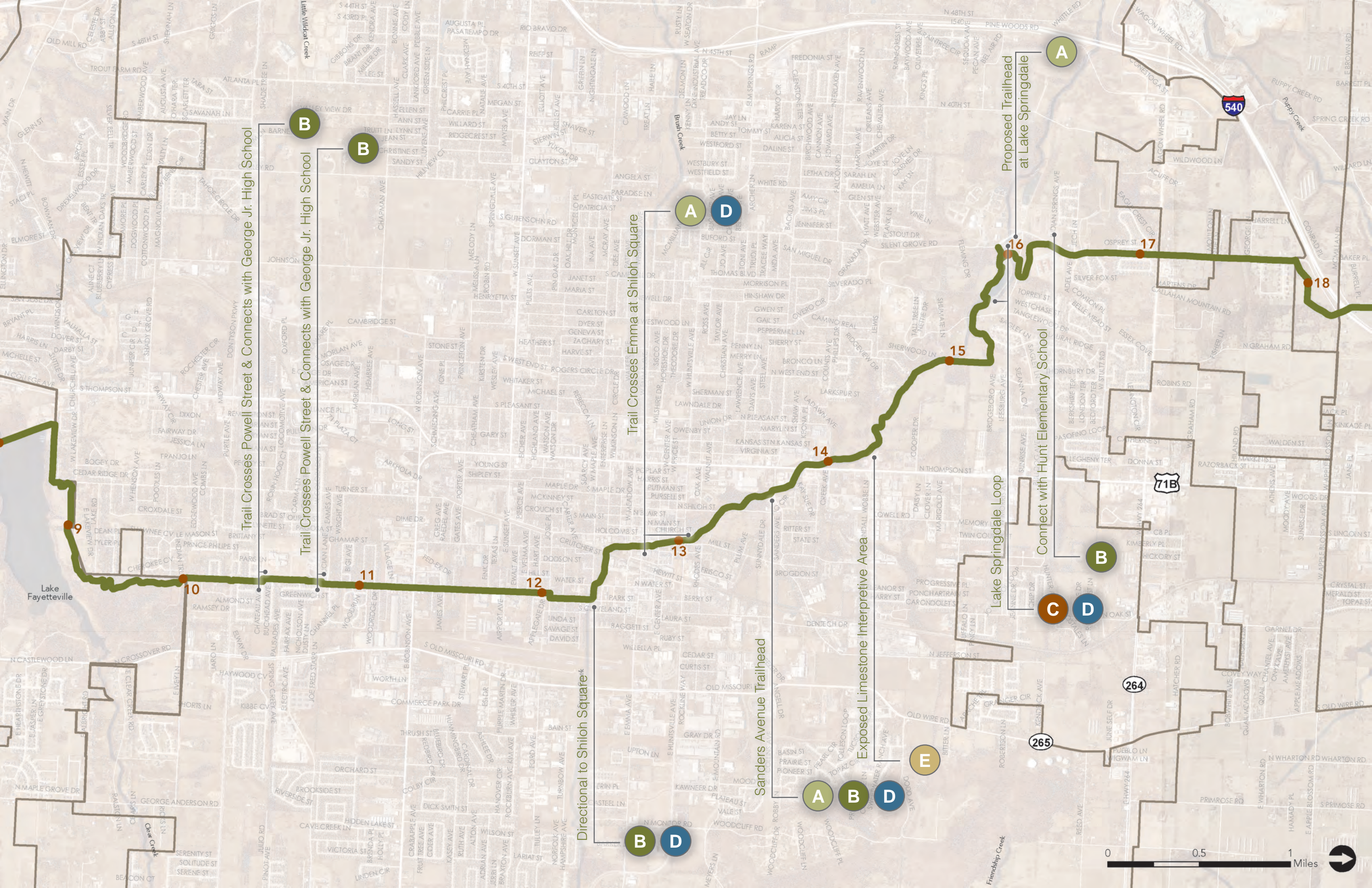

Trail Crosses Powell Street & Connects with George Jr. High School

Trail Crosses Powell Street & Connects with George Jr. High School

Trail Crosses Emma at Shiloh Square

Sanders Avenue Trailhead

Exposed Limestone Interpretive Area

Lake Springdale Loop

Connect with Hunt Elementary School

Proposed Trailhead at Lake Springdale

B

B

A

D

A

C

B

D

E

A

B

D

B

D

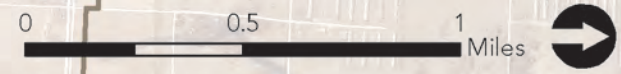

540

71B

264

265

Miles



# SYSTEM-WIDE SIGN LOCATION MASTER PLAN: SPRINGDALE

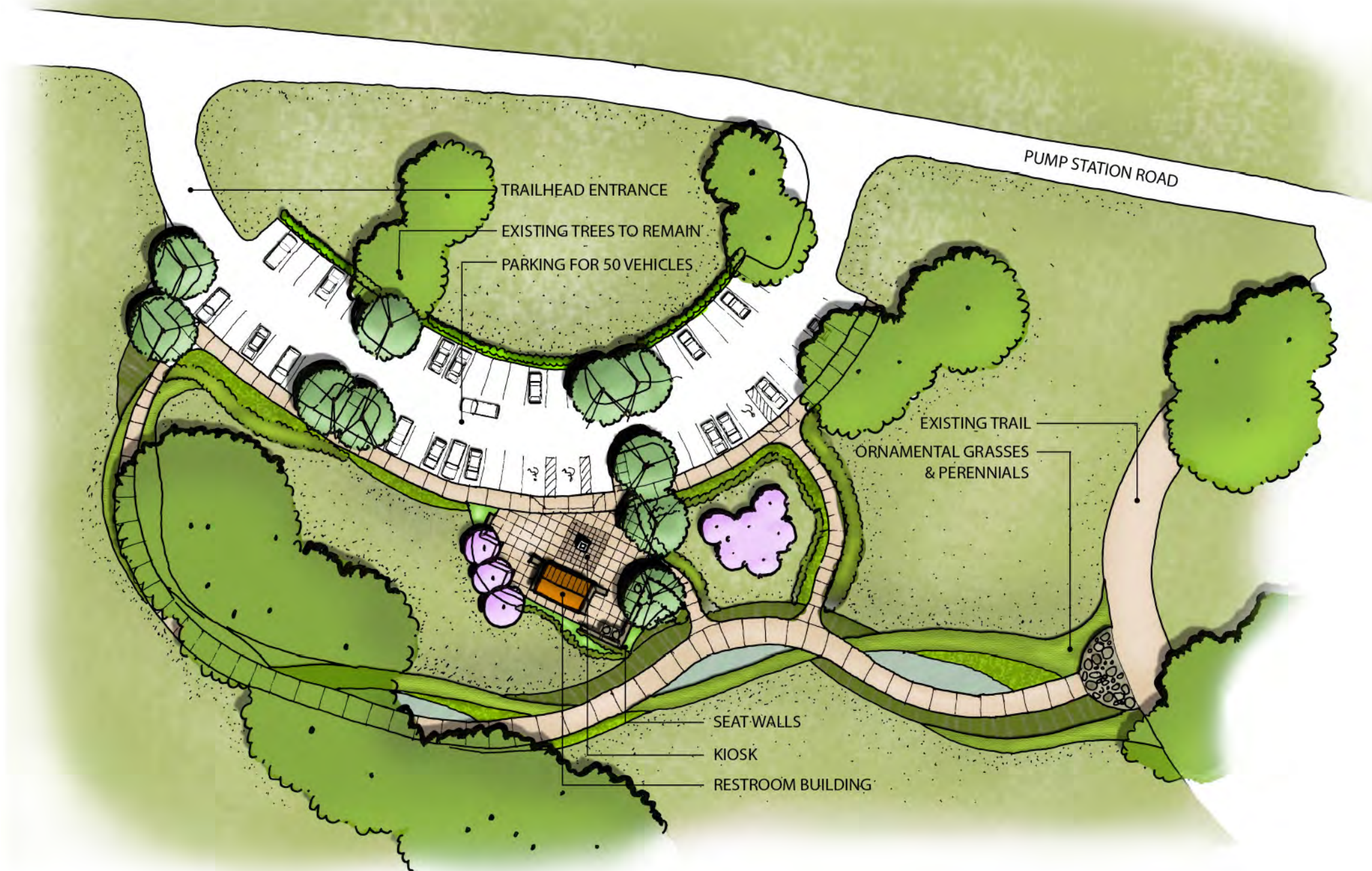

# SYSTEM-WIDE SIGN LOCATION MASTER PLAN: SPRINGDALE

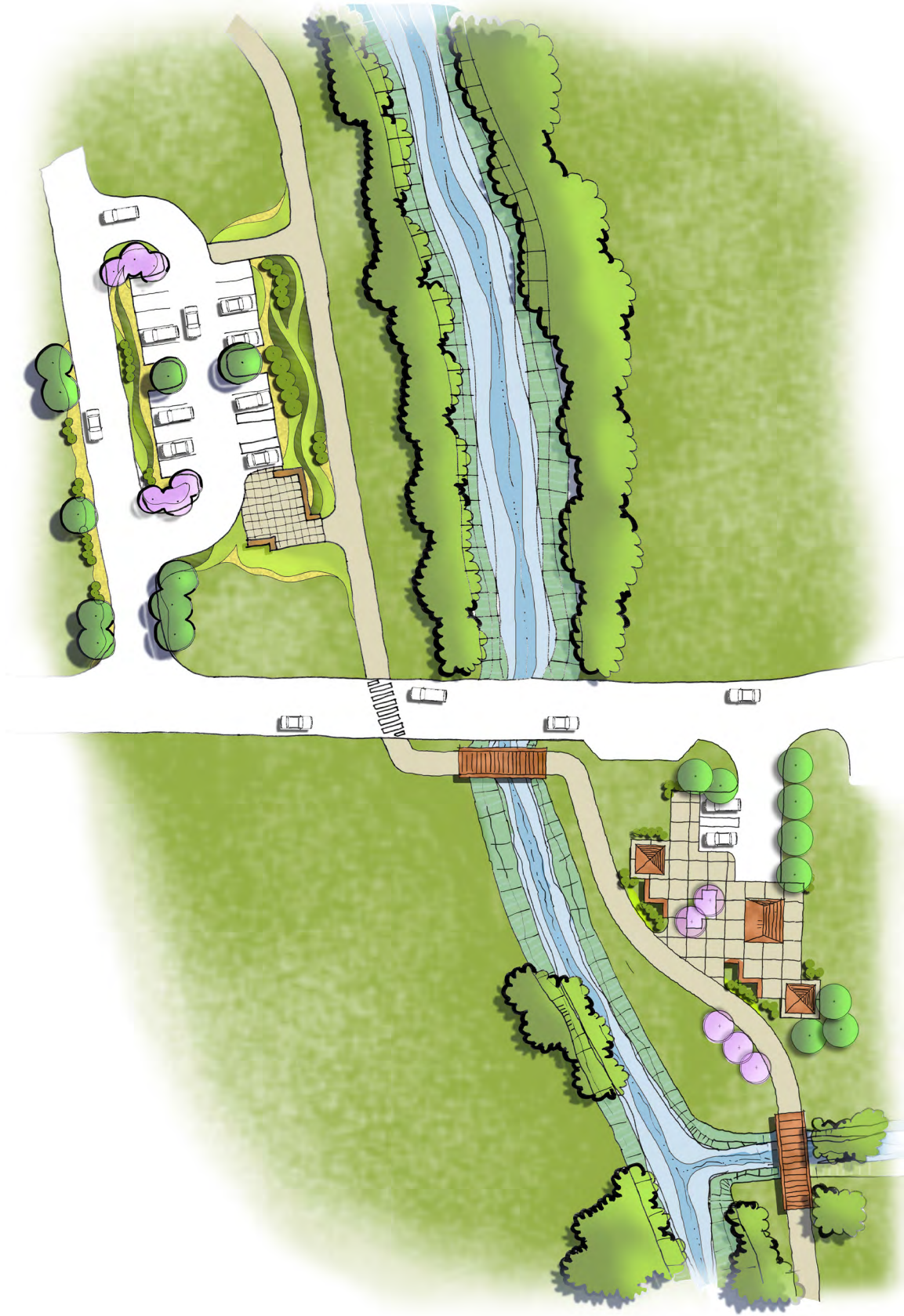



# SYSTEM-WIDE SIGN LOCATION MASTER PLAN: LOWELL

## OVERVIEW

In addition to the sign typologies indicated on the map to the right, mile markers will be placed every quarter mile along the trail. As new sections of adjoining trails are constructed, additional signage may be required for clarity and navigation. Development of new commercial centers, unveiled historic landmarks, schools, and culturally significant sites should be monitored and deemed appropriate for addition to the greenway system signage installation.



**A**  
INFORMATION  
KIOSK

**B**  
DIRECTIONAL

**C**  
MAP

**D**  
WALK/BIKE  
DESTINATION

**E**  
INTERPRETIVE  
SIGN

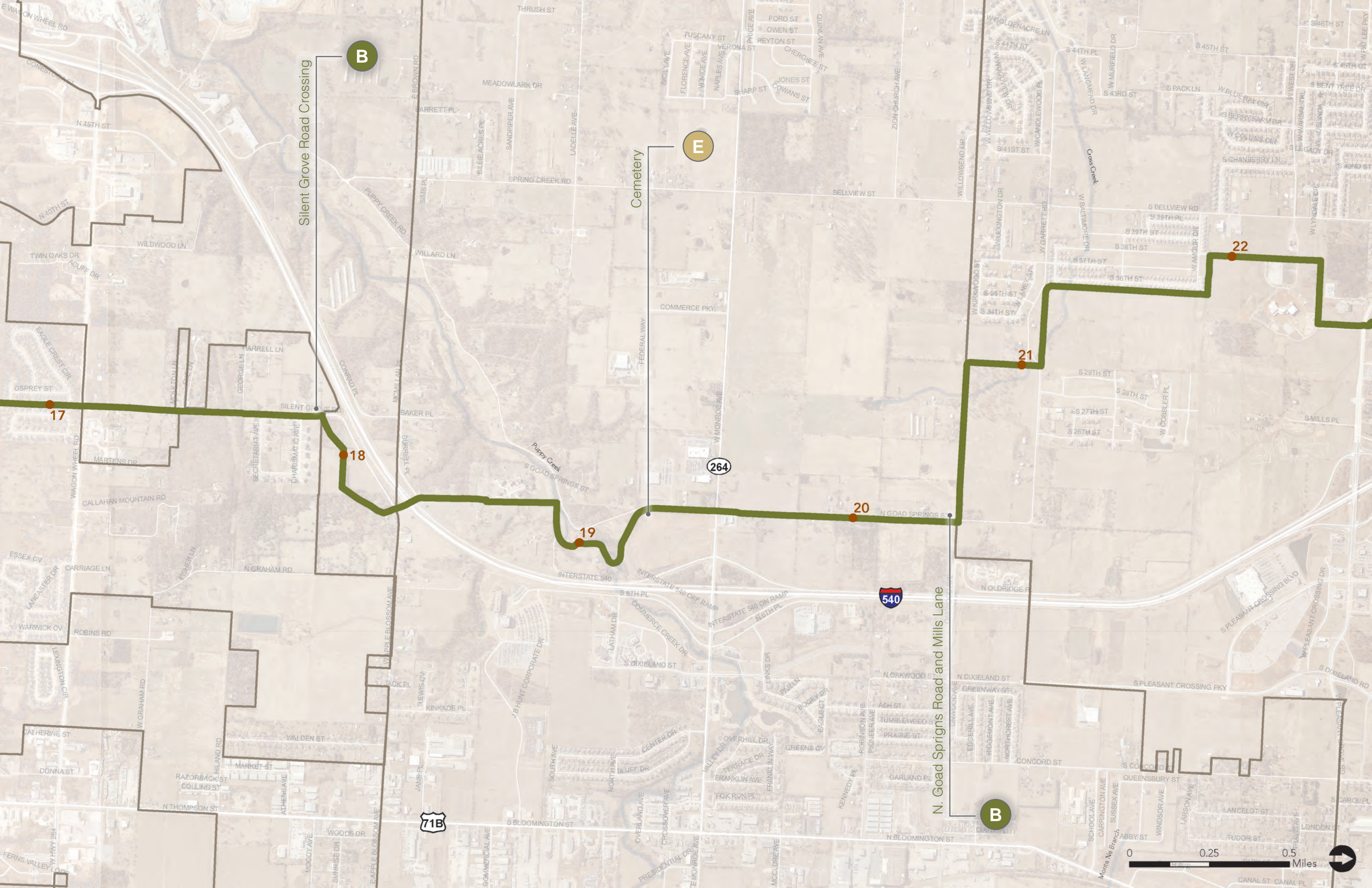

Silent Grove Road Crossing

Cemetery

N. Goad Springs Road and Mills Lane

B

E

B

17

18

19

20

21

22

264

540

71B

0 0.25 0.5 Miles





## SYSTEM-WIDE SIGN LOCATION MASTER PLAN: LOWELL



# SYSTEM-WIDE SIGN LOCATION MASTER PLAN: LOWELL

*This Page Intentionally Left Blank*



# SYSTEM-WIDE SIGN LOCATION MASTER PLAN: ROGERS

## OVERVIEW

In addition to the sign typologies indicated on the map to the right, mile markers will be placed every quarter mile along the trail. As new sections of adjoining trails are constructed, additional signage may be required for clarity and navigation. Development of new commercial centers, unveiled historic landmarks, schools, and culturally significant sites should be monitored and deemed appropriate for addition to the greenway system signage installation.



**A**  
INFORMATION  
KIOSK

**B**  
DIRECTIONAL

**C**  
MAP

**D**  
WALK/BIKE  
DESTINATION

**E**  
INTERPRETIVE  
SIGN

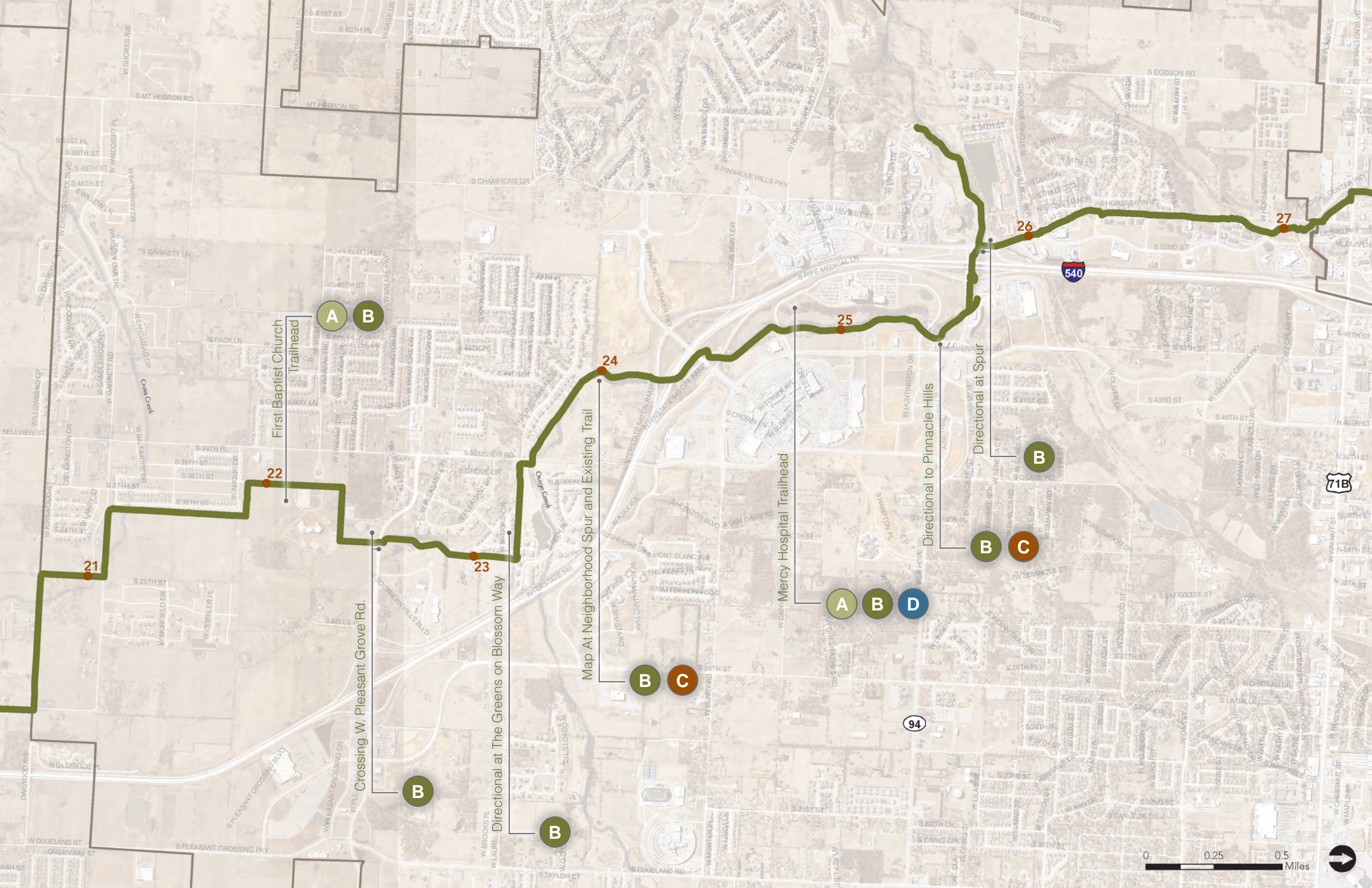

First Baptist Church  
Trailhead

**A** **B**

22

Crossing W. Pleasant Grove Rd.

**B**

Directional at The Greens on Blossom Way

**B**

Map At Neighborhood Spur and Existing Trail

24

**B**

**C**

Mercy Hospital Trailhead

**A**

**B**

**D**

25

Directional to Pinnacle Hills

**B**

**C**

Directional at Spur

**B**

26

27

540

71B

94

0 0.25 0.5 Miles







# SYSTEM-WIDE SIGN LOCATION MASTER PLAN: ROGERS



# SYSTEM-WIDE SIGN LOCATION MASTER PLAN: ROGERS

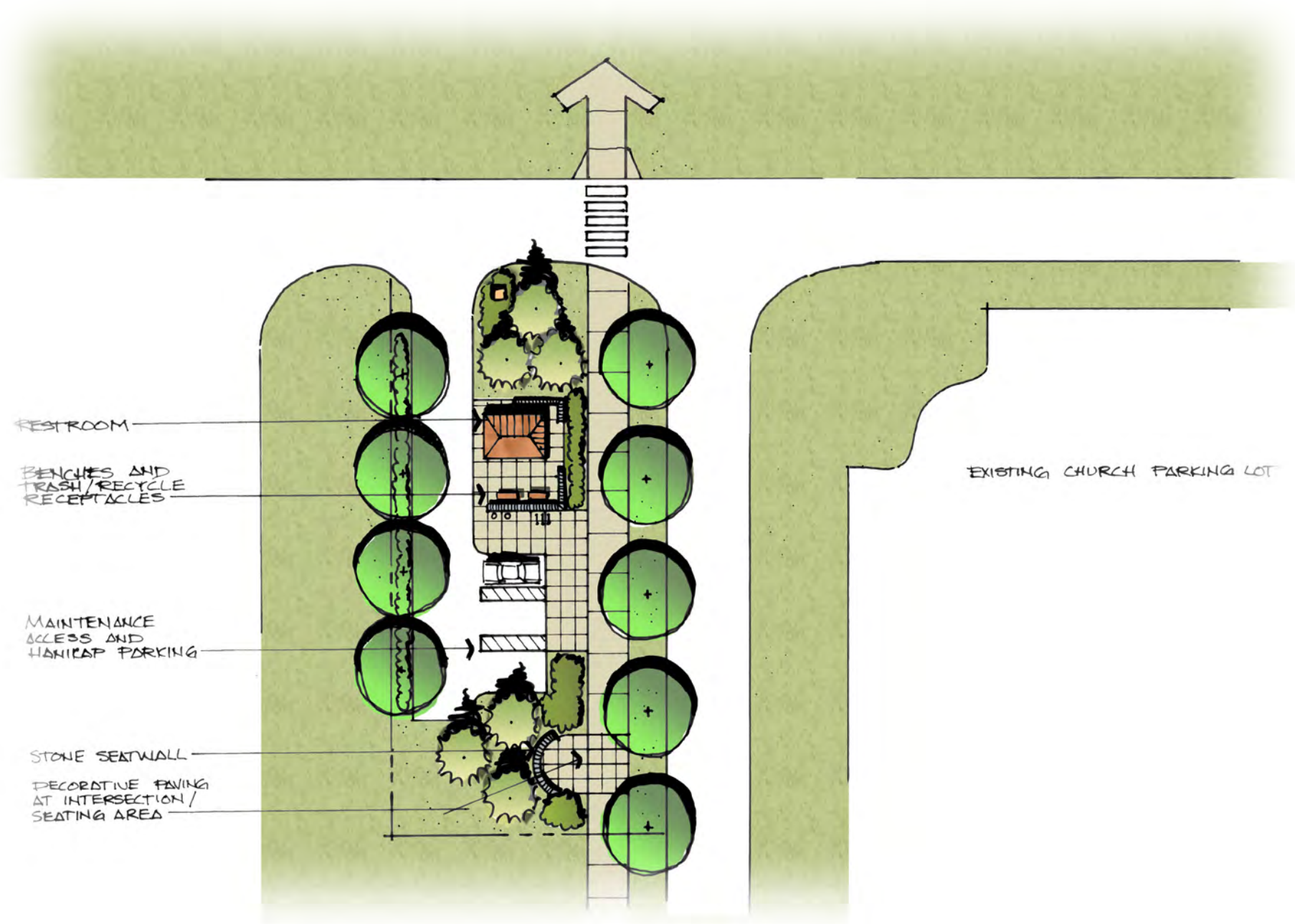



# SYSTEM-WIDE SIGN LOCATION MASTER PLAN: BENTONVILLE

## OVERVIEW

In addition to the sign typologies indicated on the map to the right, mile markers will be placed every quarter mile along the trail. As new sections of adjoining trails are constructed, additional signage may be required for clarity and navigation. Development of new commercial centers, unveiled historic landmarks, schools, and culturally significant sites should be monitored and deemed appropriate for addition to the greenway system signage installation.



**A**  
INFORMATION  
KIOSK

**B**  
DIRECTIONAL

**C**  
MAP

**D**  
WALK/BIKE  
DESTINATION

**E**  
INTERPRETIVE  
SIGN

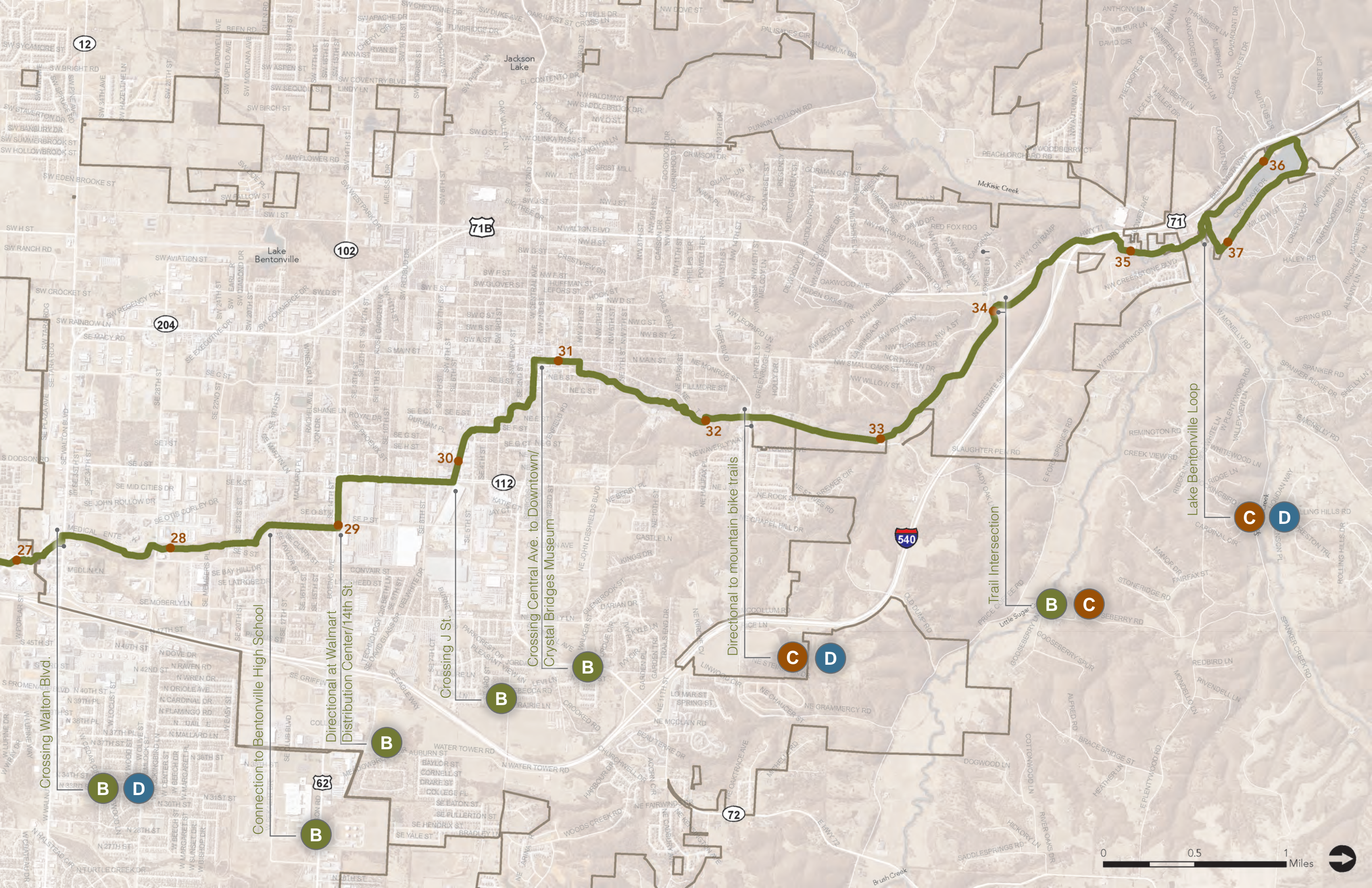

Crossing Walton Blvd.

Connection to Bentonville High School

Directional at Walmart Distribution Center/14th St.

Crossing J St.

Crossing Central Ave. to Downtown/  
Crystal Bridges Museum

Directional to mountain bike trails

Trail Intersection

Lake Bentonville Loop

12

102

71B

204

112

540

71

62

72

B

D

B

B

B

C

D

B

C

C

D

30

31

32

33

34

35

37

36

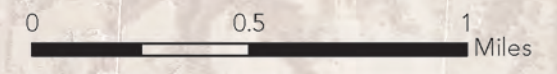



## ALTERNATIVE SOFT SURFACE SIGNAGE

### SIGN FAMILY

In addition to the 36-miles of hard surface trails, the Razorback Greenway is also connected to a series of soft surface trails. Wayfinding and navigation are equally important for both trail types. Standards for color, fonts, symbology, and design remain critical to the user experience.

A trail rating system will also be instituted to communicate level of difficulty. This will help users of multiple abilities understand which trails are suitable for their physical condition and help avoid frustration and injury.

The trail rating system is shown to the right. The system is derived from the International Mountain Bicycling Association (IMBA) which was adapted from the International Trail Marking System used to label skiing routes. The consistency in rating systems across recreational resources allows users to quickly comprehend each system.

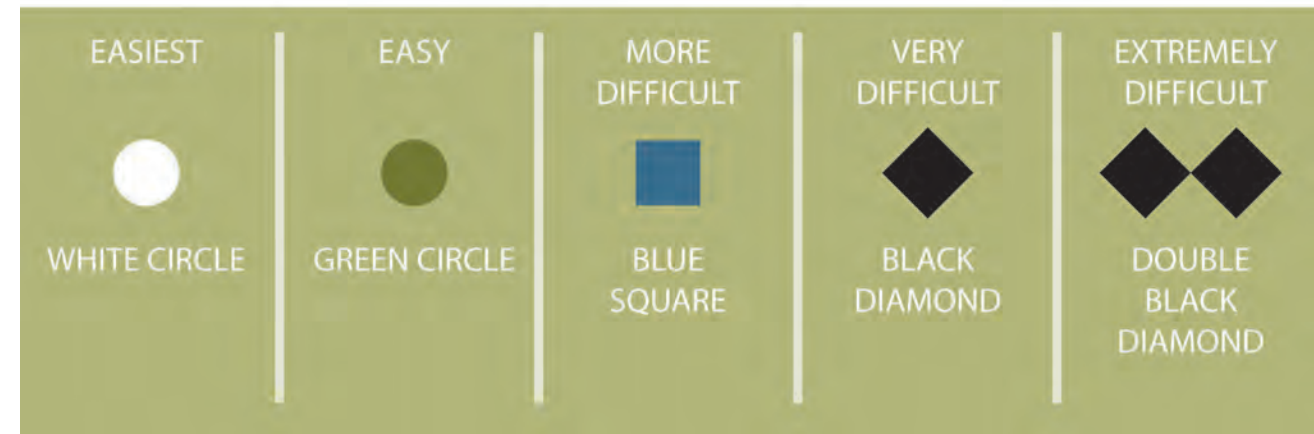

TRAIL RATING SYSTEM

# ALTERNATIVE SOFT SURFACE SIGNAGE



**INFORMATION KIOSK/  
TRAILHEAD**

**DESTINATION  
SIGNAGE**

**DIRECTIONAL  
SIGNAGE**

**REGULATORY  
SIGNAGE**

**PERMITTED USES/  
TRAIL RULES**

**ON-TRAIL  
DIRECTIONAL /  
CONFIDENCE  
MARKERS**

**INFORMATIONAL DISPLAY  
/ TRAIL MAP**



# ALTERNATIVE SOFT SURFACE SIGNAGE

## INFORMATION KIOSK/TRAILHEAD

Information Kiosks will be placed at each trailhead. Maps should include the entire trail alignment, adjacent trails (if applicable) and indicate where the user is located within the system. Trail rules, regulations, and the rating system should be included.



ELEVATION

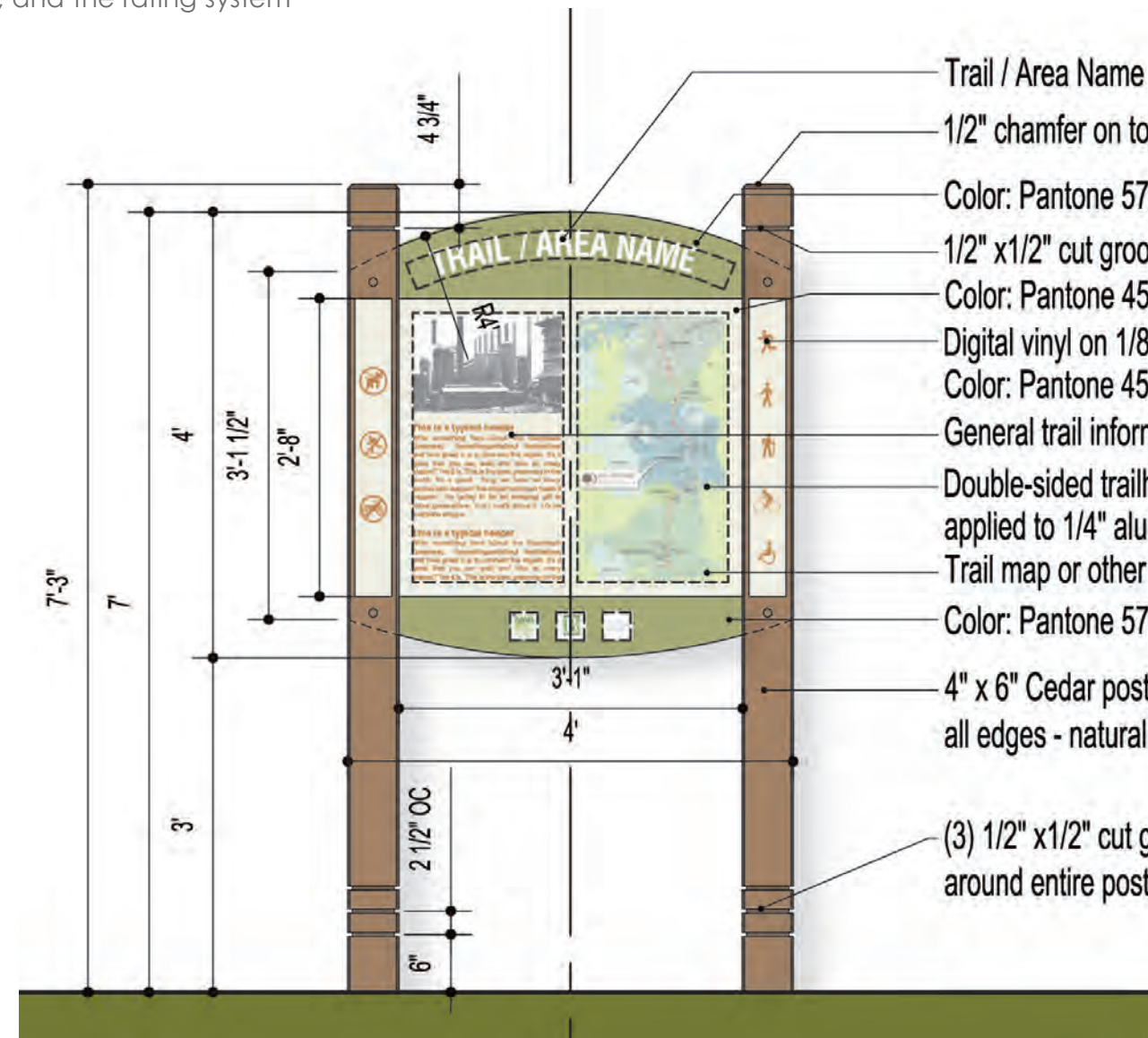

OVERALL DIMENSIONS

- Trail / Area Name
- 1/2" chamfer on top of post
- Color: Pantone 5763 U
- 1/2" x 1/2" cut groove around entire post
- Color: Pantone 454 U
- Digital vinyl on 1/8" aluminum plaque
- Color: Pantone 454 U
- General trail information, images, etc.
- Double-sided trailhead kiosk - Digital vinyl applied to 1/4" aluminum sheet
- Trail map or other graphics
- Color: Pantone 5763 U
- 4" x 6" Cedar post with 1/4" chamfer on all edges - natural finish
- (3) 1/2" x 1/2" cut grooves around entire post

# ALTERNATIVE SOFT SURFACE SIGNAGE

## INFORMATION KIOSK/TRAILHEAD

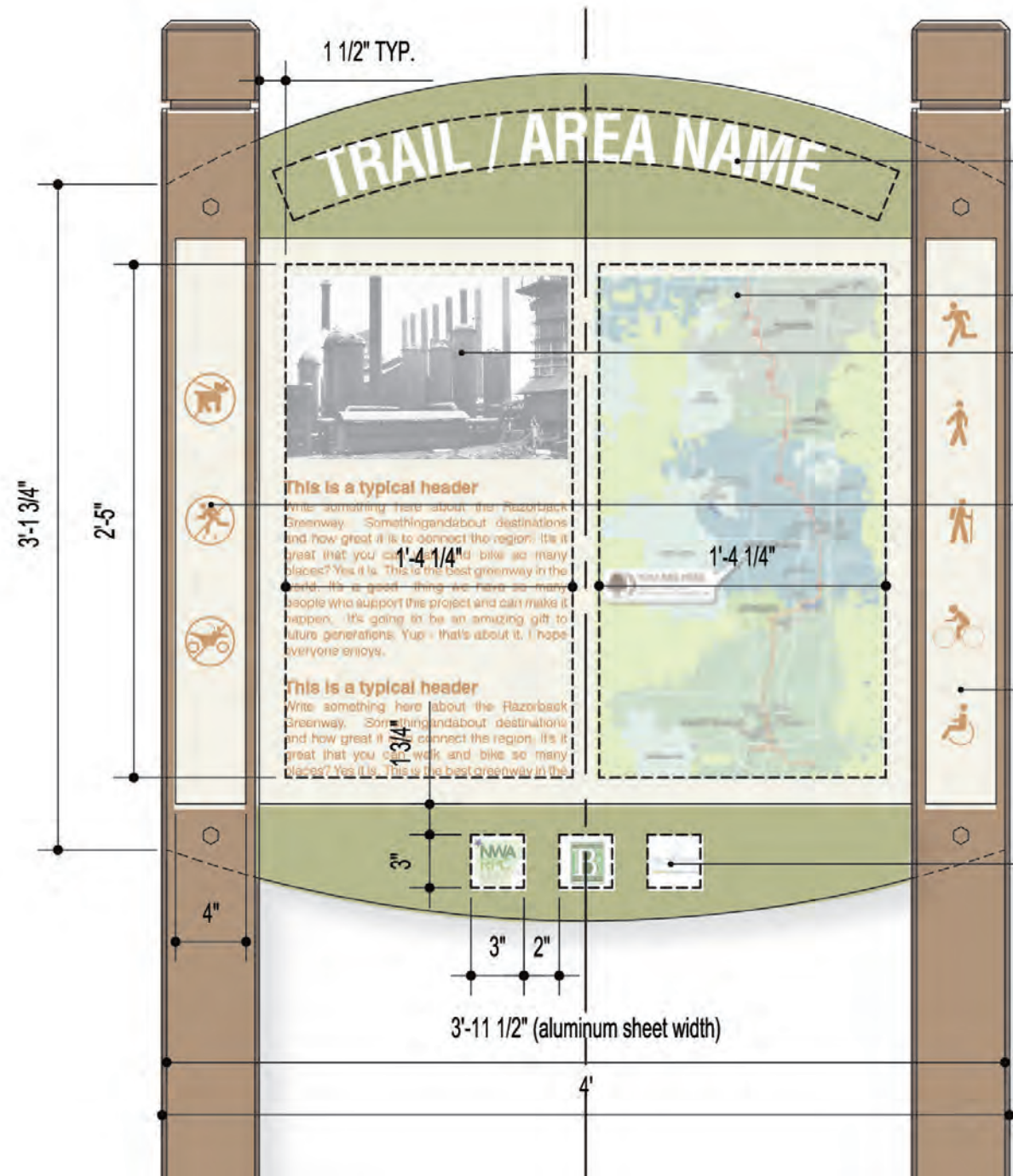

GRAPHIC LAYOUT

- 3" Trail / area name
- Map or graphic
- Informational text box - trail rating legend trail etiquette, imagery, safety, etc.
- Regulatory pictograms  
Color: Pantone 7517 U
- Permitted use pictograms  
Color: Pantone 7517 U
- 9 in<sup>2</sup> max. applicable logos

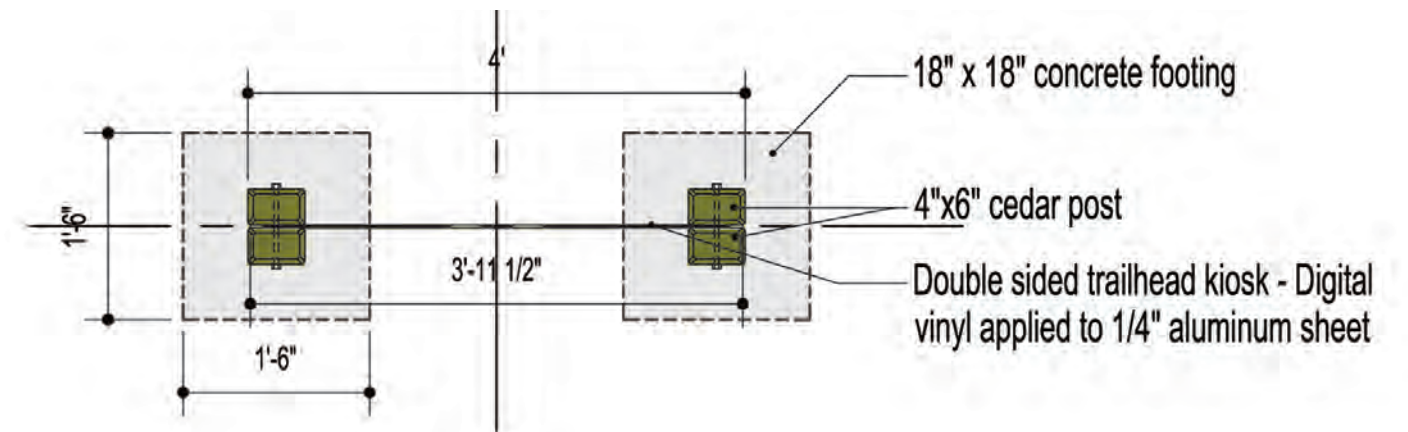

PLAN VIEW





## ALTERNATIVE SOFT SURFACE SIGNAGE

### DESTINATION AND DIRECTIONAL SIGNAGE

Destination and Directional Signage will be used on soft surface trails much like they are on hard surface trails. Key destinations will help users orient themselves along the trail and encourage use of the trail to draw visitors to nearby destinations.



# ALTERNATIVE SOFT SURFACE SIGNAGE

## DESTINATION AND DIRECTIONAL SIGNAGE

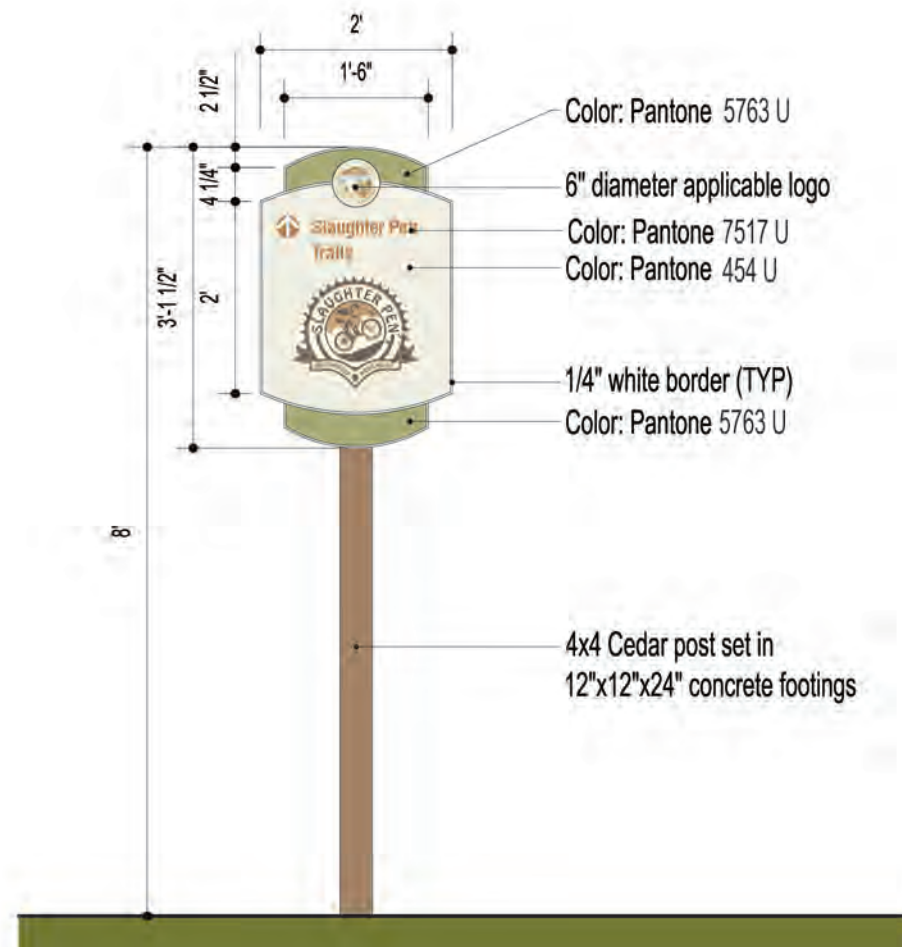

**DESTINATION SIGNAGE  
DIMENSIONS**

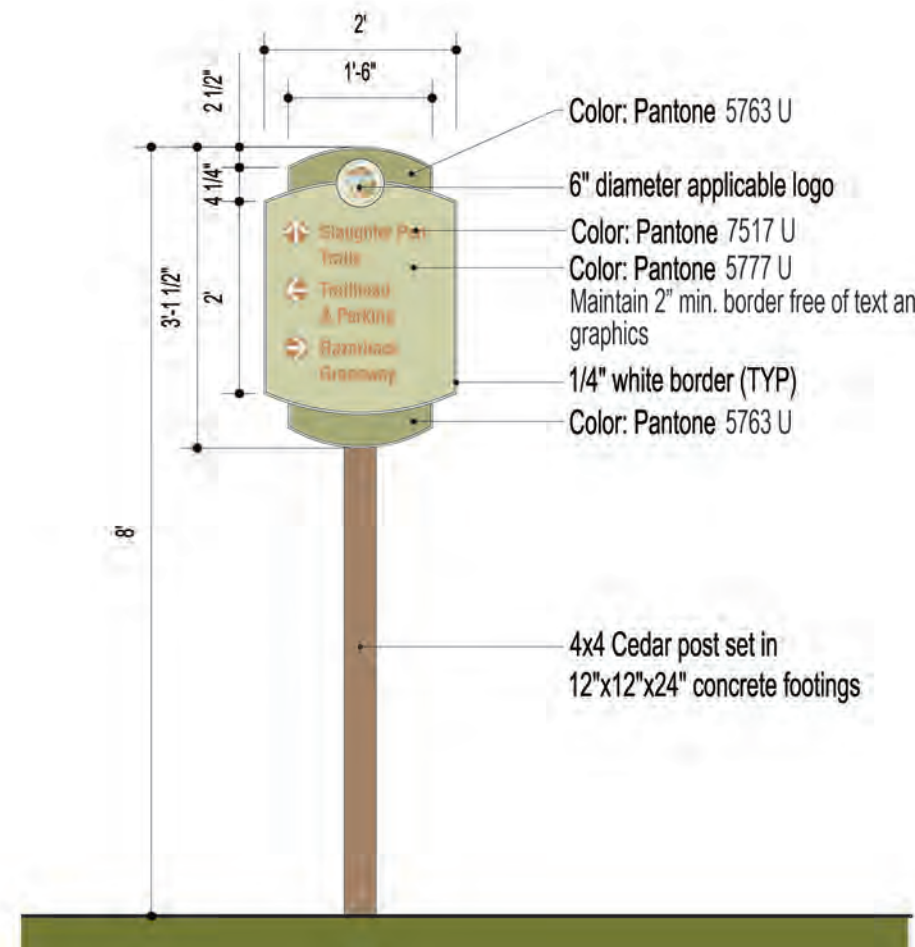

**DIRECTIONAL SIGNAGE  
DIMENSIONS**



## ALTERNATIVE SOFT SURFACE SIGNAGE

### PERMITTED USES/TRAIL RULES AND REGULATORY SIGNAGE

Rules and regulations will be posted along the trails and within trailhead or trail access areas. These signs will be developed according to site conditions and regulations of each trail.



PERMITTED USES/  
TRAIL RULES



REGULATORY SIGNAGE

# ALTERNATIVE SOFT SURFACE SIGNAGE

## PERMITTED USES/TRAIL RULES AND REGULATORY SIGNAGE

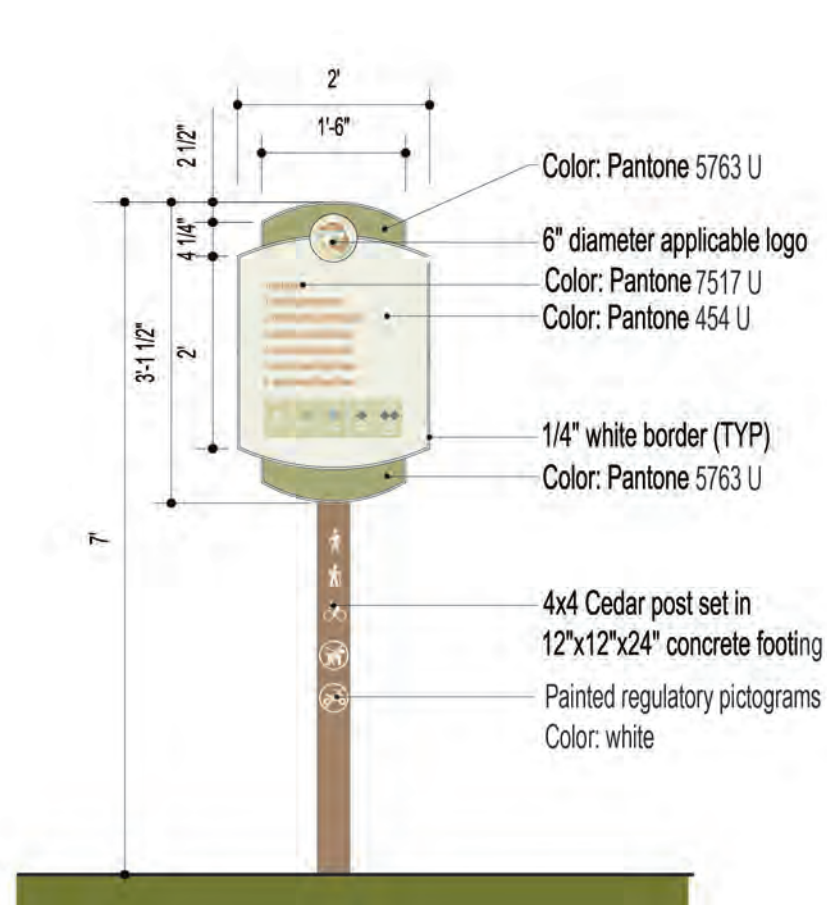

**PERMITTED USES/TRAIL RULES DIMENSIONS**

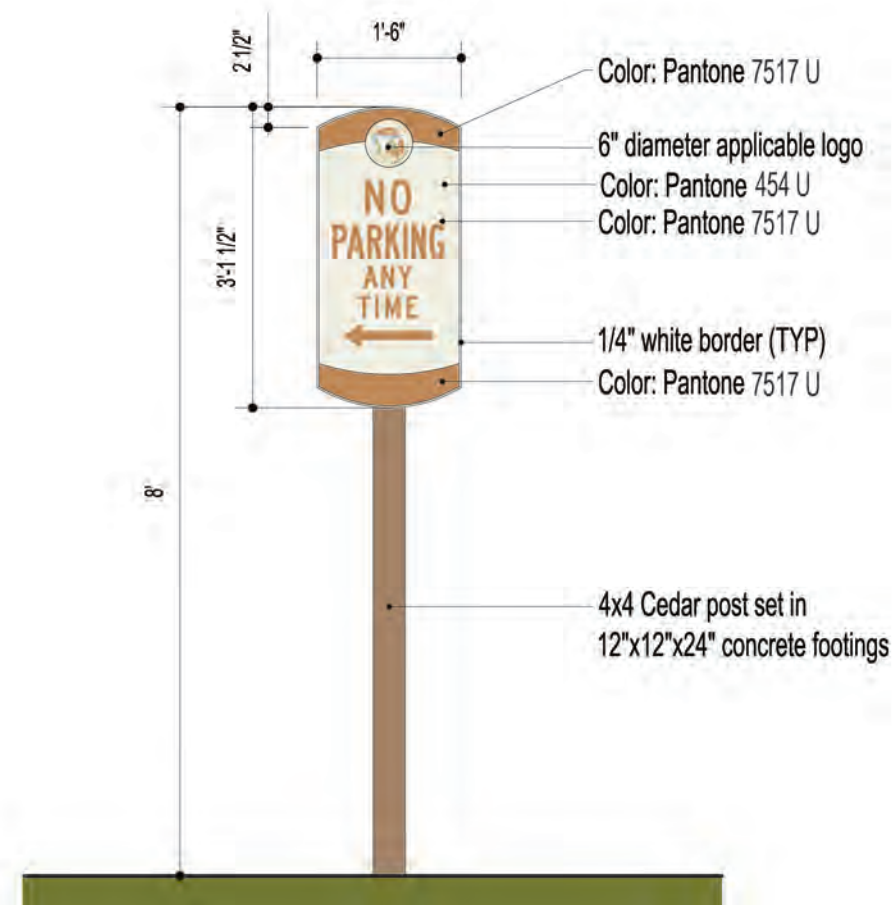

**REGULATORY SIGNAGE DIMENSIONS**



# ALTERNATIVE SOFT SURFACE SIGNAGE

## ON-TRAIL DIRECTIONAL MARKERS

Directional markers on soft surface trails serve a similar purpose as those on the hard surface Razorback Greenway. Orientation and navigation can be critical when using soft surface trails, as they typically are in densely wooded areas. Each directional indicator for adjacent trails will show the general direction of the trail and will include the degree of difficulty.

## CONFIDENCE MARKERS

Confidence markers will be used to ensure users that they are still on their intended trail path. Placement of these markers will be featured similarly to trail blazes - but are a more durable solution.

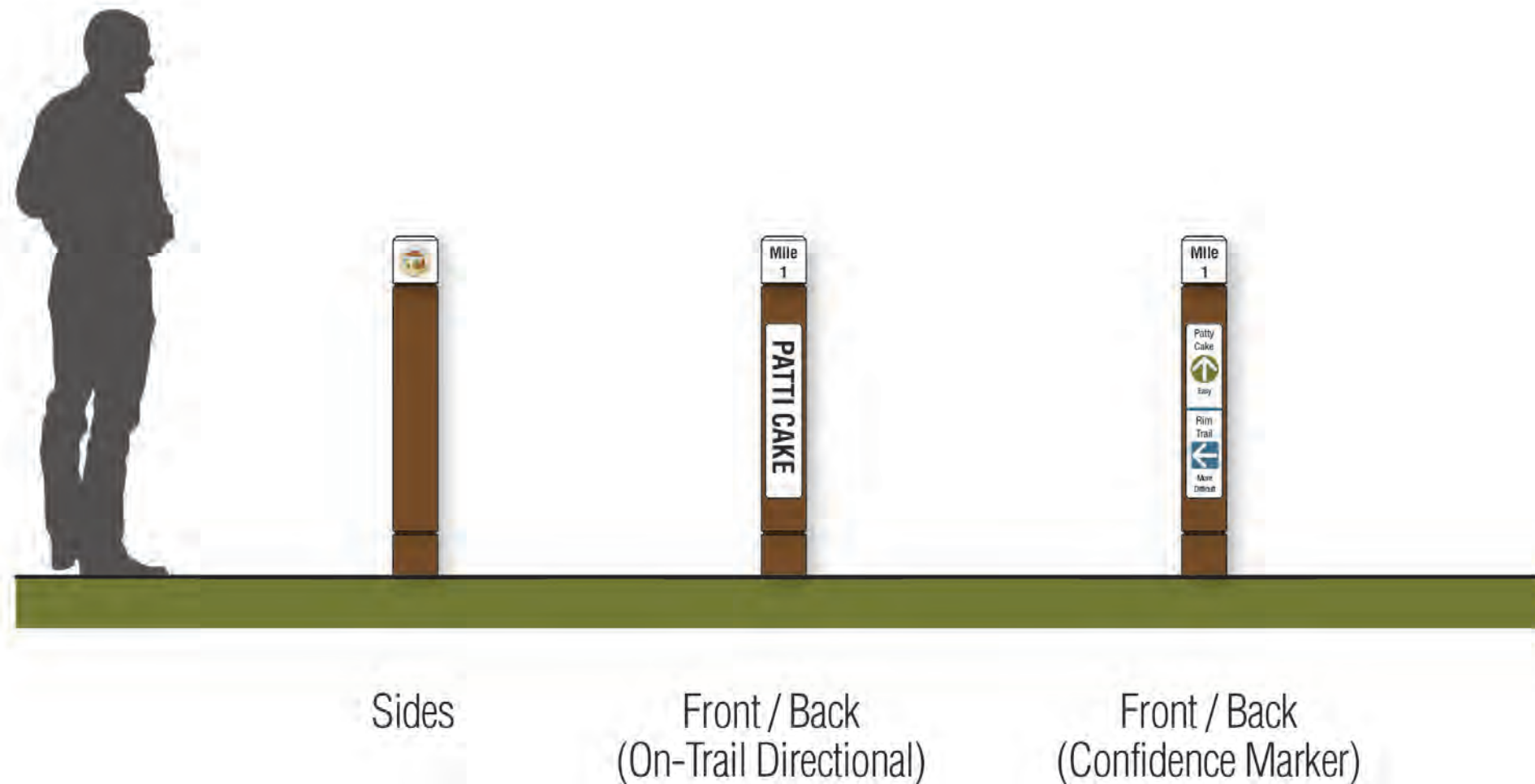

## ELEVATIONS

# ALTERNATIVE SOFT SURFACE SIGNAGE

## ON-TRAIL DIRECTIONAL AND CONFIDENCE MARKERS

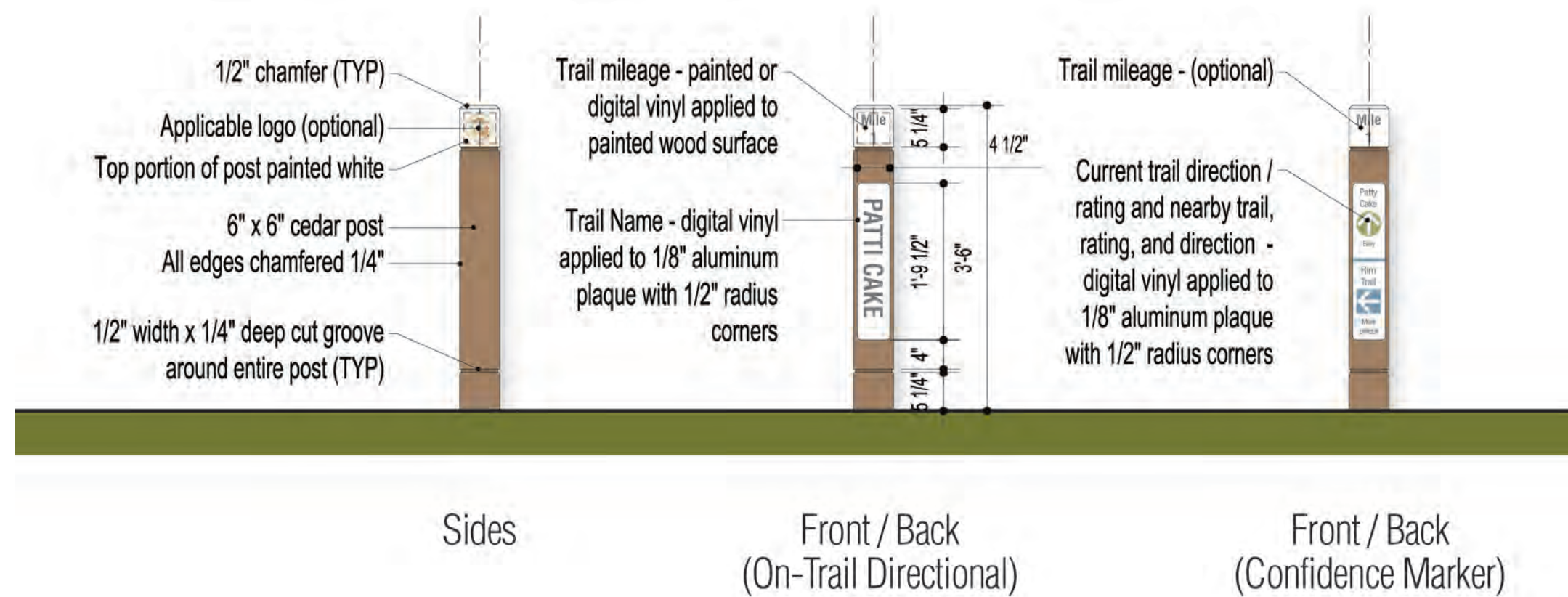

OVERALL DIMENSIONS AND GRAPHIC LAYOUT



# ALTERNATIVE SOFT SURFACE SIGNAGE

INFORMATIONAL DISPLAY / TRAIL MAP

**This is a Major Subject Header**

**This is a typical sub-header**

This is an example of informational text. The Northwest Arkansas Razorback Regional Greenway is a project that has been years in the making. The concept of a regional greenway project has been a goal of regional planners, cities, and residents of northwest Arkansas for more than two decades. This vision was supported by the Northwest Arkansas Regional Planning Commission (NWARPC), which in 2000 began a long-range planning process that included regional trails as a key component. A task force formed by the NWARPC conducted public meetings and facilitated a coordinated effort among the communities of northwest Arkansas.

This is an example of informational text. The Northwest Arkansas Razorback Regional Greenway is a project that has been years in the making. The concept of a regional greenway project has been a goal of regional planners, cities, and residents of northwest Arkansas for more than two decades. This vision was supported by the Northwest Arkansas Regional Planning Commission (NWARPC), which in 2000 began a long-range planning process that included regional trails as a key component. A task force formed by the NWARPC conducted public meetings and facilitated a coordinated effort among the communities of northwest Arkansas.

**Blowing Springs** In Bella Vista Walking & Biking Trails

**BLOWING**

**SPRINGS**

**INFORMATIONAL DISPLAY / TRAIL MAP**

# ALTERNATIVE SOFT SURFACE SIGNAGE

INFORMATIONAL DISPLAY / TRAIL MAP

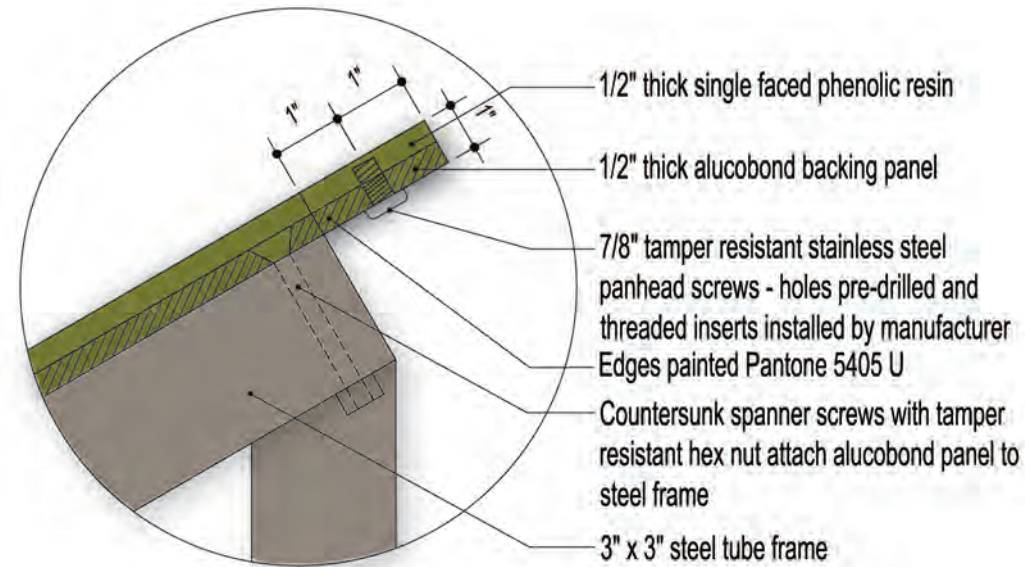

PANEL MOUNT

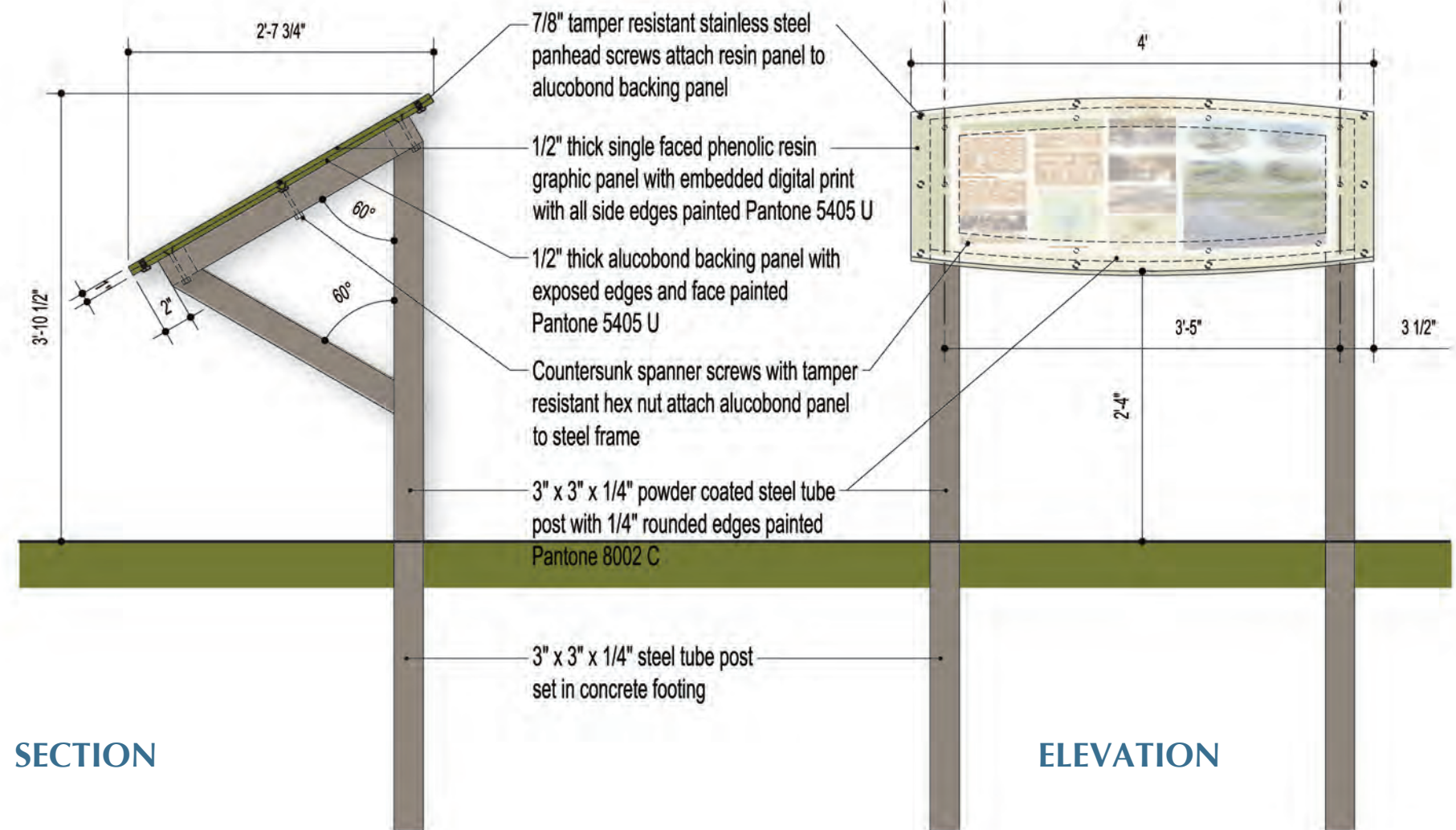



# ALTERNATIVE SOFT SURFACE SIGNAGE

## INFORMATIONAL DISPLAY / TRAIL MAP

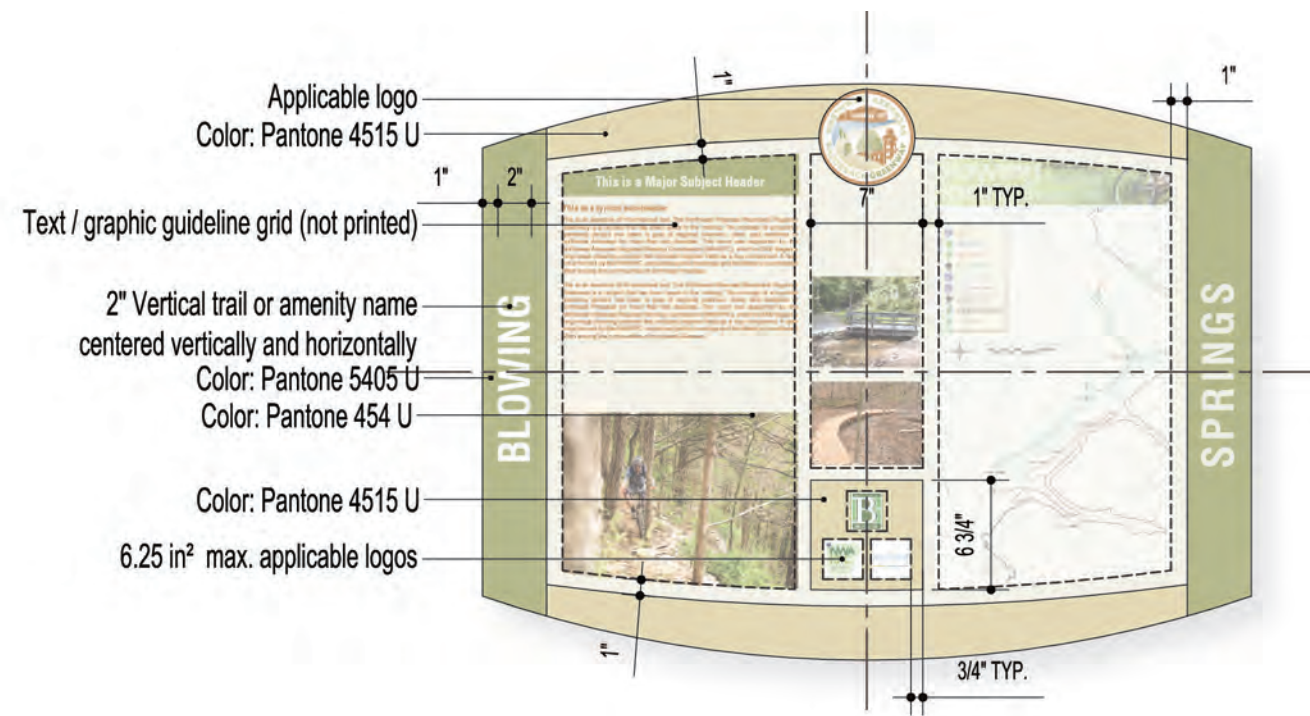

GRAPHIC LAYOUT

## TYPOGRAPHY

### Vertical "RAZORBACK GREENWAY" banner

- Font = Helvetica LT - Bold Condensed
- Align = Center
- Size = 2"
- Tracking = 100
- Color = Pantone 454 U

### Major Subject Header Text

- Font = Helvetica LT - Bold Condensed
- Align = Center
- Size = 1"
- Color = Pantone 7517 U

### Sub-Header Text

- Font = Helvetica LT - Bold Condensed
- Align = Left
- Size = 3/4"
- Color = Pantone 7517 U

### Informational / Body Text

- Font = Helvetica LT - Light
- Align = Fully justified
- Size = 5/8"
- Color = Pantone 7517 U

# ALTERNATIVE SOFT SURFACE SIGNAGE

*This Page Intentionally Left Blank*



# ALTERNATIVE SOFT SURFACE SIGNAGE

## ALTERNATIVE SOFT SURFACE SIGNAGE GUIDELINES FOR TRAILHEAD AND INFORMATION KIOSKS

**NOTES:**  
1. All wood to be pressure-treated clear grade rough cut Eastern Red Cedar.  
2. All hardware to be hot dip galvanized.

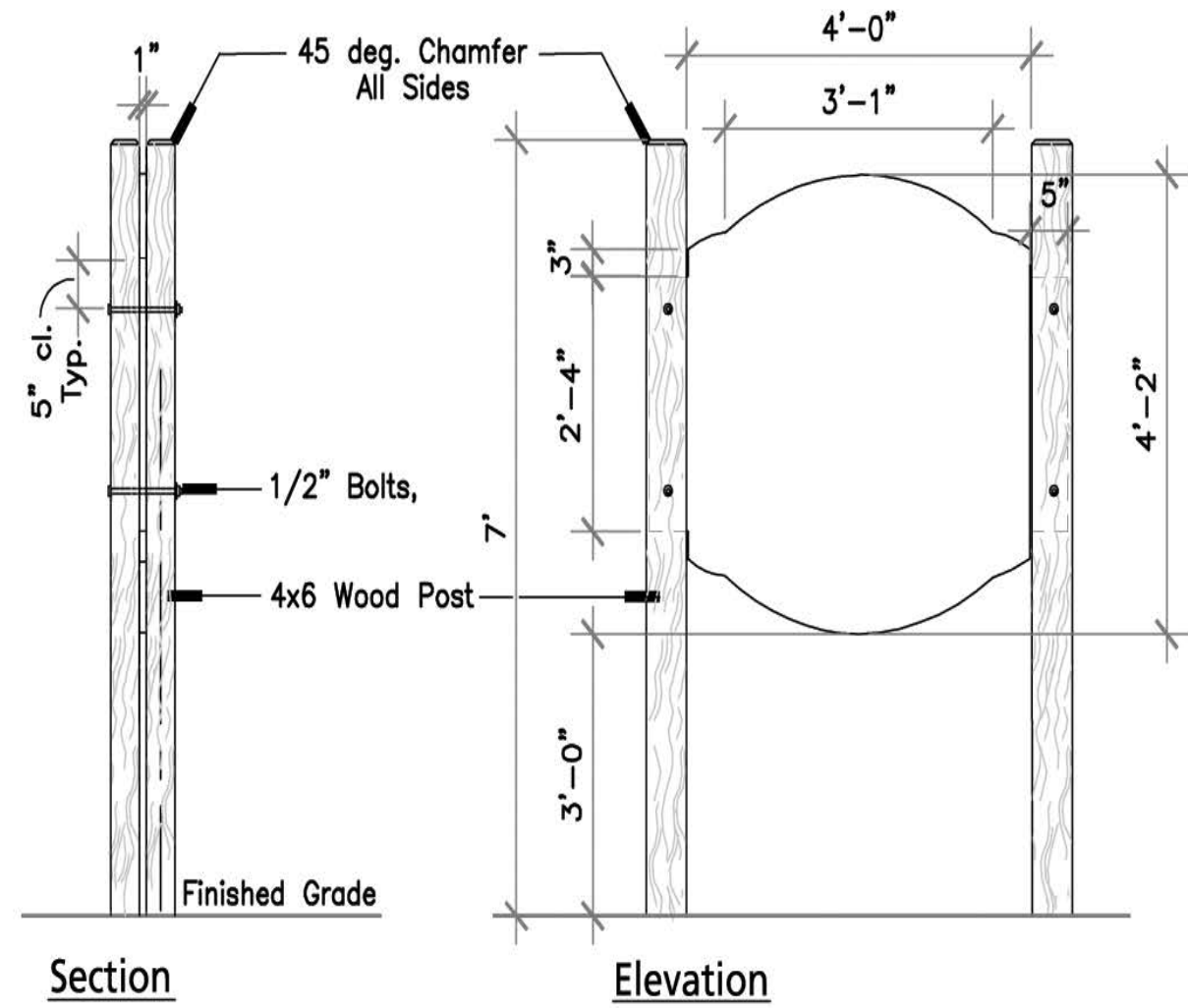

# ALTERNATIVE SOFT SURFACE SIGNAGE

## ALTERNATIVE SOFT SURFACE SIGNAGE GUIDELINES FOR TRAILHEAD AND INFORMATION KIOSKS

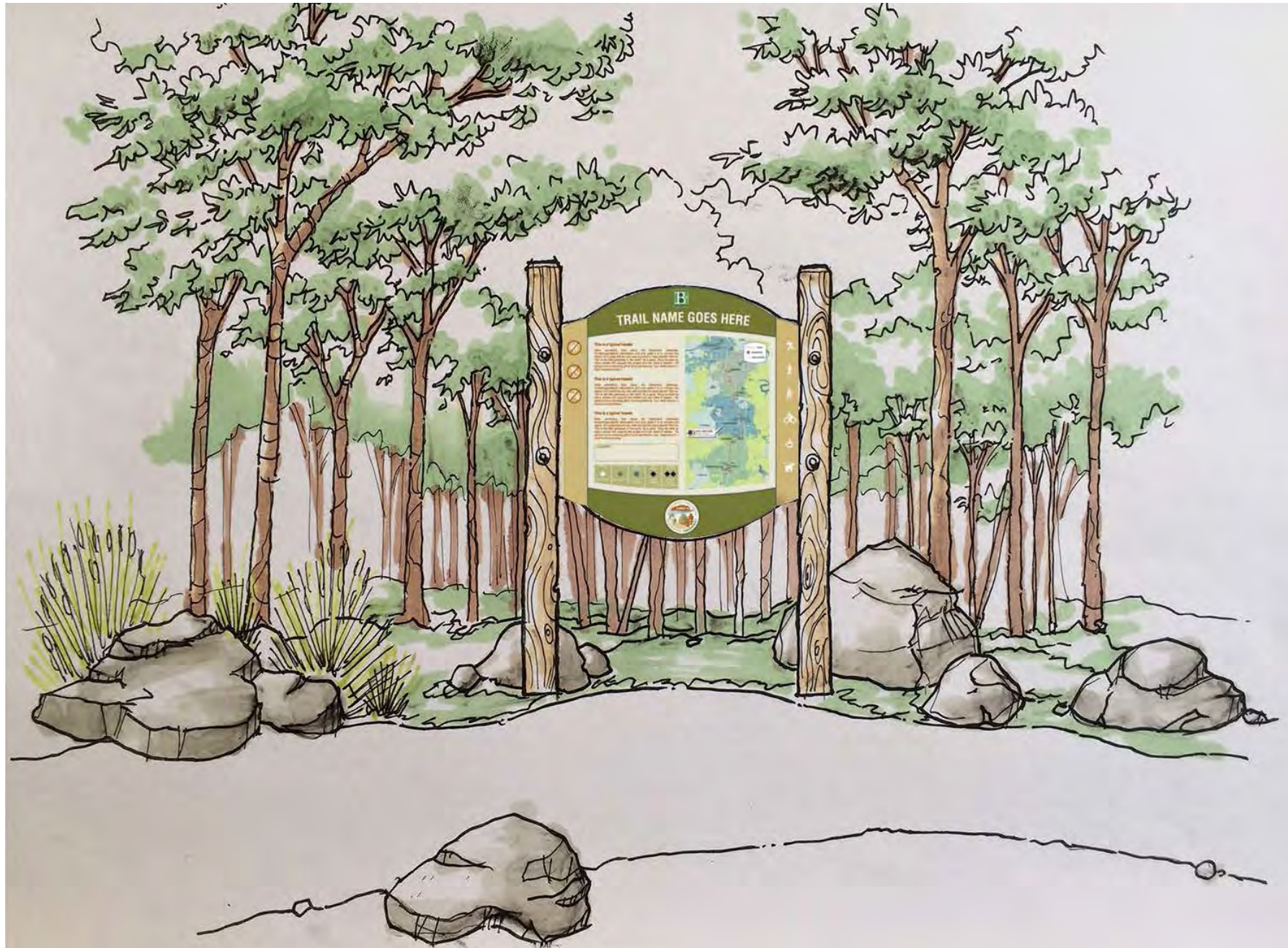



# ALTERNATIVE SOFT SURFACE SIGNAGE

## ALTERNATIVE SOFT SURFACE SIGNAGE GUIDELINES FOR INTERPRETIVE SIGNAGE

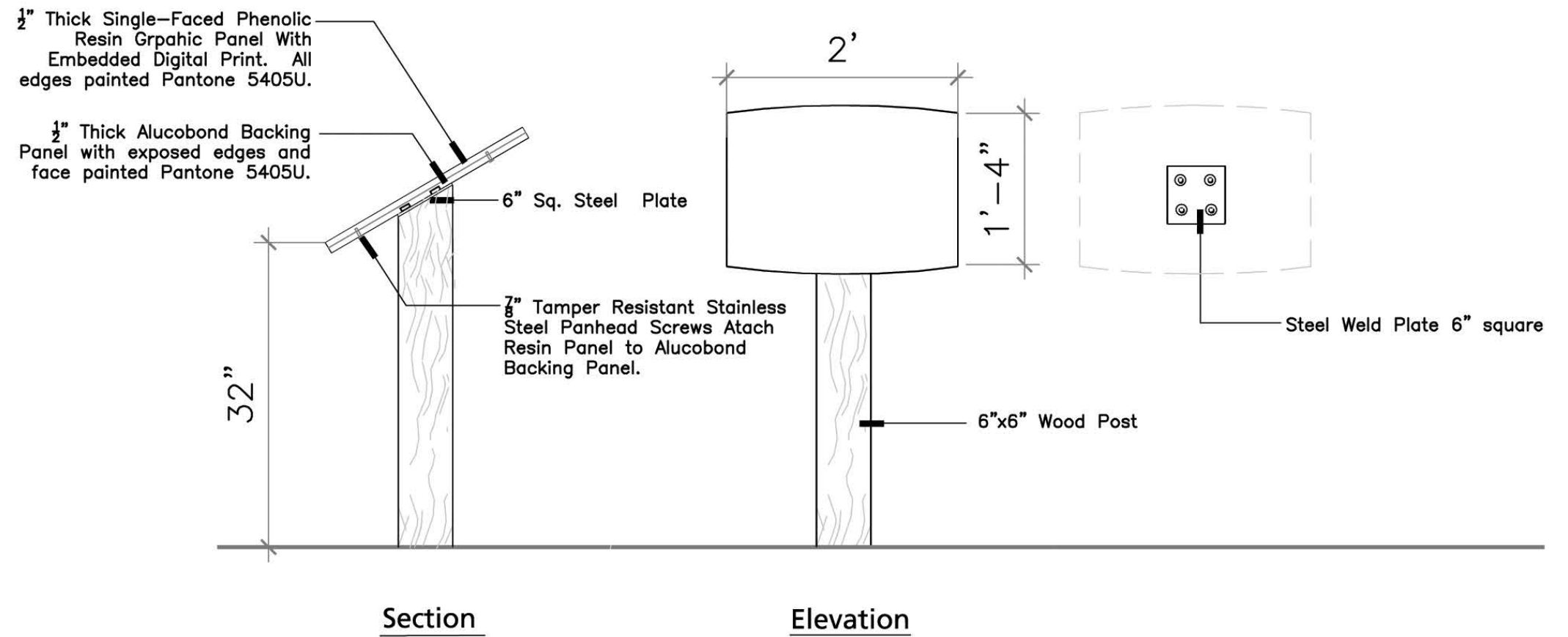

# ALTERNATIVE SOFT SURFACE SIGNAGE

## ALTERNATIVE SOFT SURFACE SIGNAGE GUIDELINES FOR TRAIL CONFIDENCE MARKERS

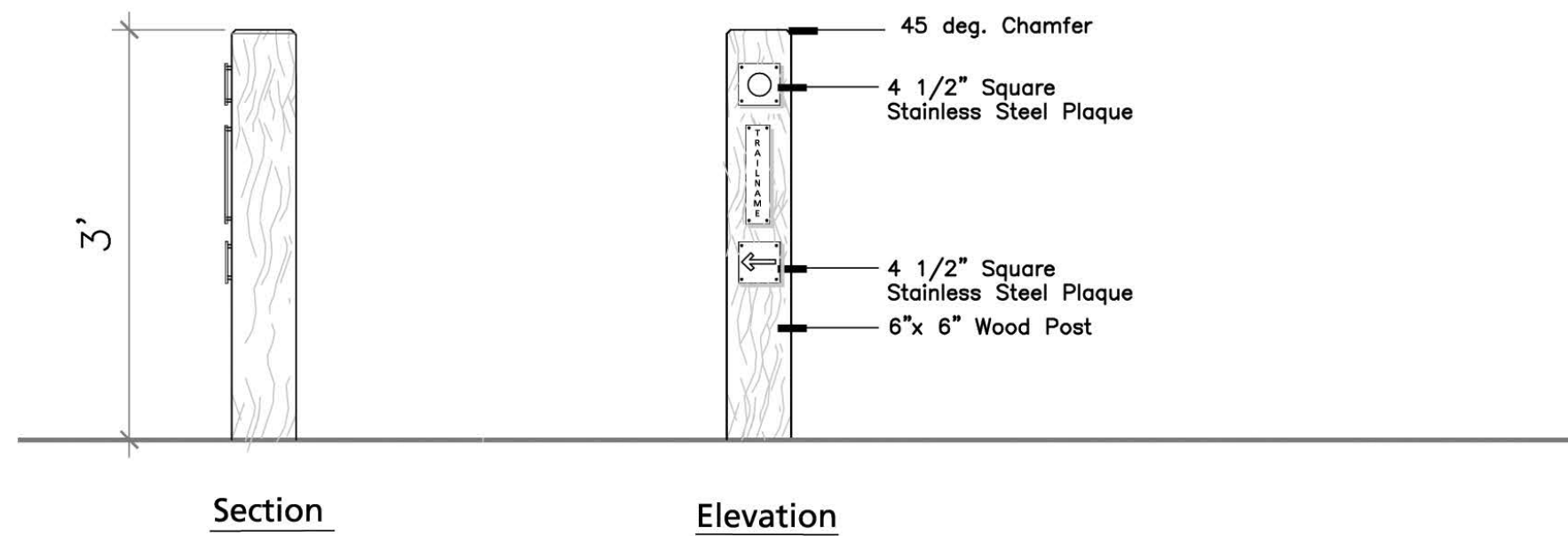

### TRAIL CONFIDENCE MARKERS