

City of Fayetteville Staff Review Form

2014-0289

Legistar File ID

7/15/2014

City Council Meeting Date - Agenda Item Only
 N/A for Non-Agenda Item

Terry Gulley

6/27/2014

Transportation Services /
 Transportation Services Department
 Division / Department

Submitted By

Submitted Date

Action Recommendation:

A resolution awarding Bid 14-35 to and authorizing the purchase of retaining wall blocks from Industrial Precast, Inc. for the unit prices shown on the attached bid tabulation, as needed, and authorizing the use of other bidders based on price and availability.

Budget Impact:

2100.5500.5814.00	Street
Account Number	Fund
02053/5500	Sidewalk Improvements
Project Number	Project Title
Budgeted Item? <u>Yes</u>	Current Budget \$ 1,042,000.00
	Funds Obligated \$ 31,854.21
	Current Balance \$ 1,010,145.79
Does item have a cost? <u>Yes</u>	Item Cost \$ -
Budget Adjustment Attached? <u>No</u>	Budget Adjustment \$ -
	Remaining Budget \$ 1,010,145.79

V20140610

Previous Ordinance or Resolution # _____

ENTERED
6/27/14

Original Contract Number: _____

Approval Date: _____

Comments: The "item cost" box has been left blank because the exact item cost will vary depending upon the Transportation Division's fluctuating needs based on citizen service requests received, construction project progress, and other variable factors.

6/30/14

Paul A. Bender 6-30-2014

Ann Man 7-1-14

[Signature]

ENTERED
6/30/14
PK



CITY COUNCIL AGENDA MEMO

MEETING OF JULY 15, 2014

TO: Mayor and City Council
THRU: Don Marr, Chief of Staff
FROM: Terry Gulley, Transportation Services Director
DATE: June 26, 2014
SUBJECT: Bid 14-35, Retaining Wall Blocks

RECOMMENDATION:

A resolution awarding Bid 14-35 to and authorizing the purchase of retaining wall blocks from Industrial Precast, Inc. for the unit prices shown on the attached bid tabulation, as needed, and authorizing the use of other bidders based on price and availability.

BACKGROUND:

The purchase of bulk construction materials and services is necessary to maintain current infrastructure and to implement projects outlined in the 2013-2017 Capital Improvements Program and annual budget and work program. Sealed bids in accordance with State statutes, City ordinances, and purchasing procedures were publicly read and the results are attached to this memo.

DISCUSSION:

The low bid for retaining wall blocks was submitted by Industrial Precast, Inc.

BUDGET/STAFF IMPACT:

Funds for the acquisition of materials have been budgeted in various capital projects within the Sales Tax Capital Improvements Fund and Street Fund operating programs.

Attachments:

Bid 14-35 Tabulation
Bid Submittal

RESOLUTION NO. _____

A RESOLUTION TO AWARD BID #14-35 AND AUTHORIZE THE PURCHASE OF RETAINING WALL BLOCKS FROM INDUSTRIAL PRECAST, INC. IN VARIABLE AMOUNTS AS NEEDED, AND TO AUTHORIZE THE USE OF OTHER BIDDERS BASED ON PRICE AND AVAILABILITY AS NEEDED THROUGH THE END OF CALENDAR YEAR 2014

BE IT RESOLVED BY THE CITY COUNCIL OF THE CITY OF FAYETTEVILLE, ARKANSAS:

Section 1. That the City Council of the City of Fayetteville, Arkansas hereby awards Bid #14-35 and authorizes the purchase of retaining wall blocks from Industrial Precast, Inc. in variable amounts as needed, and further authorizes the use of other bidders based on price and availability as needed through the end of calendar year 2014.

PASSED and APPROVED this 15th day of July, 2014.

APPROVED:

ATTEST:

By: _____
LIONELD JORDAN, Mayor

By: _____
SONDRA E. SMITH, City Clerk/Treasurer



Bid: 14-35
 Date: 6/26/2014
 Time: 3:00 PM
 City of Fayetteville

Bid 14-35, Retaining Wall Blocks

		Industrial Precast		LJB Construction		
Redi-Rock® 28" Series Wall System or Equal						
Item	DESCRIPTION	QTY	PRICE EACH	EXTENDED PRICE	PRICE EACH	EXTENDED PRICE
1	Top Block - 28" Series with Cobble Stone Face	100	\$ 81.85	= \$ 8,185.00	\$ 110.00	= \$ 11,000.00
2	Half Top Block - 28" Series with Cobble Stone Face	8	\$ 55.60	= \$ 444.80	\$ 65.00	= \$ 520.00
3	Middle Block - 28" Series with Cobble Stone Face	174	\$ 91.00	= \$ 15,834.00	\$ 113.50	= \$ 19,749.00
4	Half Middle Block - 28" Series with Cobble Stone Face	2	\$ 58.60	= \$ 117.20	\$ 65.00	= \$ 130.00
5	Bottom Block - 28" series with Cobble Stone Face	90	\$ 93.75	= \$ 8,437.50	\$ 113.50	= \$ 10,215.00
6	Half Bottom Block - 28" Series with Cobble Stone Face	1	\$ 58.60	= \$ 58.60	\$ 65.00	= \$ 65.00
7	Bottom Block - 41" Series with Cobble Stone Face	15	\$ 99.50	= \$ 1,492.50	\$ 150.00	= \$ 2,250.00
			Total Bid :	\$ 34,569.60	Total Bid :	\$ 43,929.00

*NOTICE: Bid award is contingent upon vendor meeting minimum specifications and formal authorization by City

CERTIFIED: P. Vice Candy Kuf 6-26-14
 P. VICE, PURCHASING MANAGER WITNESS DATE



City of Fayetteville, Arkansas
Purchasing Division – Room 306
113 W. Mountain
Fayetteville, AR 72701
Phone: 479.575.8220

TDD (Telecommunication Device for the Deaf): 479.521.1316

INVITATION TO BID

INVITATION TO BID: Bid 14-35, Retaining Wall Blocks – Materials Only

DEADLINE: Thursday, June 26, 2014 before 3:00 PM, Local Time

DELIVERY LOCATION: Room 306 – 113 W. Mountain, Fayetteville, AR 72701

PURCHASING AGENT: Andrea Foren, CPPO, CPPB, aforen@fayetteville-ar.gov

DATE OF ISSUE AND ADVERTISEMENT: Saturday, June 14, 2014

INVITATION TO BID
Bid 14-35, Retaining Wall Blocks – Materials Only

No late bids will be accepted. Bids shall be submitted in sealed envelopes labeled with the name and address of the bidder.

All bids shall be submitted in accordance with the attached City of Fayetteville specifications and bid documents attached hereto. Each bidder is required to fill in every blank and shall supply all information requested; failure to do so may be used as basis of rejection.

The undersigned hereby offers to furnish & deliver the articles or services as specified, at the prices & terms stated herein, and in strict accordance with the specifications and general conditions of bidding, all of which are made a part of this offer. This offer is not subject to withdrawal unless upon mutual written agreement by the Proposer/Bidder and City Purchasing Manager.

Name of Firm: Industrial Precast Inc.

Contact Person: Max Blake Title: Sales Manager

E-Mail: MaxBlake@cox.net Phone: 479.420.1626

Business Address: 7201 So 28th

City: Fort Smith State: AR Zip: 72908

Signature: Max Blake Date: 6-25-2014

City of Fayetteville
 Bid 14-35, Retaining Wall Blocks – Materials Only
 Bid Form

City of Fayetteville, Arkansas				
Bid 14-35, Retaining Wall Blocks				
Bid # 14-35	Date Issued: Saturday June 14, 2014	Date and Time Of Bid Opening: 3:00 PM, Thursday June 26, 2014		
Date Required: As specified				
F.O.B Fayetteville, Arkansas		Purchasing Agent Contact Information: Andrea Foren, CPPO, CPPB, (479) 575-8220, aforen@ci.fayetteville.ar.us		
Redi-Rock® 28" Series Wall System or Equal				
Item	DESCRIPTION	QTY	PRICE EACH	EXTENDED PRICE
1	Top Block - 28" Series with Cobble Stone Face	100	81.85	= \$ 8185.00
2	Half Top Block - 28" Series with Cobble Stone Face	8	55.60	= \$ 444.80
3	Middle Block - 28" Series with Cobble Stone Face	174	91.00	= \$ 15834.00
4	Half Middle Block - 28" Series with Cobble Stone Face	2	58.60	= \$ 117.20
5	Bottom Block - 28" series with Cobble Stone Face	90	93.75	= \$ 8437.50
6	Half Bottom Block - 28" Series with Cobble Stone Face	1	58.60	= \$ 58.60
7	Bottom Block - 41" Series with Cobble Stone Face	15	99.50	= \$ 1492.50
Total Bid :				\$ 34569.60
<p>Bid pricing shall be inclusive of materials, shipping, and any applicable delivery charges. The City shall be responsible for all offloading. Bid pricing shall NOT include taxes. All bidders shall refer to bid document for full details regarding delivery.</p>				
<p>NAME OF VENDOR <i>Industrial Precast Inc.</i></p>				
<p>THIS BID FORM CONTINUES ON THE NEXT PAGE. . .</p>				

Bids shall be submitted on this bid form *in its entirety* AND *accompanied by descriptive literature* on the products being bid. The City reserves the right to award this bid based on the City's best interest at the time of product order.

EXECUTION OF BID -

Actual specification of any deficient item shall be noted on the bid sheet or separate attachment. If specifications of item bid differ from provided literature, deviation shall be documented and certified by the manufacturer as a regular production option.

Upon signing this Bid, the bidder certifies that:

1. He/she has read and agrees to the requirements set forth in this proposal, including specifications, terms, standard conditions, and any pertinent information regarding the articles being bid on.
2. Unless otherwise noted and explained, the unit bid and listed meets or exceeds all of these requirements as specified by The City of Fayetteville.
3. The Bidder can and will comply with all specifications and requirements for delivery, documentation and support as specified herein.
4. I, as an officer of this organization, or per the attached letter of authorization, am duly authorized to certify the information provided herein is accurate and true.
5. Bidder shall comply with all State and Federal Equal Opportunity and Non-Discrimination requirements and conditions of employment in addition to all federal, state, and local laws.
6. Bidder shall disclose any possible conflict of interest with the City of Fayetteville, including, but not limited to, any relationship with any City of Fayetteville employee. Response shall disclose if a known relationship exists between any principal or employee of your firm and any City of Fayetteville employee or elected City of Fayetteville official. If no relationship exists, this should also be stated in your response. Failure to disclose such a relationship may result in cancellation of a purchase and/or contract as a result of your response.

 MB 1.) NO KNOWN RELATIONSHIP EXISTS

_____ 2.) RELATIONSHIP EXISTS (Please explain): _____

7. Bidder will perform the Work in compliance with all applicable trench safety standards set forth in Occupational Safety and Health Administration (OSHA) Part 1926 – Subpart P – Excavations.
8. As A bidder on this project, you are required to provide debarment/suspension certification indicating that you are in compliance with the below Federal Executive Order. Certification can be done by completing and signing this form.
 - a. Federal Executive Order (E.O.) 12549 “Debarment and Suspension” requires that all contractors receiving individual awards, using federal funds, and all sub-recipients certify that the organization and its principals are not debarred, suspended, proposed for debarment, declared ineligible, or voluntarily excluded by any Federal department or agency from doing business with the Federal Government.
 - b. Your signature below certifies that neither you nor your principal is presently debarred, suspended, proposed for debarment, declared ineligible, or voluntarily excluded from participation in this transaction by any federal department or agency.

Unsigned bids will be rejected. Items marked * are mandatory for consideration.

*NAME OF FIRM: Industrial Precast INC.
Purchase Order/Payments shall be issued to this name

*D/B/A or Corporation Name _____

*BUSINESS ADDRESS: 7201 South 28th

*CITY: Fort Smith *STATE: Arkansas *ZIP: 72908

*PHONE: 479.646.7222 FAX: 479.484.1657

*E-MAIL: maxblake@cox.net

*BY: (PRINTED NAME) Max Blake

*AUTHORIZED SIGNATURE: Max Blake

*TITLE: Sales Manager

DUNS NUMBER: _____ CAGE NUMBER: _____

*TAX ID NUMBER: 26-0516905

Acknowledge Addendums:

Addendum No. _____ Dated: _____ Acknowledged by: _____

Addendum No. _____ Dated: _____ Acknowledged by: _____

Addendum No. _____ Dated: _____ Acknowledged by: _____

Addendum No. _____ Dated: _____ Acknowledged by: _____

City of Fayetteville
Bid 14-35, Retaining Wall Blocks – Materials Only
General Terms and Conditions

1. SUBMISSION OF BID & BID EVALUATION:

- a. Bids shall be reviewed following the stated deadline, as shown on the cover sheet of this document.
- b. Bidders shall submit bids based on documentation published by the Fayetteville Purchasing Division.
- c. Bids shall be enclosed in sealed envelopes or packages addressed to the City of Fayetteville, Purchasing Division, Room 306, 113 W. Mountain, Fayetteville, AR 72701. The name, address of the firm and Bid, RFP, or RFQ number shall be on the outside of the packaging as well as on any packages enclosed in shipping containers or boxes.
- d. The City will not be responsible for misdirected bids. Vendor should call the Purchasing Office at 479.575.8220 to ensure correct receipt of bidding documents prior to opening time and date listed on the bid form.
- e. Bidders must have experience in providing products and/or services of the same or similar nature.
- f. Bidder is advised that exceptions to any of the terms contained in this bid must be identified in its response to the bid. Failure to do so may lead the City to declare any such term non-negotiable. Proposer's desire to take exception to a non-negotiable term will not disqualify it from consideration for award.
- g. Local time is defined as the time in Fayetteville, Arkansas on the due date of the deadline. Bids shall be received before the time as shown by the atomic clock located in the Purchasing Division Office.
- h. Bids will be evaluated and awarded based on the best interest of the City of Fayetteville. The City reserves the right to award bids in their entirety, none, or by line item.

2. WRITTEN REQUESTS FOR INTERPRETATIONS OR CLARIFICATION:

No oral interpretations will be made to any firms as to the meaning of specifications or any other contract documents. All questions pertaining to the terms and conditions or scope of work of this bid must be sent in writing via e-mail to the Purchasing Agent. Responses to questions may be handled as an addendum if the response would provide clarification to the requirements of the bid. All such addenda shall become part of the contract documents. The City will not be responsible for any other explanation or interpretation of the proposed bid made or given prior to the award of the contract.

3. DESCRIPTION OF SUPPLIES AND SERVICES:

Any reference to a particular brand or manufacturer is done in an effort to establish an acceptable level of quality for this project. Brands or manufacturers that are included in bid that are of at least equal quality, size, design, and specification as to what has been specified, will be acceptable for consideration only if approved by the City of Fayetteville Purchasing Division. The City of Fayetteville reserves the right to accept or reject any requested equal.

4. RIGHTS OF CITY OF FAYETTEVILLE BID PROCESS:

In addition to all other rights of the City of Fayetteville, under state law, the City specifically reserves the following:

- a. The City of Fayetteville reserves the right to select the bid that it believes will serve the best interest of the City.
- b. The City of Fayetteville reserves the right to accept or reject any or all bids.
- c. The City of Fayetteville reserves the right to cancel the entire bid.
- d. The City of Fayetteville reserves the right to remedy or waive technical or immaterial errors in the invitation to bid or in bids submitted.
- e. The City of Fayetteville reserves the right to request any necessary clarifications, additional information, or data without changing the terms of the bid.

5. COSTS INCURRED BY BIDDERS:

All expenses involved with the preparation and submission of bids to the City, or any work performed in connection therewith, shall be borne solely by the bidder(s). No payment will be made for any responses received, or for any other effort required of, or made by, the bidder(s) prior to contract commencement.

6. CONFLICT OF INTEREST:

- a. The bidder represents that it presently has no interest and shall acquire no interest, either direct or indirect, which would conflict in any manner with the performance or services required hereunder, as provided in City of Fayetteville Code Section 34.26 titled "Authority of City Employee to Contract With The City".
- b. All bidders shall promptly notify Andrea Foren, City Purchasing Agent, in writing, of all potential conflicts of interest for any prospective business association, interest, or other circumstance which may influence or appear to influence the bidder's judgment or quality of services being provided. Such written notification shall identify the prospective business association, interest or circumstance, the nature of which the bidder may undertake and request an opinion to the City as to whether the association, interest or circumstance would, in the opinion of the City, constitute a conflict of interest if entered into by the bidder. The City agrees to communicate with the bidder its opinion via e-mail or first-class mail within thirty days of receipt of notification.

7. WITHDRAWAL OF PROPOSAL:

A bid may be withdrawn prior to the time set for the bid submittal, based on a written request from an authorized representative of the firm; however, a bid shall not be withdrawn after the time set for the bid unless approved by the Purchasing Division.

8. LATE PROPOSAL OR MODIFICATIONS:

Bid modifications received after the time set for the bid submittal shall not be considered. Modifications in writing received prior to the deadline will be accepted. The City will not be responsible for misdirected bids. Bidders should call the Purchasing Division at (479) 575-8220 to insure receipt of their submittal documents prior to opening time and date listed.

9. LOCAL, STATE, AND FEDERAL COMPLIANCE REQUIREMENTS:

- a. The laws of the State of Arkansas apply to any purchase made under this bid. Bidders shall comply with all local, state, and federal directives, orders and laws as applicable to this proposal and subsequent

contract(s) including but not limited to Equal Employment Opportunity (EEO), Disadvantaged Business Enterprises (DBE), & OSHA as applicable to this contract.

- b. Pursuant to Arkansas Code Annotated §22-9-203 The City of Fayetteville encourages all *qualified* small, minority and women business enterprises to bid on and receive contracts for goods, services, and construction. Also, City of Fayetteville encourages all general contractors to subcontract portions of their contract to *qualified* small, minority and women business enterprises.

10. PROVISION FOR OTHER AGENCIES:

Unless otherwise stipulated by the bidder, the bidder agrees to make available to all Government agencies, departments, municipalities, and counties, the proposal prices submitted in accordance with said proposal terms and conditions therein, should any said governmental entity desire to buy under this proposal. Eligible Users shall mean all state of Arkansas agencies, the legislative and judicial branches, political subdivisions (counties, local district school boards, community colleges, municipalities, counties, or other public agencies or authorities), which may desire to purchase under the terms and conditions of the contract.

11. COLLUSION:

The Proposer, by affixing his or her signature to this proposal, agrees to the following: "bidder certifies that his or her bid is made without previous understanding, agreement, or connection with any person, firm or corporation making a proposal for the same item(s) and/or services and is in all respects fair, without outside control, collusion, fraud, or otherwise illegal action."

12. RIGHT TO AUDIT, FOIA, AND JURISDICITON:

- a. The City of Fayetteville reserves the privilege of auditing a vendor's records as such records relate to purchases between the City and said vendor.
- b. Freedom of Information Act: City contracts and documents prepared while performing City contractual work are subject to the Arkansas Freedom of Information Act. If a Freedom of Information Act request is presented to the City of Fayetteville, the (Contractor) will do everything possible to provide the documents in a prompt and timely manner as prescribed in the Arkansas Freedom of Information Act (A.C.A. §25-19-101 et. seq.). Only legally authorized photocopying costs pursuant to the FOIA may be assessed for this compliance.
- c. Legal jurisdiction to resolve any disputes shall be in Washington County, Arkansas with Arkansas law applying to the case.

13. CITY INDEMNIFICATION:

The successful bidder(s) agrees to indemnify the City and hold it harmless from and against all claims, liability, loss, damage or expense, including but not limited to counsel fees, arising from or by reason of any actual or claimed trademark, patent or copyright infringement or litigation based thereon, with respect to the goods or any part thereof covered by this order, and such obligation shall survive acceptance of the goods and payment thereof by the City.

14. VARIANCE FROM STANDARD TERMS & CONDITIONS:

All standard terms and conditions stated in this request for bid apply to this contract except as specifically stated in the subsequent sections of this document, which take precedence, and should be fully understood by bidders prior to

submitting a proposal on this requirement.

15. ADA REQUIREMENT FOR PUBLIC NOTICES & TRANSLATION:

Persons with disabilities requiring reasonable accommodation to participate in this proceeding/event, should call 479.521.1316 (telecommunications device for the deaf), not later than seven days prior to the deadline. Persons needing translation of this document shall contact the City of Fayetteville, Purchasing Division, immediately.

16. PROCUREMENT POLICY FOR RECYCLED MATERIALS:

The City of Fayetteville wishes to encourage its bidders to use recycled products in fulfilling contractual obligations to the City and that such practices will serve as a model for other public entities and private sector companies.

17. PAYMENTS AND INVOICING:

The bidder must specify in their bid the exact company name and address which must be the same as invoices submitted for payment as a result of award of this bid. Further, the successful bidder is responsible for immediately notifying the Purchasing Division of any company name change, which would cause invoicing to change from the name used at the time of the original bid. Payment will be made within thirty days of invoice received. The City of Fayetteville is very credit worthy and will not pay any interest, fees, or penalty for untimely payments. **Payments can be processed through bidder's acceptance of Visa at no additional costs to the City for expedited payment processing.** The City will not agree to any nonrefundable deposit or retainer that would remain property of the bidder even if the hourly work actually performed by the bidder would not justify such fee.

The City will pay the awarded bidder based on unit prices provided on invoicing. Progress payments will be made after approval and acceptance of work and submission of invoice. Payments will be made within 30 days of accepted invoice.

18. CANCELLATION:

- a. The City reserves the right to cancel this contract without cause by giving thirty (30) days prior notice to the Contractor in writing of the intention to cancel or with cause if at any time the Contractor fails to fulfill or abide by any of the terms or conditions specified.
- b. Failure of the contractor to comply with any of the provisions of the contract shall be considered a material breach of contract and shall be cause for immediate termination of the contract at the discretion of the City of Fayetteville.
- c. In addition to all other legal remedies available to the City of Fayetteville, the City reserves the right to cancel and obtain from another source, any items and/or services which have not been delivered within the period of time from the date of order as determined by the City of Fayetteville.
- d. In the event sufficient budgeted funds are not available for a new fiscal period, the City shall notify the vendor of such occurrence and contract shall terminate of the last day of the current fiscal period without penalty or expense to the City

19. ASSIGNMENT, SUBCONTRACTING, CORPORATE ACQUISITIONS AND/OR MERGERS:

- a. The Contractor shall perform this contract. No assignment of subcontracting shall be allowed without prior written consent of the City. If a bidder intends to subcontract a portion of this work, the bidder shall disclose such intent in the bid submitted as a result of this bid.

- b. In the event of a corporate acquisition and/or merger, the Contractor shall provide written notice to the City within thirty (30) calendar days of Contractor's notice of such action or upon the occurrence of said action, whichever occurs first. The right to terminate this contract, which shall not be unreasonably exercised by the City, shall include, but not be limited to, instances in which a corporate acquisition and/or merger represent a conflict of interest or are contrary to any local, state, or federal laws. Action by the City awarding a proposal to a firm that has disclosed its intent to assign or subcontract in its response to the bid, without exception shall constitute approval for purpose of this Agreement.

20. NON-EXCLUSIVE CONTRACT:

Award of this bid shall impose no obligation on the City to utilize the vendor for all work of this type, which may develop during the contract period. This is not an exclusive contract. The City specifically reserves the right to concurrently contract with other companies for similar work if it deems such an action to be in the City's best interest. In the case of multiple-term contracts, this provision shall apply separately to each item.

21. LOBBYING:

Lobbying of selection committee members, City of Fayetteville employees, or elected officials regarding request for proposals, request for qualifications, bids or contracts, during the pendency of bid protest, by the bidder/proposer/protestor or any member of the bidder's/proposer's/protestor's staff, and agent of the bidder/proposer/protestor, or any person employed by any legal entity affiliated with or representing an organization that is responding to the request for proposal, request for qualification, bid or contract, or has a pending bid protest is strictly prohibited either upon advertisement or on a date established by the City of Fayetteville and shall be prohibited until either an award is final or the protest is finally resolved by the City of Fayetteville; provided, however, nothing herein shall prohibit a prospective/bidder/proposer from contacting the Purchasing Division to address situations such as clarification and/or questions related to the procurement process. For purposes of this provision lobbying activities shall include but not be limited to, influencing or attempting to influence action or non-action in connection with any request for proposal, request for qualification, bid or contract through direct or indirect oral or written communication or an attempt to obtain goodwill of persons and/or entities specified in this provision. Such actions may cause any request for proposal, request for qualification, bid or contract to be rejected.

22. ADDITIONAL REQUIREMENTS:

The City reserves the right to request additional services relating to this bid from the bidder. When approved by the City as an amendment to the contract and authorized in writing prior to work, the Contractor shall provide such additional requirements as may become necessary.

23. ADD OR DELETE LOCATIONS OR SERVICES:

The City reserves the right to unilaterally add or delete locations and/or services, either collectively or individually, at the City's sole option, at any time after award has been made as may be deemed necessary or in the best interests of the City. In such case, the Contractor(s) will be required to provide services to this contract in accordance with the terms, conditions, and specifications.

24. INTEGRITY OF BID DOCUMENTS:

Bidders shall use the original bid form(s) provided by the Purchasing Division and enter information only in the spaces where a response is requested. Bidders may use an attachment as an addendum to the bid form(s) if sufficient space is not available on the original form for the bidder to enter a complete response. **Any modifications or alterations to the**

original documents by the bidder, whether intentional or otherwise, will constitute grounds for rejection of such response. Any such modifications or alterations a bidder wishes to propose shall be clearly stated in the bidder's response and presented in the form of an addendum to the original bid documents.

25. OTHER GENERAL CONDITIONS:

- a) Bidder is presumed to be familiar with all federal, state, and city laws, ordinances, and regulations which in any manner affect those engaged or employed in the Work, or the materials or equipment used, or that in any way affect the Work and shall in all respects comply with said laws, ordinances, and regulations. No claim of misunderstanding or ignorance on the part of Bidder or Proposer will in any way serve to modify the provisions of the contract. No representations shall be binding unless embodied in the contract.
- b) Prices shall include all labor, materials, overhead, profit, insurance, shipping, freight, etc., to cover the products and services presented. ***Sales tax shall not be included in the bid price.*** Applicable Arkansas sales tax laws will apply when necessary but will not be considered in award of this project.
- c) Each bidder should state the anticipated number of days from the date of receipt of an order for delivery of services to the City of Fayetteville.
- d) Bidders must provide the City with their bids signed by an employee having legal authority to submit bids on behalf of the bidder. The entire cost of preparing and providing responses shall be borne by the bidder.
- e) The City reserves the right to request any additional information it deems necessary from any or all bidders after the submission deadline.
- f) The request for bid is not to be construed as an offer, a contract, or a commitment of any kind; nor does it commit the city to pay for any costs incurred by bidder in preparation. It shall be clearly understood that any costs incurred by the Proposer in responding to this request for proposal is at the bidder's own risk and expense as a cost of doing business. The City of Fayetteville shall not be liable for reimbursement to the Proposer for any expense so incurred, regardless of whether or not the proposal is accepted.
- g) If products, components, or services other than those described in this bid document are proposed, the bidder must include complete descriptive literature for each. All requests for additional information must be received within five working days following the request.
- h) NOTE: Any uncertainties shall be brought to the attention to Andrea Foren immediately via telephone (479.575.8220) or e-mail (aforen@fayetteville-ar.gov). It is the intent and goal of the City of Fayetteville Purchasing Division to provide documents providing a clear and accurate understanding of the scope of work to be completed and/or goods to be provided. We encourage all interested parties to ask questions to enable all bidders to be on equal bidding terms.
- i) Any inquiries or requests for explanation in regard to the City's requirements should be made promptly to Andrea Foren, City of Fayetteville, Purchasing Agent via e-mail (aforen@fayetteville-ar.gov) or telephone (479.575.8220). No oral interpretation or clarifications will be given as to the meaning of any part of this request for proposal. All questions, clarifications, and requests, together with answers, if any, will be provided to all firms via written addendum. Names of firms submitting any questions, clarifications, or requests will not be disclosed until after a contract is in place.
- j) Any information provided herein is intended to assist the bidder in the preparation of proposals necessary to properly respond to this bid. The bid is designed to provide qualified Proposers with sufficient basic information

to submit proposals meeting minimum specifications and/or test requirements, but is not intended to limit a bid's content or to exclude any relevant or essential data.

- k) Bidders irrevocably consent that any legal action or proceeding against it under, arising out of or in any manner relating to this Contract shall be prevailed by Arkansas law. Proposer hereby expressly and irrevocably waives any claim or defense in any said action or proceeding based on any alleged lack of jurisdiction or improper venue or any similar basis.
- l) The successful bidder shall not assign the whole or any part of this Contract or any monies due or to become due hereunder without written consent of City of Fayetteville. In case the successful bidder assigns all or any part of any monies due or to become due under this Contract, the Instrument of assignment shall contain a clause substantially to the effect that is agreed that the right of the assignee in and to any monies due or to become due to the successful bidder shall be subject to prior liens of all persons, firms, and corporations for services rendered or materials supplied for the performance of the services called for in this contract.
- m) The successful bidder's attention is directed to the fact that all applicable Federal and State laws, municipal ordinances, and the rules and regulations of all authorities having jurisdiction over the services shall apply to the contract throughout, and they will be deemed to be included in the contract as though written out in full herein. The successful bidder shall keep himself/herself fully informed of all laws, ordinances and regulations of the Federal, State, and municipal governments or authorities in any manner affecting those engaged or employed in providing these services or in any way affecting the conduct of the services and of all orders and decrees of bodies or tribunals having any jurisdiction or authority over same. If any discrepancy or inconsistency should be discovered in these Contract Documents or in the specifications herein referred to, in relation to any such law, ordinance, regulation, order or decree, s/he shall herewith report the same in writing to City of Fayetteville.

City of Fayetteville
Bid 14-35, Retaining Wall Blocks – Materials Only
Technical Specification: Wall Units shall be Redi-Rock® 28" Series Wall System or Equal

1. GENERAL –

- a. Bid prices shall **exclude** applicable taxes; however, sales tax will apply to all orders in accordance with local, state, and federal law. Pricing shall be inclusive of materials, shipping, fuel, etc.
- b. All materials shall be shipped to a single job site in Fayetteville, Arkansas. Vendor shall coordinate with City of Fayetteville in regards to final destination ship point within the City limits of Fayetteville, AR.
- c. The City of Fayetteville reserves the right to award bids all or none. The City of Fayetteville also reserves the right to deviate from estimated purchase quantities.
- d. The City of Fayetteville intends to purchase all blocks shown on the bid form for a single job, placed in a single order, and delivered as coordinated and scheduled with the City Transportation Division. Delivery for materials shall occur in the following manner:
 - i. Not all materials will be delivered on the same day; however, all interested parties shall understand these materials are for the intended use of a single project and deliveries may occur over a 14 calendar day time period.
 - ii. Delivery schedule for all items shall be coordinated with the City of Fayetteville Transportation Division within five (5) calendar days of order being placed, unless longer time is needed by the City.
 - iii. Deliveries shall be made in full semi-truck loads, with the exception of the final delivery.
 - iv. First shipment shall arrive for delivery within ten (10) calendar days of order being placed, followed by additional subsequent truck deliveries as scheduled with the City. The City anticipates 1-2 full truck loads per day over a consecutive fourteen (14) calendar day time period.
 - v. The City reserves the right to purchase additional quantities as needed through 12/31/2014. Bidders shall hold pricing firm through 12/31/14.
 - vi. The City of Fayetteville shall be responsible for offloading materials at the job site.

2. MATERIALS –

- a. Wall units shall be Redi-Rock® as produced by a licensed manufacturer or equal.
- b. Wall units shall be made with ready-mixed concrete in accordance with ASTM C94, latest revision, and per the following chart: **Higher slumps are allowed if achieved by use of*

appropriate admixtures.

CLIMATE	AIR CONTENT	28 Day Compressive Strength, PSI	SLUMP*
Negligible	1 ½% - 4 ½%	3,000	5" +/- 1 ½"
Moderate	3% - 6%	3,000	5" +/- 1 ½"
Severe	4 ½% - 7 ½%	3,000	5" +/- 1 ½"

- c. Notwithstanding anything stated above, all materials used in the wall units must meet applicable ASTM and local requirements for exterior concrete.
- d. Exterior block dimensions shall be uniform and consistent. Maximum dimensional deviations shall be 1%, excluding the architectural surface. Maximum width (face to back) deviation including the architectural surface shall be 1.0 inch.
- e. Exposed face shall be Cobble Stone finish. Other surfaces to be smooth form type. Dime-size bug holes on the block face may be patched and/or shake-on color stain can be used to blend into the remainder of block face.

3. TECHNICAL SPECIFICATIONS

41" Series Blocks

Top - 28"

Volume = 8.55 cft
 Weight = ±1223 lbs
 C of G = 15.06"

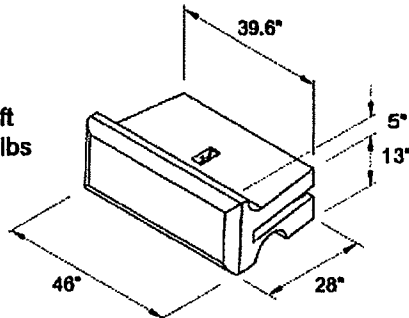

Half Top - 28"

Volume = 4.13 cft
 Weight = ±591 lbs

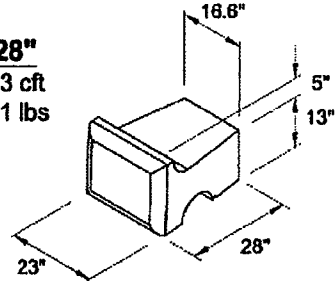

Middle - 41"

Volume = 16.44 cft
 Weight = ±2351 lbs
 C of G = 20.92"

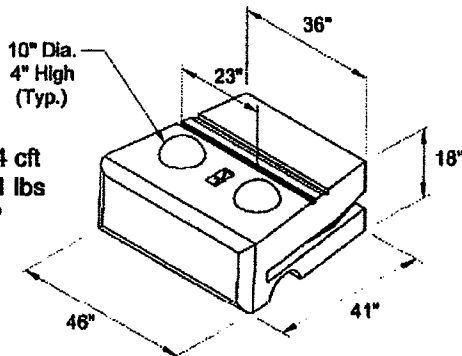

Half Middle - 41"

Volume = 7.28 cft
 Weight = ±1041 lbs

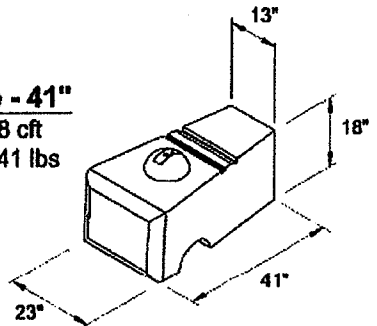

Bottom - 41"

Volume = 17.37 cft
 Weight = ±2483 lbs
 C of G = 21.3"

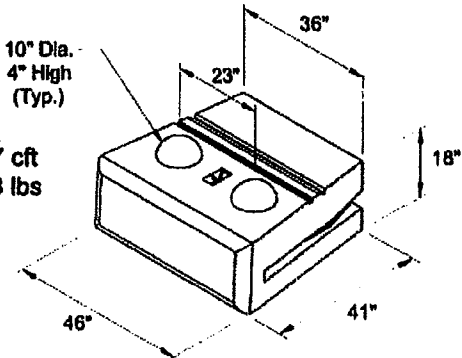

Half Bottom - 41"

Volume = 7.73 cft
 Weight = ±1105 lbs

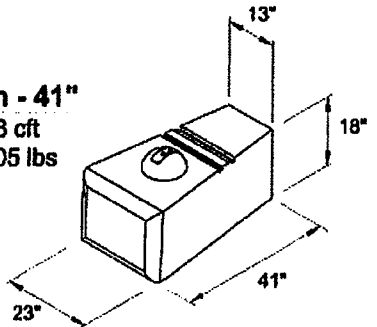

Planter

Volume = 14.12 cft
 Weight = ±2020 lbs
 C of G = 19.35"

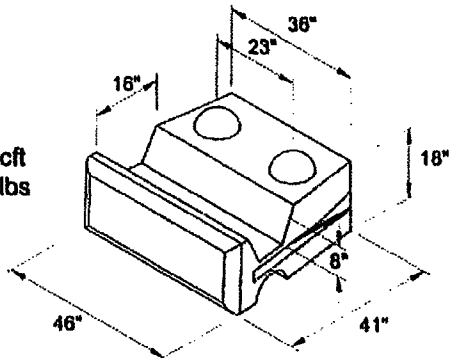

Half Planter

Volume = 5.91 cft
 Weight = ±890 lbs

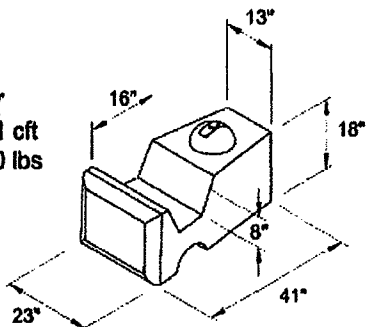

28" Series Blocks

Top - 28"

Volume = 8.55 cft
 Weight = ±1223 lbs
 C of G = 15.06"

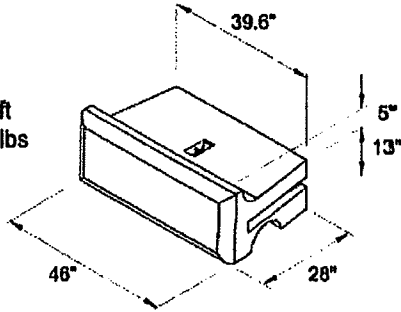

Half Top - 28"

Volume = 4.13 cft
 Weight = ±591 lbs

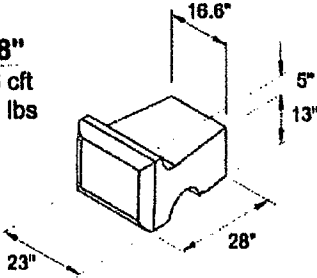

Middle - 28"

Volume = 11.40 cft
 Weight = ±1630 lbs
 C of G = 14.18"

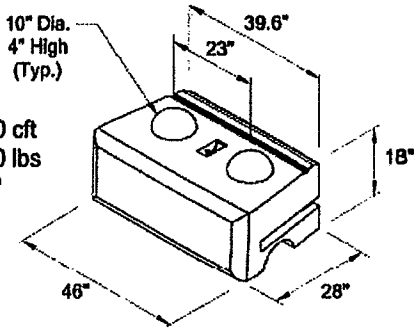

Half Middle - 28"

Volume = 5.34 cft
 Weight = ±764 lbs

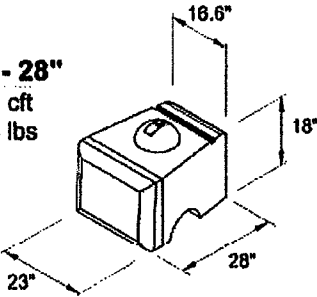

Bottom - 28"

Volume = 12.36 cft
 Weight = ±1768 lbs
 C of G = 14.23"

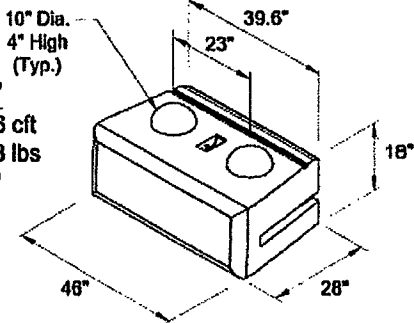

Half Bottom - 28"

Volume = 5.79 cft
 Weight = ±827 lbs

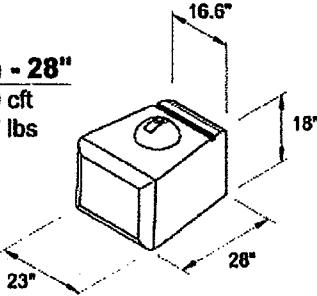

23" End Block

Volume = 6.79 cft
 Weight = ± 970 lbs
 C of G = 12.29"

