

City of Fayetteville Item Review Form

2014-0185

Legistar File Number

May 6, 2014

City Council Meeting Date - Agenda Item Only  
N/A for Non-Agenda Item

Matt Mihalevich

Submitted By

Development Services

Department

Action Required:

Staff requests approval of the purchase of 52 LED trail light fixtures from First Light of Tulsa in the amount of \$87,048.00 plus sales tax of \$8,487.18 and the purchase of 52 light poles from Whatley, Inc. in the amount of \$29,744.00 plus sales tax of \$2,900.04 for a total purchase of \$128,179.22 using bid #14-23 for installation along the Tsa La Gi Trail.

Does this item have a cost?  Yes

\$128,179.22

Cost of this request

\$409,520.00

Category or Project Budget

Tsa La Gi Trail

Program or Project Name

4470.9470.5814.05

Account Number

\$60,560.82

Funds Used to Date

Trail Development

Program or Project Category

02016.1203

Project Number

\$220,779.96

Remaining Balance

Sales Tax Capital Imp

Fund Name

Budgeted Item?  Yes

Budget Adjustment Attached?  No

V20130812

Previous Ordinance or Resolution # \_\_\_\_\_

Original Contract Number: \_\_\_\_\_

Comments:

 4/21/14

Paul a. Barber 4-21-2014

Ann Man 4-22-14





## CITY COUNCIL AGENDA MEMO

### MEETING OF MAY 6<sup>TH</sup> 2014

**TO:** Mayor and City Council

**THRU:** Don Marr, Chief of Staff  
Jeremy Pate, Development Services Director  
Chris Brown, City Engineer

**FROM:** Matt Mihalevich, Trails Coordinator

**DATE:** April 18<sup>th</sup>, 2014

**SUBJECT:** Tsa La Gi Trail lighting purchase award

---

#### RECOMMENDATION:

Approval of the purchase of 52 LED trail light fixtures from First Light of Tulsa in the amount of \$87,048.00 plus sales tax of \$8,487.18 and the purchase of 52 light poles from Whatley, Inc. in the amount of \$29,744.00 plus sales tax of \$2,900.04 for a total purchase of \$128,179.22 using bid #14-23 for installation along the Tsa La Gi Trail.

#### BACKGROUND:

The City in-house trail construction crew is nearing completion of a 1.4 mile long section of the Tsa La Gi (Cherokee) Trail that runs along the south side of MLK Jr. Blvd and will soon connect to the newly completed Frisco Trail southern extension near Government Ave. Electrical conduit has been installed along the trail in preparation for lighting along this new trail.

#### DISCUSSION:

These light fixtures and poles will match the standard black fixture seen along most of Scull Creek Trail and include the energy efficiency and reduced maintenance advantage of LED (Light Emitting Diode) light source while providing excellent light coverage for the trail.

#### BUDGET/STAFF IMPACT:

Eight bidders responded to the request for formal bids, First Light of Tulsa was low bidder for the light fixtures and Whatley, Inc was the low bidder for the poles – see attached bid tabulation. Funding in the amount of \$128,179.22 has been budget through the Trail Development Capital Improvement Program.

#### Attachments:

Staff Review Form  
Bid 14-23, Trail Lighting – Equipment Only Bid summary  
First Light of Tulsa - Purchase Requisition  
Whatley, Inc – Purchase Requisition

**RESOLUTION NO. \_\_\_\_\_**

A RESOLUTION TO AUTHORIZE THE PURCHASE OF LED TRAIL LIGHT FIXTURES FROM FIRST LIGHT OF TULSA IN THE AMOUNT OF \$87,048.00 PLUS APPLICABLE SALES TAX, AND TO AUTHORIZE THE PURCHASE OF LIGHT POLES FROM WHATLEY, INC. IN THE AMOUNT OF \$29,744.00 PLUS APPLICABLE SALES TAX, PURSUANT TO BID #14-23, FOR INSTALLATION ALONG THE TSA LA GI TRAIL

**BE IT RESOLVED BY THE CITY COUNCIL OF THE CITY OF FAYETTEVILLE, ARKANSAS:**

Section 1. That the City Council of the City of Fayetteville, Arkansas hereby authorizes the purchase of fifty-two (52) LED light fixtures from First Light of Tulsa in the amount of \$87,048.00 plus applicable sales tax, pursuant to Bid #14-23, for installation along the Tsa La Gi Trail.

Section 2. That the City Council of the City of Fayetteville, Arkansas authorizes the purchase of fifty-two (52) light poles from Whatley, Inc. in the amount of \$29,744.00 plus applicable sales tax, pursuant to Bid #14-23, for installation along the Tsa La Gi Trail.

**PASSED and APPROVED** this 6<sup>th</sup> day of May, 2014.

APPROVED:

ATTEST:

By: \_\_\_\_\_  
**LIONELD JORDAN**, Mayor

By: \_\_\_\_\_  
**SONDRA E. SMITH**, City Clerk/Treasurer

**TSA LA GI TRAIL - 1.4 Miles Long  
Blue Sections to Recieve Lighting  
Open Late Spring 2014**

**Existing Frisco Trail  
& Razorback Greenway  
36 Miles to Bentonville**

**Tsa La Gi Trail - Lighting**

- Legend**
- Tsa La Gi Trail
  - - - Future Trails
  - Existing Multi-Use Trail

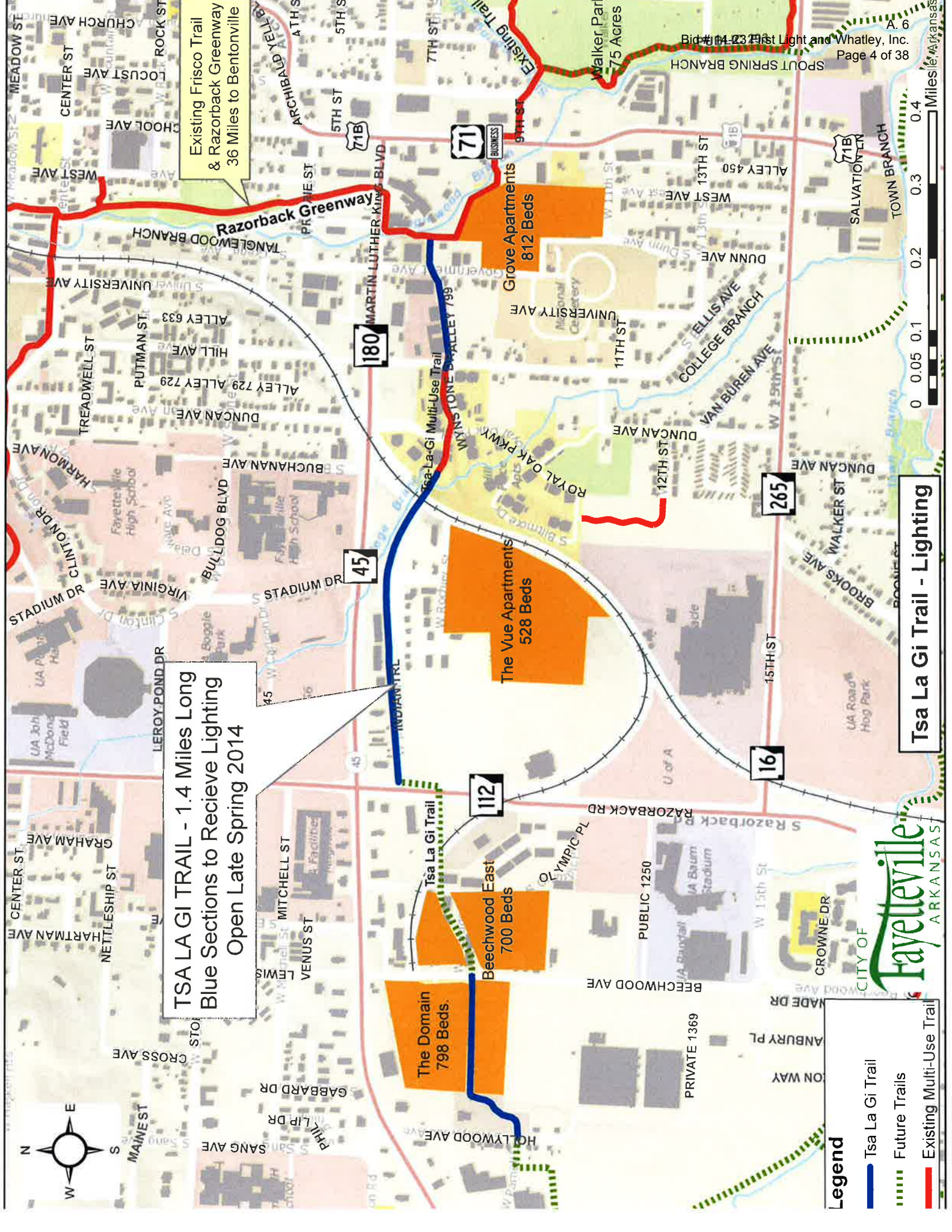

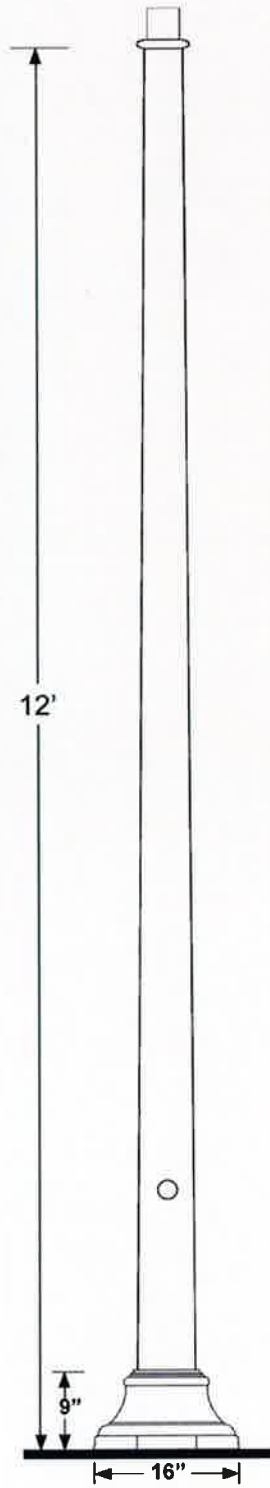



BID: 14-23  
4/3/2014  
2:00 PM  
CITY OF FAYETTEVILLE

# Bid 14-23, Trail Lighting - Equipment Only

BIDDER	Quantity	Luminaire Each	Luminaire Total	Pole Each	Pole Total	TOTAL BID PRICE
1 BA Supply	52	\$ 2,203.28 \$ Amerlux: PT40/DPM-3/T3-5L/BLK	114,570.56	\$ 670.52 \$ American Composite: DS15ASDS-JXB	\$ 34,867.04	\$ 149,437.60
2 Consolidated Electrical Distributor	52	\$ 2,095.00 \$ Amerlux: PT40/DPM-3/T3-5L/BLK	108,940.00	\$ 636.00 \$ ACI: DS15ASDS-JXB	\$ 33,072.00	\$ 142,012.00
3 Elliott Electric Supply, Inc.	52	\$ 2,037.00 \$ Amerlux: PT40/DPM-3/T3-5L/BLK	105,924.00	\$ 620.00 \$ ACI: DS15ASDS-JXB	\$ 32,240.00	\$ 138,164.00
4 First Light of Tulsa	52	\$ 1,674.00 \$ Amerlux: PT40/DPM-3M/LED-H3-5.0K-6.5L-100W/BLK	87,048.00	- \$ NO BID	-	\$ 87,048.00 Bid Luminaire Only
5 Graybar	52	\$ 1,925.00 \$ Amerlux: PT40/DPM-3/T3-5L/BLK	100,100.00	\$ 575.00 \$ Alliance Composites: DS15ASDS-JXB	\$ 29,900.00	\$ 130,000.00
6 Upchurch Electrical Supply Company	52	\$ 2,007.00 \$ Amerlux: PT40/DPM-3/T3-5L/BLK 5K:6000LM; 82W; Type III Slip fits over 4" tenon	104,364.00	\$ 610.00 \$ Alliance Composites: DS15ASDS-JXB	\$ 31,720.00	\$ 136,084.00
7 Whatley, Inc.	52	- \$ NO BID	-	\$ 572.00 \$ Whatley Inc.: ST45-D10M-OCE12.DE-STD-40-XX	\$ 29,744.00	\$ 29,744.00 Bid Pole Only
8 Wholesale Electric Supply	52	\$ 1,881.78 \$ Amerlux: PT40/DPM-3/T3-5L/BLK	97,852.56	\$ 573.70 \$ ACI: DS15ASDS-JXB	\$ 29,832.40	\$ 127,684.96

\*NOTICE: Bid award is contingent upon vendor meeting minimum specifications and formal authorization by City officials.

CERTIFIED: P. Vice      A. Zorn      4/03/14  
P. VICE, Purchasing MGR      WITNESS      DATE



City of Fayetteville, Arkansas  
Purchasing Division – Room 306  
113 W. Mountain  
Fayetteville, AR 72701  
Phone: 479.575.8220  
TDD (Telecommunication Device for the Deaf): 479.521.1316

**INVITATION TO BID**

**INVITATION TO BID: Bid 14-23, Trail Lighting – Equipment Only**  
**DEADLINE: Thursday, April 03, 2014 before 2:00 PM, Local Time**  
**DELIVERY LOCATION: Room 306 – 113 W. Mountain, Fayetteville, AR 72701**  
**PURCHASING AGENT: Andrea Foren, CPPO, CPPB, [aforen@fayetteville-ar.gov](mailto:aforen@fayetteville-ar.gov)**  
**DATE OF ISSUE AND ADVERTISEMENT: Friday, March 14, 2014**

**INVITATION TO BID**  
**Bid 14-23, Trail Lighting – Equipment Only**

No late bids will be accepted. Bids shall be submitted in sealed envelopes labeled with the name and address of the bidder.

All bids shall be submitted in accordance with the attached City of Fayetteville specifications and bid documents attached hereto. Each bidder is required to fill in every blank and shall supply all information requested; failure to do so may be used as basis of rejection.

The undersigned hereby offers to furnish & deliver the articles or services as specified, at the prices & terms stated herein, and in strict accordance with the specifications and general conditions of bidding, all of which are made a part of this offer. This offer is not subject to withdrawal unless upon mutual written agreement by the Proposer/Bidder and City Purchasing Manager.

Name of Firm: First Light of Tulsa  
Contact Person: Clete Harrington Title: District Manager  
E-Mail: charrington@firstlightsystems.com Phone: 918-627-5483  
Business Address: 5003 S. 101st E. Ave.  
City: Tulsa State: OK Zip: 74146  
Signature:  Date: 3-28-2014

**City of Fayetteville**  
**Bid 14-23, Trail Lighting – Equipment Only**  
**Bid Form**

**DATE REQUIRED AS A COMPLETE UNIT: Delivery shall be made within 12 weeks from date of received Purchase Order.**

**F.O.B. Transportation Division, 1455 S. Happy Hollow Rd., Fayetteville, AR 72701**

Item	Description	Initial Estimated Quantity		Price Per Each	Total Line Item Price
1	<b>Luminaire:</b> Model #PT40 / DPM-3M / LED-H3-5.0K-6.5L-100W / BLK - Flat Polycarbonate lens <u>or</u> LEXAN, Type III, Full Cutoff made by Amerlux Exterior or approved equal as determined by the City of Fayetteville.	52	x	\$ <u>1,674.00</u>	= \$ <u>87,048.00</u>
Please Specify for Unit(s) Bid for Item #1:					
*MANUFACTURER: <u>Amerlux</u> *MODEL: <u>PT40/DPM-3M/LED-H3-5.0K-6.5L-100W/BLK (AS SPECIFIED)</u>					
2	<b>Pole:</b> Direct Bury 12' Composite Materials Technology (CMT) Legacy fiberglass pole black with decorative base, Model #LFY12-T-3-T400X4.5-S with 4" O.D. tenon <u>or</u> Alliance Composites DS15ASDS4-JXB, or other approved equal as determined by the City of Fayetteville.	52	x	\$ <u>No Quote</u>	= \$ <u>No Quote</u>
Please Specify for Unit(s) Bid for Item #2:					
*MANUFACTURER: <u>No Quote</u> *MODEL: <u>No Quote</u>					
<u>Bidding Item 1 only CH</u>					<b>*TOTAL BASE BID:</b>
*Total Base Bid shall be the calculated sum of items 1 and 2. Each line item shall be calculated by multiplying the Quantity times Price per Each. Price Per Each shall be inclusive of the item, freight, shipping, etc.					\$ <u>87,048.00</u>

Bids must be submitted on this bid form in its entirety AND accompanied by descriptive literature on the products being bid.

**THIS BID FORM CONTINUES ON THE NEXT PAGE.**



**EXECUTION OF BID -**

**Actual specification of any deficient item shall be noted on the bid sheet or separate attachment. If specifications of item bid differ from provided literature, deviation shall be documented and certified by the manufacturer as a regular production option.**

**Upon signing this Bid, the bidder certifies that:**

1. He/she has read and agrees to the requirements set forth in this proposal, including specifications, terms, standard conditions, and any pertinent information regarding the articles being bid on.
2. Unless otherwise noted and explained, the unit bid and listed meets or exceeds all of these requirements as specified by The City of Fayetteville.
3. The Bidder can and will comply with all specifications and requirements for delivery, documentation and support as specified herein.
4. I, as an officer of this organization, or per the attached letter of authorization, am duly authorized to certify the information provided herein is accurate and true.
5. Bidder shall comply with all State and Federal Equal Opportunity and Non-Discrimination requirements and conditions of employment in addition to all federal, state, and local laws.
6. Bidder shall disclose any possible conflict of interest with the City of Fayetteville, including, but not limited to, any relationship with any City of Fayetteville employee. Response shall disclose if a known relationship exists between any principal or employee of your firm and any City of Fayetteville employee or elected City of Fayetteville official. If no relationship exists, this should also be stated in your response. Failure to disclose such a relationship may result in cancellation of a purchase and/or contract as a result of your response.

CH 1.) NO KNOWN RELATIONSHIP EXISTS

\_\_\_\_\_ 2.) RELATIONSHIP EXISTS (Please explain): \_\_\_\_\_

7. Bidder will perform the Work in compliance with all applicable trench safety standards set forth in Occupational Safety and Health Administration (OSHA) Part 1926 – Subpart P – Excavations.
8. As A bidder on this project, you are required to provide debarment/suspension certification indicating that you are in compliance with the below Federal Executive Order. Certification can be done by completing and signing this form.
  - a. Federal Executive Order (E.O.) 12549 "Debarment and Suspension" requires that all contractors receiving individual awards, using federal funds, and all sub-recipients certify that the organization and its principals are not debarred, suspended, proposed for debarment, declared ineligible, or voluntarily excluded by any Federal department or agency from doing business with the Federal Government.
  - b. Your signature below certifies that neither you nor your principal is presently debarred, suspended, proposed for debarment, declared ineligible, or voluntarily excluded from participation in this transaction by any federal department or agency.

Unsigned bids will be rejected. Items marked \* are mandatory for consideration.

\*NAME OF FIRM: First Light of Tulsa

\*D/B/A or Corporation Name Purchase Order/Payments shall be issued to this name  
Robinson Electric Supply Co., Inc.

\*BUSINESS ADDRESS: 5003 S. 101<sup>st</sup> E. Ave.

\*CITY: Tulsa \*STATE: OK \*ZIP: 74146

\*PHONE: 918-627-5483 FAX: 918-610-5483

\*E-MAIL: charrington@firstlightsystems.com

\*BY: (PRINTED NAME) Clete Harrington

\*AUTHORIZED SIGNATURE: 

\*TITLE: Division Manager

\*DUNS NUMBER: 07-764-9994 CAGE NUMBER: \_\_\_\_\_

\*TAX ID NUMBER: 64-0568579

Acknowledge Addendums:

Addendum No. \_\_\_\_\_ Dated: \_\_\_\_\_ Acknowledged by: \_\_\_\_\_

Addendum No. \_\_\_\_\_ Dated: \_\_\_\_\_ Acknowledged by: \_\_\_\_\_

Addendum No. \_\_\_\_\_ Dated: \_\_\_\_\_ Acknowledged by: \_\_\_\_\_

## **City of Fayetteville Bid 14-23, Trail Lighting – Equipment Only General Terms and Conditions**

---

### **1. SUBMISSION OF BID & BID EVALUATION:**

- a. Bids shall be reviewed following the stated deadline, as shown on the cover sheet of this document.
- b. Bidders shall submit bids based on documentation published by the Fayetteville Purchasing Division.
- c. Bids shall be enclosed in sealed envelopes or packages addressed to the City of Fayetteville, Purchasing Division, Room 306, 113 W. Mountain, Fayetteville, AR 72701. The name, address of the firm and Bid, RFP, or RFQ number shall be on the outside of the packaging as well as on any packages enclosed in shipping containers or boxes.
- d. The City will not be responsible for misdirected bids. Vendor should call the Purchasing Office at 479.575.8220 to ensure correct receipt of bidding documents prior to opening time and date listed on the bid form.
- e. Bidders must have experience in providing products and/or services of the same or similar nature.
- f. Bidder is advised that exceptions to any of the terms contained in this bid must be identified in this response to the bid. Failure to do so may lead the City to declare any such term non-negotiable. Proposer's desire to take exception to a non-negotiable term will not disqualify it from consideration for award.
- g. Local time is defined as the time in Fayetteville, Arkansas on the due date of the deadline. Bids shall be received before the time as shown by the atomic clock located in the Purchasing Division Office.
- h. Bids will be evaluated and awarded based on the best interest of the City of Fayetteville. The City reserves the right to award bids in their entirety, none, or by line item.

### **2. WRITTEN REQUESTS FOR INTERPRETATIONS OR CLARIFICATION:**

No oral interpretations will be made to any firms as to the meaning of specifications or any other contract documents. All questions pertaining to the terms and conditions or scope of work of this bid must be sent in writing via e-mail to the Purchasing Agent. Responses to questions may be handled as an addendum if the response would provide clarification to the requirements of the bid. All such addenda shall become part of the contract documents. The City will not be responsible for any other explanation or interpretation of the proposed bid made or given prior to the award of the contract.

### **3. DESCRIPTION OF SUPPLIES AND SERVICES:**

Any reference to a particular brand or manufacturer is done in an effort to establish an acceptable level of quality for this project. Brands or manufacturers that are included in bid that are of at least equal quality, size, design, and specification as to what has been specified, will be acceptable for consideration only if approved by the City of Fayetteville Purchasing Division. The City of Fayetteville reserves the right to accept or reject any requested equal.

### **4. RIGHTS OF CITY OF FAYETTEVILLE BID PROCESS:**

In addition to all other rights of the City of Fayetteville, under state law, the City specifically reserves the following:

- a. The City of Fayetteville reserves the right to select the bid that it believes will serve the best interest of the City.
- b. The City of Fayetteville reserves the right to accept or reject any or all bids.
- c. The City of Fayetteville reserves the right to cancel the entire bid.
- d. The City of Fayetteville reserves the right to remedy or waive technical or immaterial errors in the invitation to bid or in bids submitted.

- e. The City of Fayetteville reserves the right to request any necessary clarifications, additional information, or data without changing the terms of the bid.

**5. COSTS INCURRED BY BIDDERS:**

All expenses involved with the preparation and submission of bids to the City, or any work performed in connection therewith, shall be borne solely by the bidder(s). No payment will be made for any responses received, or for any other effort required of, or made by, the bidder(s) prior to contract commencement.

**6. CONFLICT OF INTEREST:**

- a. The bidder represents that it presently has no interest and shall acquire no interest, either direct or indirect, which would conflict in any manner with the performance or services required hereunder, as provided in City of Fayetteville Code Section 34.26 titled "Authority of City Employee to Contract With The City".
- b. All bidders shall promptly notify Andrea Foren, City Purchasing Agent, in writing, of all potential conflicts of interest for any prospective business association, interest, or other circumstance which may influence or appear to influence the bidder's judgment or quality of services being provided. Such written notification shall identify the prospective business association, interest or circumstance, the nature of which the bidder may undertake and request an opinion to the City as to whether the association, interest or circumstance would, in the opinion of the City, constitute a conflict of interest if entered into by the bidder. The City agrees to communicate with the bidder its opinion via e-mail or first-class mail within thirty days of receipt of notification.

**7. WITHDRAWAL OF PROPOSAL:**

A bid may be withdrawn prior to the time set for the bid submittal, based on a written request from an authorized representative of the firm; however, a bid shall not be withdrawn after the time set for the bid unless approved by the Purchasing Division.

**8. LATE PROPOSAL OR MODIFICATIONS:**

1. Bid modifications received after the time set for the bid submittal shall not be considered. Modifications in writing received prior to the deadline will be accepted. The City will not be responsible for misdirected bids. Bidders should call the Purchasing Division at (479) 575-8220 to insure receipt of their submittal documents prior to opening time and date listed.

**9. LOCAL, STATE, AND FEDERAL COMPLIANCE REQUIREMENTS:**

- a. The laws of the State of Arkansas apply to any purchase made under this bid. Bidders shall comply with all local, state, and federal directives, orders and laws as applicable to this proposal and subsequent contract(s) including but not limited to Equal Employment Opportunity (EEO), Disadvantaged Business Enterprises (DBE), & OSHA as applicable to this contract.
- b. Pursuant to Arkansas Code Annotated §22-9-203 The City of Fayetteville encourages all *qualified* small, minority and women business enterprises to bid on and receive contracts for goods, services, and construction. Also, City of Fayetteville encourages all general contractors to subcontract portions of their contract to *qualified* small, minority and women business enterprises.

**10. PROVISION FOR OTHER AGENCIES:**

Unless otherwise stipulated by the bidder, the bidder agrees to make available to all Government agencies, departments, municipalities, and counties, the proposal prices submitted in accordance with said proposal terms and conditions therein, should any said governmental entity desire to buy under this proposal. Eligible Users shall mean all state of Arkansas agencies, the legislative and judicial branches, political subdivisions (counties, local district school boards, community colleges, municipalities, counties, or other public agencies or authorities), which may desire to purchase under the terms and conditions of the contract.

**11. COLLUSION:**

The Proposer, by affixing his or her signature to this proposal, agrees to the following: "bidder certifies that his or her bid is made without previous understanding, agreement, or connection with any person, firm or corporation making a proposal for the same item(s) and/or services and is in all respects fair, without outside control, collusion, fraud, or otherwise illegal action."

**12. RIGHT TO AUDIT, FOIA, AND JURISDICITON:**

- a. The City of Fayetteville reserves the privilege of auditing a vendor's records as such records relate to purchases between the City and said vendor.
- b. Freedom of Information Act: City contracts and documents prepared while performing City contractual work are subject to the Arkansas Freedom of Information Act. If a Freedom of Information Act request is presented to the City of Fayetteville, the (Contractor) will do everything possible to provide the documents in a prompt and timely manner as prescribed in the Arkansas Freedom of Information Act (A.C.A. §25-19-101 et. seq.). Only legally authorized photocopying costs pursuant to the FOIA may be assessed for this compliance.
- c. Legal jurisdiction to resolve any disputes shall be in Washington County, Arkansas with Arkansas law applying to the case.

**13. CITY INDEMNIFICATION:**

The successful bidder(s) agrees to indemnify the City and hold it harmless from and against all claims, liability, loss, damage or expense, including but not limited to counsel fees, arising from or by reason of any actual or claimed trademark, patent or copyright infringement or litigation based thereon, with respect to the goods or any part thereof covered by this order, and such obligation shall survive acceptance of the goods and payment thereof by the City.

**14. VARIANCE FROM STANDARD TERMS & CONDITIONS:**

All standard terms and conditions stated in this request for bid apply to this contract except as specifically stated in the subsequent sections of this document, which take precedence, and should be fully understood by bidders prior to submitting a proposal on this requirement.

**15. ADA REQUIREMENT FOR PUBLIC NOTICES & TRANSLATION:**

Persons with disabilities requiring reasonable accommodation to participate in this proceeding/event, should call 479.521.1316 (telecommunications device for the deaf), not later than seven days prior to the deadline. Persons needing translation of this document shall contact the City of Fayetteville, Purchasing Division, immediately.

**16. PROCUREMENT POLICY FOR RECYCLED MATERIALS:**

The City of Fayetteville wishes to encourage its bidders to use recycled products in fulfilling contractual obligations to the City and that such practices will serve as a model for other public entities and private sector companies.

**17. PAYMENTS AND INVOICING:**

The bidder must specify in their bid the exact company name and address which must be the same as invoices submitted for payment as a result of award of this bid. Further, the successful bidder is responsible for immediately notifying the Purchasing Division of any company name change, which would cause invoicing to change from the name used at the time of the original bid. Payment will be made within thirty days of invoice received. The City of Fayetteville is very credit worthy and will not pay any interest, fees, or penalty for untimely payments. **Payments can be processed through bidder's acceptance of Visa at no additional costs to the City for expedited payment processing.** The City will not agree to any nonrefundable deposit or retainer that would remain property of the bidder even if the hourly work actually performed by the bidder would not justify such fee.

The City will pay the awarded bidder based on unit prices provided on invoicing. Progress payments will be made after

approval and acceptance of work and submission of invoice. Payments will be made within 30 days of accepted invoice.

**18. CANCELLATION:**

- a. The City reserves the right to cancel this contract without cause by giving thirty (30) days prior notice to the Contractor in writing of the intention to cancel or with cause if at any time the Contractor fails to fulfill or abide by any of the terms or conditions specified.
- b. Failure of the contractor to comply with any of the provisions of the contract shall be considered a material breach of contract and shall be cause for immediate termination of the contract at the discretion of the City of Fayetteville.
- c. In addition to all other legal remedies available to the City of Fayetteville, the City reserves the right to cancel and obtain from another source, any items and/or services which have not been delivered within the period of time from the date of order as determined by the City of Fayetteville.
- d. In the event sufficient budgeted funds are not available for a new fiscal period, the City shall notify the vendor of such occurrence and contract shall terminate of the last day of the current fiscal period without penalty or expense to the City

**19. ASSIGNMENT, SUBCONTRACTING, CORPORATE ACQUISITIONS AND/OR MERGERS:**

- a. The Contractor shall perform this contract. No assignment of subcontracting shall be allowed without prior written consent of the City. If a bidder intends to subcontract a portion of this work, the bidder shall disclose such intent in the bid submitted as a result of this bid.
- b. In the event of a corporate acquisition and/or merger, the Contractor shall provide written notice to the City within thirty (30) calendar days of Contractor's notice of such action or upon the occurrence of said action, whichever occurs first. The right to terminate this contract, which shall not be unreasonably exercised by the City, shall include, but not be limited to, instances in which a corporate acquisition and/or merger represent a conflict of interest or are contrary to any local, state, or federal laws. Action by the City awarding a proposal to a firm that has disclosed its intent to assign or subcontract in its response to the bid, without exception shall constitute approval for purpose of this Agreement.

**20. NON-EXCLUSIVE CONTRACT:**

Award of this bid shall impose no obligation on the City to utilize the vendor for all work of this type, which may develop during the contract period. This is not an exclusive contract. The City specifically reserves the right to concurrently contract with other companies for similar work if it deems such an action to be in the City's best interest. In the case of multiple-term contracts, this provision shall apply separately to each item.

**21. LOBBYING:**

Lobbying of selection committee members, City of Fayetteville employees, or elected officials regarding request for proposals, request for qualifications, bids or contracts, during the pendency of bid protest, by the bidder/proposer/protestor or any member of the bidder's/proposer's/protestor's staff, and agent of the bidder/proposer/protestor, or any person employed by any legal entity affiliated with or representing an organization that is responding to the request for proposal, request for qualification, bid or contract, or has a pending bid protest is strictly prohibited either upon advertisement or on a date established by the City of Fayetteville and shall be prohibited until either an award is final or the protest is finally resolved by the City of Fayetteville; provided, however, nothing herein shall prohibit a prospective/bidder/proposer from contacting the Purchasing Division to address situations such as clarification and/or questions related to the procurement process. For purposes of this provision lobbying activities shall include but not be limited to, influencing or attempting to influence action or non-action in connection with any request for proposal, request for qualification, bid or contract through direct or indirect oral or written communication or an attempt to obtain goodwill of persons and/or entities specified in this provision. Such actions may cause any request for proposal, request for qualification, bid or contract to be rejected.

**22. ADDITIONAL REQUIREMENTS:**

The City reserves the right to request additional services relating to this bid from the bidder. When approved by the City as an amendment to the contract and authorized in writing prior to work, the Contractor shall provide such additional requirements as may become necessary.

**23. ADD OR DELETE LOCATIONS OR SERVICES:**

The City reserves the right to unilaterally add or delete locations and/or services, either collectively or individually, at the City's sole option, at any time after award has been made as may be deemed necessary or in the best interests of the City. In such case, the Contractor(s) will be required to provide services to this contract in accordance with the terms, conditions, and specifications.

**24. INTEGRITY OF BID DOCUMENTS:**

Bidders shall use the original bid form(s) provided by the Purchasing Division and enter information only in the spaces where a response is requested. Bidders may use an attachment as an addendum to the bid form(s) if sufficient space is not available on the original form for the bidder to enter a complete response. **Any modifications or alterations to the original documents by the bidder, whether intentional or otherwise, will constitute grounds for rejection of such response.** Any such modifications or alterations a bidder wishes to propose shall be clearly stated in the bidder's response and presented in the form of an addendum to the original bid documents.

**25. OTHER GENERAL CONDITIONS:**

- a) Bidder is presumed to be familiar with all federal, state, and city laws, ordinances, and regulations which in any manner affect those engaged or employed in the Work, or the materials or equipment used, or that in any way affect the Work and shall in all respects comply with said laws, ordinances, and regulations. No claim of misunderstanding or ignorance on the part of Bidder or Proposer will in any way serve to modify the provisions of the contract. No representations shall be binding unless embodied in the contract.
- b) Prices shall include all labor, materials, overhead, profit, insurance, shipping, freight, etc., to cover the products and services presented. ***Sales tax is not to be included in the bid price.*** Applicable Arkansas sales tax laws will apply when necessary but will not be considered in award of this project.
- c) Each bidder should state the anticipated number of days from the date of receipt of an order for delivery of services to the City of Fayetteville.
- d) Bidders must provide the City with their bids signed by an employee having legal authority to submit bids on behalf of the bidder. The entire cost of preparing and providing responses shall be borne by the bidder.
- e) The City reserves the right to request any additional information it deems necessary from any or all bidders after the submission deadline.
- f) The request for bid is not to be construed as an offer, a contract, or a commitment of any kind; nor does it commit the city to pay for any costs incurred by bidder in preparation. It shall be clearly understood that any costs incurred by the Proposer in responding to this request for proposal is at the bidder's own risk and expense as a cost of doing business. The City of Fayetteville shall not be liable for reimbursement to the Proposer for any expense so incurred, regardless of whether or not the proposal is accepted.
- g) If products, components, or services other than those described in this bid document are proposed, the bidder must include complete descriptive literature for each. All requests for additional information must be received within five working days following the request.
- h) **NOTE: Any uncertainties shall be brought to the attention to Andrea Foren immediately via telephone (479.575.8220) or e-mail ( [aforen@fayetteville-ar.gov](mailto:aforen@fayetteville-ar.gov) ). It is the intent and goal of the City of Fayetteville Purchasing Division to provide documents providing a clear and accurate understanding of the scope of work to be completed and/or goods to be provided. We encourage all interested parties to ask questions to enable all bidders to be on equal bidding terms.**
- i) Any inquiries or requests for explanation in regard to the City's requirements should be made promptly to Andrea Foren, City of Fayetteville, Purchasing Agent via e-mail ([aforen@fayetteville-ar.gov](mailto:aforen@fayetteville-ar.gov)) or telephone (479.575.8220).

No oral interpretation or clarifications will be given as to the meaning of any part of this request for proposal. All questions, clarifications, and requests, together with answers, if any, will be provided to all firms via written addendum. Names of firms submitting any questions, clarifications, or requests will not be disclosed until after a contract is in place.

- j) Any information provided herein is intended to assist the bidder in the preparation of proposals necessary to properly respond to this bid. The bid is designed to provide qualified Proposers with sufficient basic information to submit proposals meeting minimum specifications and/or test requirements, but is not intended to limit a bid's content or to exclude any relevant or essential data.
- k) Bidders irrevocably consent that any legal action or proceeding against it under, arising out of or in any manner relating to this Contract shall be prevailed by Arkansas law. Proposer hereby expressly and irrevocably waives any claim or defense in any said action or proceeding based on any alleged lack of jurisdiction or improper venue or any similar basis.
- l) The successful bidder shall not assign the whole or any part of this Contract or any monies due or to become due hereunder without written consent of City of Fayetteville. In case the successful bidder assigns all or any part of any monies due or to become due under this Contract, the Instrument of assignment shall contain a clause substantially to the effect that is agreed that the right of the assignee in and to any monies due or to become due to the successful bidder shall be subject to prior liens of all persons, firms, and corporations for services rendered or materials supplied for the performance of the services called for in this contract.
- m) The successful bidder's attention is directed to the fact that all applicable Federal and State laws, municipal ordinances, and the rules and regulations of all authorities having jurisdiction over the services shall apply to the contract throughout, and they will be deemed to be included in the contract as though written out in full herein. The successful bidder shall keep himself/herself fully informed of all laws, ordinances and regulations of the Federal, State, and municipal governments or authorities in any manner affecting those engaged or employed in providing these services or in any way affecting the conduct of the services and of all orders and decrees of bodies or tribunals having any jurisdiction or authority over same. If any discrepancy or inconsistency should be discovered in these Contract Documents or in the specifications herein referred to, in relation to any such law, ordinance, regulation, order or decree, s/he shall herewith report the same in writing to City of Fayetteville.

**26. ATTACHMENTS TO BID DOCUMENTS:** Enclosed technical specifications



**City of Fayetteville**  
**Bid 14-23, Trail Lighting – Equipment Only**  
**Technical Specifications: Luminaires and Poles**

---

**1. GENERAL:**

- 1.1 All unit(s) bid shall meet or exceed the minimum requirements or they shall be deemed incomplete and will not be considered for bid award.
- 1.2 All specifications written are to minimums, unless otherwise noted.
- 1.3 Vendor shall include this section with bid. In the event the bid line specification item meets the specification provided, bidder shall indicate with a check mark, writing in "yes" or other mark clearly indicating the item bid meets the individual specification. In the event the item bid does NOT meet the specification, bidder shall write in **"no" or leave the item blank**, indicating the item bid does not meet the specification. Bidders shall not be allowed to indicate if a specification is intended to be met after the deadline has passed. The City of Fayetteville shall not accept other literature for bid specification interpretation.
- 1.4 Unit(s) bid shall be new and of the latest standard production model as offered for commercial trade.
- 1.5 Pricing bid shall be inclusive of all items, shipping, and warranty. Bid pricing shall NOT include sales tax. Sales tax will apply to this project but will not be considered for bid evaluation.
- 1.6 City intends on placing an initial order for 52 each of luminaires and poles. The City intends to purchase off this bid on an as-needed basis through 12/31/2014 given the awarded vendor will hold pricing firm. City will not purchase off this bid with any associated price increase.
- 1.7 Award evaluation: Bids shall be evaluated and awarded by line item to the most responsive responsible bidder. Bidders are not required to bid on all line items. The City reserves the right to award this bid to multiple vendors in an effort to obtain the most cost effective purchase.

**2. ITEM 1 – LUMINAIRE / FIXTURE:**

- a.  Luminaire: Initial estimated quantity of 52) – Model #PT40 / DPM-3M / LED-H3-5.0K-6.5L-100W / BLK - Flat Polycarbonate lens or LEXAN, Type III, Full Cutoff by Amerlux Exterior or approved equal as determined by the City.
- b.  Purchase additional quantities on an as-needed bases through 12/31/14 with no price increase.
- c.  Power Factor of > .90
- d.  100 W maximum
- e.  80 foot pole spacing with minimum 0.5 foot candle
- f.  LM 79 Photometric report shall be provided with bid
- g.  Less than 5% loss to BUG – Backlight, Uplight and Glare
- h.  Type 3 light distribution

- i. \_\_\_ 80 lumens per watt efficiency minimum
- j. \_\_\_ Thermal losses should be less than 10% when operated at a steady state at an average ambient operating temperature of 25°C (77°F), and optical losses should be less than 15%. A thermal management system shall be included.
- k. \_\_\_ Nominal CCT - 4100K
- l. \_\_\_ CRI >70
- m. \_\_\_ 5-Year Warranty on Manufacturers Defects. Warranty shall include transportation to and from the City at no additional expense to the City.
- n. \_\_\_ Average delivered lumens over 50,000 hours shall be minimum of 85% of initial delivered lumens. Lumen maintenance shall be approved through one of two LM80 validation methods.
- o. \_\_\_ Ingress Protection (Dust and Water Intrusion) – IP > 65. Luminaire shall include a water tight gasket or breathable gasket at seam between the lens and luminaire body.
- p. \_\_\_ Driver shall include built in surge protection
- q. \_\_\_ Color: Satin Black
- r. \_\_\_ Fixture shall meet the following measurements, shape, and form:

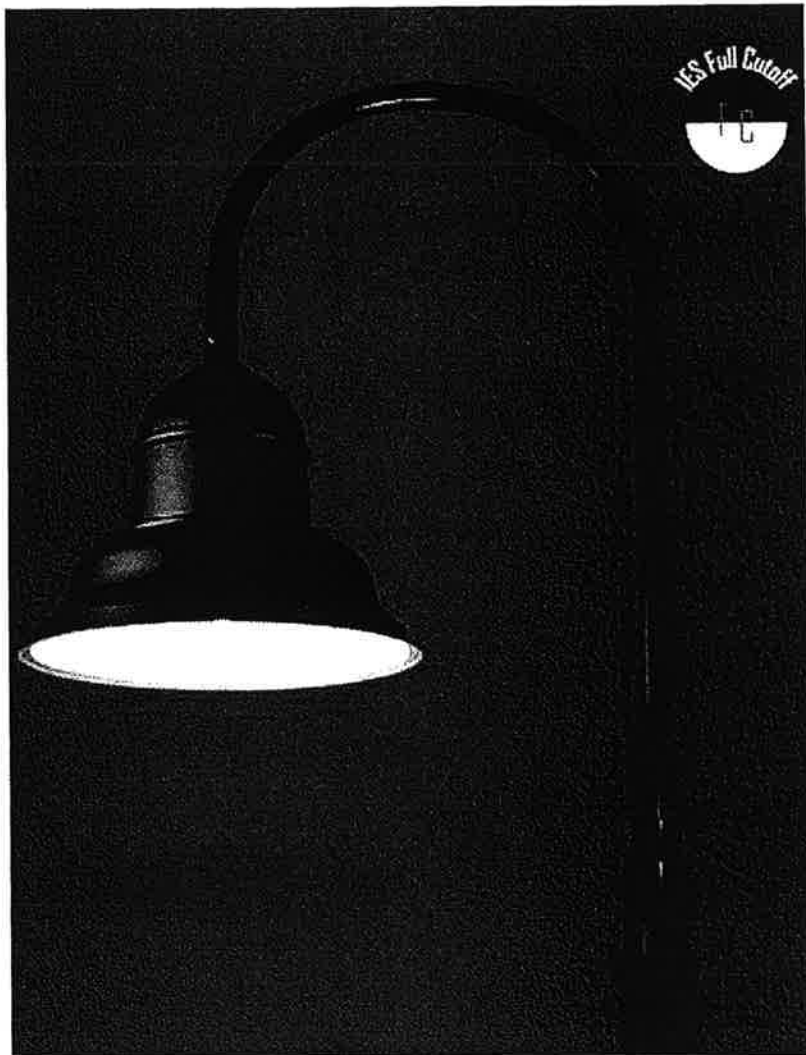

3. ITEM 2: POLE:

- a.      **Pole (Quantity 52)** – Direct Bury 12' Composite Materials Technology (CMT) Legacy fiberglass pole black with decorative base as shown below
- b.      Model #LFY12-T-3-T400X4.5-S with 4" O.D. tenon or Alliance Composites DS15ASDS4-JXB, or other approved equal.
- c.      Lifetime warranty on fiber-blooming
- d.      Three (3) year warranty on defects. Warranty shall include transportation to and from the City at no additional expense to the City.
- e.      Pole shall meet the following measurements, shape, and form:
- f.      Purchase additional quantities on an as-needed bases through 12/31/14 with no price increase.

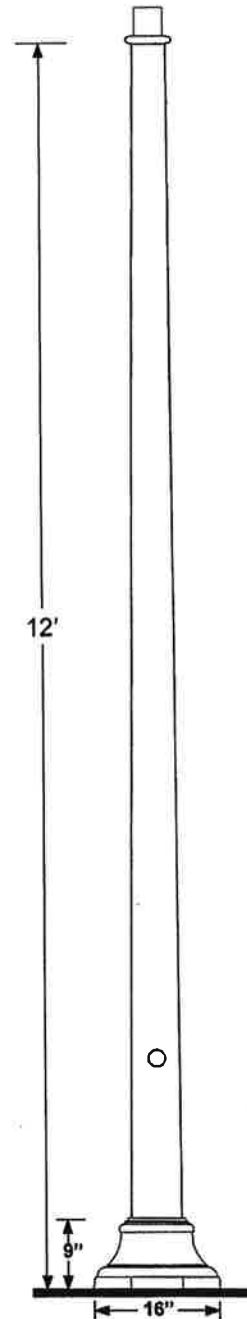

**5. STANDARDS:**

5.1 Each unit shall meet or exceed the following applicable standards.

- a. \_\_\_ Any applicable Occupational Safety and Health Administration Standards (OSHA).
- b. \_\_\_ Any applicable Arkansas State Highway Commission Regulations regarding vehicle markings, lighting and reflectors

**6. DELIVERY / DOCUMENTATION:**

6.1 All units are to be delivered F.O.B. to the City's Transportation Division, located at 1455 S. Happy Hollow Road, Fayetteville, Arkansas 72701, for compliance review and final acceptance.

6.2 Delivery shall include the following documents as a minimum:

- a. \_\_\_ Dealer invoice
- b. \_\_\_ Units shall be fully assembled, serviced, and ready for operation as delivered; however, fixtures shall not be mounted to poles.

6.3 Payment(s) may be held until all units are delivered.



City of Fayetteville, Arkansas  
Purchasing Division – Room 306  
113 W. Mountain  
Fayetteville, AR 72701  
Phone: 479.575.8220  
TDD (Telecommunication Device for the Deaf): 479.521.1316

**INVITATION TO BID**

**INVITATION TO BID: Bid 14-23, Trail Lighting – Equipment Only**  
**DEADLINE: Thursday, April 03, 2014 before 2:00 PM, Local Time**  
**DELIVERY LOCATION: Room 306 – 113 W. Mountain, Fayetteville, AR 72701**  
**PURCHASING AGENT: Andrea Foren, CPPO, CPPB, [aforen@fayetteville-ar.gov](mailto:aforen@fayetteville-ar.gov)**  
**DATE OF ISSUE AND ADVERTISEMENT: Friday, March 14, 2014**

**INVITATION TO BID**  
**Bid 14-23, Trail Lighting – Equipment Only**

No late bids will be accepted. Bids shall be submitted in sealed envelopes labeled with the name and address of the bidder.

All bids shall be submitted in accordance with the attached City of Fayetteville specifications and bid documents attached hereto. Each bidder is required to fill in every blank and shall supply all information requested; failure to do so may be used as basis of rejection.

The undersigned hereby offers to furnish & deliver the articles or services as specified, at the prices & terms stated herein, and in strict accordance with the specifications and general conditions of bidding, all of which are made a part of this offer. This offer is not subject to withdrawal unless upon mutual written agreement by the Proposer/Bidder and City Purchasing Manager.

Name of Firm: Whatley Inc  
Contact Person: Deb Lewis Title: Spec Sales Specialist  
E-Mail: alewis@whatley.com Phone: 877-959-7678 (239)  
Business Address: 3550 Odessa Way Ste A  
City: Aurora State: CO Zip: 80011  
Signature: Deb Lewis Date: 4/2/14

**City of Fayetteville**  
**Bid 14-23, Trall Lighting – Equipment Only**  
**Bid Form**

**DATE REQUIRED AS A COMPLETE UNIT: Delivery shall be made within 12 weeks from date of received Purchase Order.**

F.O.B. Transportation Division, 1455 S. Happy Hollow Rd., Fayetteville, AR 72701

Item	Description	Initial Estimated Quantity	Price Per Each	Total Line Item Price
1	Luminare, Model #PT40 / DPM-3M / LED-HS 5.0K-6.5K-100W / BLK Flat Polycarbonate lens or LEXAN, Type II, Full Cutoff made by Armetlux Exterior or approved equal as determined by the City of Fayetteville.	52		
Please Specify for Unit(s) Bid for Item #1: *MANUFACTURER: <i>No Bid</i> *MODEL: _____				
2	Pole: Direct Bury 12' Composite Materials Technology (CMT) Legacy fiberglass pole black with decorative base, Model #LFY12-T-3-T400X4-5-5 with 4" O.D. tenon or Alliance Composites DS15ASDS4-JX6, or other approved equal as determined by the City of Fayetteville.	52	\$ <i>572-</i>	\$ <i>29744</i>
Please Specify for Unit(s) Bid for Item #2: *MANUFACTURER: <i>Whatley Inc</i> *MODEL: <i>ST45-D10M-OCT-12-DE-STD-40-XX</i>				
<b>*TOTAL BASE BID:</b>				\$ <i>29744-</i>
*Total Base Bid shall be the calculated sum of items 1 and 2. Each line item shall be calculated by multiplying the Quantity times Price per Each. Price Per Each shall be inclusive of the item, freight, shipping, etc.				

Bids must be submitted on this bid form in its entirety AND accompanied by descriptive literature on the products being bid.

**THIS BID FORM CONTINUES ON THE NEXT PAGE.**

**AGENCY:** Illuminetics  
**PROJECT:** City of Fayetteville  
**QUOTE#:** 251570-01

**POLE**  
 Model: ST45  
 Top Dia: 4.5"  
 Taper: .14"/ft  
 Construction: Fiberglass Composite 72% Glass  
 28% Epoxy Resin consisting of alternating  
 89° Hoops and 18° Helicals,  
 non-conductive chemically inert.  
 Hand hole area reinforced. min 1/8" wall.  
 Hand Hole: 2 1/2"x5"@14" above grade with  
 cover painted to match pole  
 Wire Entry: 2 1/2"x5" @ 24" below grade  
 Tenon: 4" OD xx" Exposed(Customer to specify)  
 6061-T6 Aluminum  
 Post Top Ring: Heavy Cast Alum.  
 Paint: UV & Cleaning Chemical Resistant  
 Color: Whatley Standard-(Customer to specify)  
 Pole Weight: Approx 49 lbs  
 MAX Attachment Weight:150 lbs  
 MAX Attachment EPA: 10 @ 90 mph

**BASE COVER**  
 Model: D10MOCT  
 Material: Elastomeric Urethane  
 Color: Whatley Standard (Customer to specify)  
 Height: 9.25"  
 Width: 15.75"  
 Weight: Approx 9 lbs

**HAND HOLE COVER DETAIL**

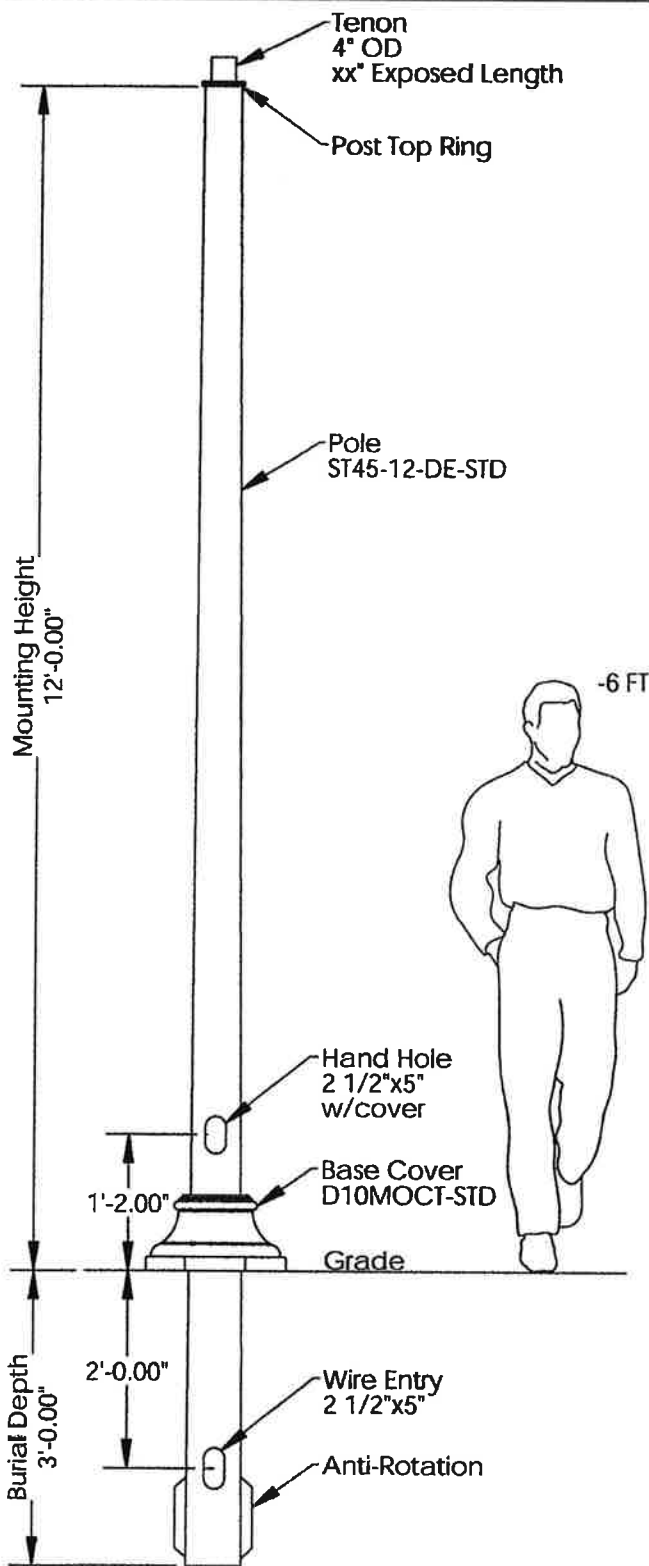
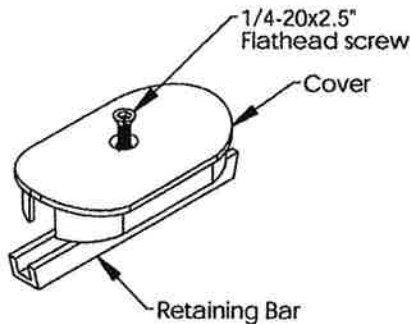

**WHATLEY, INC.** A Valmont Company  
 3550 Odessa Way, STE A  
 Aurora, CO., 80011  
 phone: (877) 959-7678  
 fax: (303) 286-7272  
 web: www.whatley.com

REV	DESCRIPTION	DATE

PART NO. ST45-D10MOCT-12-DE-STD-40-xx DESCRIPTION: Pole Assembly

SCALE: 1:22 SIZE: A REV.

MATERIAL: Noted  
 FINISH: Smooth

DOCUMENTATION	INITIAL	DATE
DRAWN	JTC	4/2/14
QUOTE REQUEST		
TOOLING REQUEST		
FIRST ARTICLE REQUEST		
FIRST ARTICLE INSPECTION		
PRODUCTION RELEASE		

UNLESS OTHERWISE NOTED:  
 DIMENSIONS ARE IN INCHES  
 TOLERANCES:  
 DECIMAL .XX ± .03  
 DECIMAL .XXX ± .010  
 ANGLE ± 1/2

**PROPRIETARY AND CONFIDENTIAL**  
 THE INFORMATION CONTAINED IN THIS  
 DRAWING IS THE SOLE PROPERTY OF  
 WHATLEY, INC. ANY REPRODUCTION IN  
 PART OR AS A WHOLE WITHOUT THE  
 WRITTEN PERMISSION OF WHATLEY, INC. IS  
 PROHIBITED.

**DO NOT SCALE DRAWING**





\*PHONE: 877-959-7678 FAX: 303-286-7216

\*E-MAIL: clewis@whatley.com

\*BY: (PRINTED NAME) \_\_\_\_\_

\*AUTHORIZED SIGNATURE: Delo Lewis

\*TITLE: Spec Sales Specialist

\*DUNS NUMBER: \_\_\_\_\_ CAGE NUMBER: \_\_\_\_\_

\*TAX ID NUMBER: CO-00173649-0000

Acknowledge Addendums:

Addendum No. \_\_\_\_\_ Dated: \_\_\_\_\_ Acknowledged by: \_\_\_\_\_

Addendum No. \_\_\_\_\_ Dated: \_\_\_\_\_ Acknowledged by: \_\_\_\_\_

Addendum No. \_\_\_\_\_ Dated: \_\_\_\_\_ Acknowledged by: \_\_\_\_\_

**City of Fayetteville**  
**Bid 14-23, Trail Lighting – Equipment Only**  
**General Terms and Conditions**

**1. SUBMISSION OF BID & BID EVALUATION:**

- a. Bids shall be reviewed following the stated deadline, as shown on the cover sheet of this document.
- b. Bidders shall submit bids based on documentation published by the Fayetteville Purchasing Division.
- c. Bids shall be enclosed in sealed envelopes or packages addressed to the City of Fayetteville, Purchasing Division, Room 306, 113 W. Mountain, Fayetteville, AR 72701. The name, address of the firm and Bid, RFP, or RFQ number shall be on the outside of the packaging as well as on any packages enclosed in shipping containers or boxes.
- d. The City will not be responsible for misdirected bids. Vendor should call the Purchasing Office at 479.575.8220 to ensure correct receipt of bidding documents prior to opening time and date listed on the bid form.
- e. Bidders must have experience in providing products and/or services of the same or similar nature.
- f. Bidder is advised that exceptions to any of the terms contained in this bid must be identified in its response to the bid. Failure to do so may lead the City to declare any such term non-negotiable. Proposer's desire to take exception to a non-negotiable term will not disqualify it from consideration for award.
- g. Local time is defined as the time in Fayetteville, Arkansas on the due date of the deadline. Bids shall be received before the time as shown by the atomic clock located in the Purchasing Division Office.
- h. Bids will be evaluated and awarded based on the best interest of the City of Fayetteville. The City reserves the right to award bids in their entirety, none, or by line item.

**2. WRITTEN REQUESTS FOR INTERPRETATIONS OR CLARIFICATION:**

No oral interpretations will be made to any firms as to the meaning of specifications or any other contract documents. All questions pertaining to the terms and conditions or scope of work of this bid must be sent in writing via e-mail to the Purchasing Agent. Responses to questions may be handled as an addendum if the response would provide clarification to the requirements of the bid. All such addenda shall become part of the contract documents. The City will not be responsible for any other explanation or interpretation of the proposed bid made or given prior to the award of the contract.

**3. DESCRIPTION OF SUPPLIES AND SERVICES:**

Any reference to a particular brand or manufacturer is done in an effort to establish an acceptable level of quality for this project. Brands or manufacturers that are included in bid that are of at least equal quality, size, design, and specification as to what has been specified, will be acceptable for consideration only if approved by the City of Fayetteville Purchasing Division. The City of Fayetteville reserves the right to accept or reject any requested equal.

**4. RIGHTS OF CITY OF FAYETTEVILLE BID PROCESS:**

In addition to all other rights of the City of Fayetteville, under state law, the City specifically reserves the following:

- a. The City of Fayetteville reserves the right to select the bid that it believes will serve the best interest of the City.
- b. The City of Fayetteville reserves the right to accept or reject any or all bids.
- c. The City of Fayetteville reserves the right to cancel the entire bid.
- d. The City of Fayetteville reserves the right to remedy or waive technical or immaterial errors in the invitation to bid or in bids submitted.

- e. The City of Fayetteville reserves the right to request any necessary clarifications, additional information, or data without changing the terms of the bid.

**5. COSTS INCURRED BY BIDDERS:**

All expenses involved with the preparation and submission of bids to the City, or any work performed in connection therewith, shall be borne solely by the bidder(s). No payment will be made for any responses received, or for any other effort required of, or made by, the bidder(s) prior to contract commencement.

**6. CONFLICT OF INTEREST:**

- a. The bidder represents that it presently has no interest and shall acquire no interest, either direct or indirect, which would conflict in any manner with the performance or services required hereunder, as provided in City of Fayetteville Code Section 34.26 titled "Authority of City Employee to Contract With The City".
- b. All bidders shall promptly notify Andrea Foren, City Purchasing Agent, in writing, of all potential conflicts of interest for any prospective business association, interest, or other circumstance which may influence or appear to influence the bidder's judgment or quality of services being provided. Such written notification shall identify the prospective business association, interest or circumstance, the nature of which the bidder may undertake and request an opinion to the City as to whether the association, interest or circumstance would, in the opinion of the City, constitute a conflict of interest if entered into by the bidder. The City agrees to communicate with the bidder its opinion via e-mail or first-class mail within thirty days of receipt of notification.

**7. WITHDRAWAL OF PROPOSAL:**

A bid may be withdrawn prior to the time set for the bid submittal, based on a written request from an authorized representative of the firm; however, a bid shall not be withdrawn after the time set for the bid unless approved by the Purchasing Division.

**8. LATE PROPOSAL OR MODIFICATIONS:**

- 1. Bid modifications received after the time set for the bid submittal shall not be considered. Modifications in writing received prior to the deadline will be accepted. The City will not be responsible for misdirected bids. Bidders should call the Purchasing Division at (479) 575-8220 to insure receipt of their submittal documents prior to opening time and date listed.

**9. LOCAL, STATE, AND FEDERAL COMPLIANCE REQUIREMENTS:**

- a. The laws of the State of Arkansas apply to any purchase made under this bid. Bidders shall comply with all local, state, and federal directives, orders and laws as applicable to this proposal and subsequent contract(s) including but not limited to Equal Employment Opportunity (EEO), Disadvantaged Business Enterprises (DBE), & OSHA as applicable to this contract.
- b. Pursuant to Arkansas Code Annotated §22-9-203 The City of Fayetteville encourages all *qualified* small, minority and women business enterprises to bid on and receive contracts for goods, services, and construction. Also, City of Fayetteville encourages all general contractors to subcontract portions of their contract to *qualified* small, minority and women business enterprises.

**10. PROVISION FOR OTHER AGENCIES:**

Unless otherwise stipulated by the bidder, the bidder agrees to make available to all Government agencies, departments, municipalities, and counties, the proposal prices submitted in accordance with said proposal terms and conditions therein, should any said governmental entity desire to buy under this proposal. Eligible Users shall mean all state of Arkansas agencies, the legislative and judicial branches, political subdivisions (counties, local district school boards, community colleges, municipalities, counties, or other public agencies or authorities), which may desire to purchase under the terms and conditions of the contract.

**11. COLLUSION:**

The Proposer, by affixing his or her signature to this proposal, agrees to the following: "bidder certifies that his or her bid is made without previous understanding, agreement, or connection with any person, firm or corporation making a proposal for the same item(s) and/or services and is in all respects fair, without outside control, collusion, fraud, or otherwise illegal action."

**12. RIGHT TO AUDIT, FOIA, AND JURISDICTON:**

- a. The City of Fayetteville reserves the privilege of auditing a vendor's records as such records relate to purchases between the City and said vendor.
- b. Freedom of Information Act: City contracts and documents prepared while performing City contractual work are subject to the Arkansas Freedom of Information Act. If a Freedom of Information Act request is presented to the City of Fayetteville, the (Contractor) will do everything possible to provide the documents in a prompt and timely manner as prescribed in the Arkansas Freedom of Information Act (A.C.A. §25-19-101 et. seq.). Only legally authorized photocopying costs pursuant to the FOIA may be assessed for this compliance.
- c. Legal jurisdiction to resolve any disputes shall be in Washington County, Arkansas with Arkansas law applying to the case.

**13. CITY INDEMNIFICATION:**

The successful bidder(s) agrees to indemnify the City and hold it harmless from and against all claims, liability, loss, damage or expense, including but not limited to counsel fees, arising from or by reason of any actual or claimed trademark, patent or copyright infringement or litigation based thereon, with respect to the goods or any part thereof covered by this order, and such obligation shall survive acceptance of the goods and payment thereof by the City.

**14. VARIANCE FROM STANDARD TERMS & CONDITIONS:**

All standard terms and conditions stated in this request for bid apply to this contract except as specifically stated in the subsequent sections of this document, which take precedence, and should be fully understood by bidders prior to submitting a proposal on this requirement.

**15. ADA REQUIREMENT FOR PUBLIC NOTICES & TRANSLATION:**

Persons with disabilities requiring reasonable accommodation to participate in this proceeding/event, should call 479.521.1316 (telecommunications device for the deaf), not later than seven days prior to the deadline. Persons needing translation of this document shall contact the City of Fayetteville, Purchasing Division, immediately.

**16. PROCUREMENT POLICY FOR RECYCLED MATERIALS:**

The City of Fayetteville wishes to encourage its bidders to use recycled products in fulfilling contractual obligations to the City and that such practices will serve as a model for other public entities and private sector companies.

**17. PAYMENTS AND INVOICING:**

The bidder must specify in their bid the exact company name and address which must be the same as invoices submitted for payment as a result of award of this bid. Further, the successful bidder is responsible for immediately notifying the Purchasing Division of any company name change, which would cause invoicing to change from the name used at the time of the original bid. Payment will be made within thirty days of invoice received. The City of Fayetteville is very credit worthy and will not pay any interest, fees, or penalty for untimely payments. Payments can be processed through bidder's acceptance of Visa at no additional costs to the City for expedited payment processing. The City will not agree to any nonrefundable deposit or retainer that would remain property of the bidder even if the hourly work actually performed by the bidder would not justify such fee.

The City will pay the awarded bidder based on unit prices provided on invoicing. Progress payments will be made after

approval and acceptance of work and submission of invoice. Payments will be made within 30 days of accepted invoice.

**18. CANCELLATION:**

- a. The City reserves the right to cancel this contract without cause by giving thirty (30) days prior notice to the Contractor in writing of the intention to cancel or with cause if at any time the Contractor fails to fulfill or abide by any of the terms or conditions specified.
- b. Failure of the contractor to comply with any of the provisions of the contract shall be considered a material breach of contract and shall be cause for immediate termination of the contract at the discretion of the City of Fayetteville.
- c. In addition to all other legal remedies available to the City of Fayetteville, the City reserves the right to cancel and obtain from another source, any items and/or services which have not been delivered within the period of time from the date of order as determined by the City of Fayetteville.
- d. In the event sufficient budgeted funds are not available for a new fiscal period, the City shall notify the vendor of such occurrence and contract shall terminate of the last day of the current fiscal period without penalty or expense to the City

**19. ASSIGNMENT, SUBCONTRACTING, CORPORATE ACQUISITIONS AND/OR MERGERS:**

- a. The Contractor shall perform this contract. No assignment of subcontracting shall be allowed without prior written consent of the City. If a bidder intends to subcontract a portion of this work, the bidder shall disclose such intent in the bid submitted as a result of this bid.
- b. In the event of a corporate acquisition and/or merger, the Contractor shall provide written notice to the City within thirty (30) calendar days of Contractor's notice of such action or upon the occurrence of said action, whichever occurs first. The right to terminate this contract, which shall not be unreasonably exercised by the City, shall include, but not be limited to, instances in which a corporate acquisition and/or merger represent a conflict of interest or are contrary to any local, state, or federal laws. Action by the City awarding a proposal to a firm that has disclosed its intent to assign or subcontract in its response to the bid, without exception shall constitute approval for purpose of this Agreement.

**20. NON-EXCLUSIVE CONTRACT:**

Award of this bid shall impose no obligation on the City to utilize the vendor for all work of this type, which may develop during the contract period. This is not an exclusive contract. The City specifically reserves the right to concurrently contract with other companies for similar work if it deems such an action to be in the City's best interest. In the case of multiple-term contracts, this provision shall apply separately to each item.

**21. LOBBYING:**

Lobbying of selection committee members, City of Fayetteville employees, or elected officials regarding request for proposals, request for qualifications, bids or contracts, during the pendency of bid protest, by the bidder/proposer/protestor or any member of the bidder's/proposer's/protestor's staff, and agent of the bidder/proposer/protestor, or any person employed by any legal entity affiliated with or representing an organization that is responding to the request for proposal, request for qualification, bid or contract, or has a pending bid protest is strictly prohibited either upon advertisement or on a date established by the City of Fayetteville and shall be prohibited until either an award is final or the protest is finally resolved by the City of Fayetteville; provided, however, nothing herein shall prohibit a prospective/bidder/proposer from contacting the Purchasing Division to address situations such as clarification and/or questions related to the procurement process. For purposes of this provision lobbying activities shall include but not be limited to, influencing or attempting to influence action or non-action in connection with any request for proposal, request for qualification, bid or contract through direct or indirect oral or written communication or an attempt to obtain goodwill of persons and/or entities specified in this provision. Such actions may cause any request for proposal, request for qualification, bid or contract to be rejected.

**22. ADDITIONAL REQUIREMENTS:**

City of Fayetteville, AR  
Bid 14-23, Trail Lighting – Equipment Only  
Page 8 of 14

The City reserves the right to request additional services relating to this bid from the bidder. When approved by the City as an amendment to the contract and authorized in writing prior to work, the Contractor shall provide such additional requirements as may become necessary.

**23. ADD OR DELETE LOCATIONS OR SERVICES:**

The City reserves the right to unilaterally add or delete locations and/or services, either collectively or individually, at the City's sole option, at any time after award has been made as may be deemed necessary or in the best interests of the City. In such case, the Contractor(s) will be required to provide services to this contract in accordance with the terms, conditions, and specifications.

**24. INTEGRITY OF BID DOCUMENTS:**

Bidders shall use the original bid form(s) provided by the Purchasing Division and enter information only in the spaces where a response is requested. Bidders may use an attachment as an addendum to the bid form(s) if sufficient space is not available on the original form for the bidder to enter a complete response. Any modifications or alterations to the original documents by the bidder, whether intentional or otherwise, will constitute grounds for rejection of such response. Any such modifications or alterations a bidder wishes to propose shall be clearly stated in the bidder's response and presented in the form of an addendum to the original bid documents.

**25. OTHER GENERAL CONDITIONS:**

- a) Bidder is presumed to be familiar with all federal, state, and city laws, ordinances, and regulations which in any manner affect those engaged or employed in the Work, or the materials or equipment used, or that in any way affect the Work and shall in all respects comply with said laws, ordinances, and regulations. No claim of misunderstanding or ignorance on the part of Bidder or Proposer will in any way serve to modify the provisions of the contract. No representations shall be binding unless embodied in the contract.
- b) Prices shall include all labor, materials, overhead, profit, insurance, shipping, freight, etc., to cover the products and services presented. *Sales tax is not to be included in the bid price.* Applicable Arkansas sales tax laws will apply when necessary but will not be considered in award of this project.
- c) Each bidder should state the anticipated number of days from the date of receipt of an order for delivery of services to the City of Fayetteville.
- d) Bidders must provide the City with their bids signed by an employee having legal authority to submit bids on behalf of the bidder. The entire cost of preparing and providing responses shall be borne by the bidder.
- e) The City reserves the right to request any additional information it deems necessary from any or all bidders after the submission deadline.
- f) The request for bid is not to be construed as an offer, a contract, or a commitment of any kind; nor does it commit the city to pay for any costs incurred by bidder in preparation. It shall be clearly understood that any costs incurred by the Proposer in responding to this request for proposal is at the bidder's own risk and expense as a cost of doing business. The City of Fayetteville shall not be liable for reimbursement to the Proposer for any expense so incurred, regardless of whether or not the proposal is accepted.
- g) If products, components, or services other than those described in this bid document are proposed, the bidder must include complete descriptive literature for each. All requests for additional information must be received within five working days following the request.
- h) **NOTE:** Any uncertainties shall be brought to the attention to Andrea Foren immediately via telephone (479.575.8220) or e-mail ( [aforen@fayetteville-ar.gov](mailto:aforen@fayetteville-ar.gov) ). It is the intent and goal of the City of Fayetteville Purchasing Division to provide documents providing a clear and accurate understanding of the scope of work to be completed and/or goods to be provided. We encourage all interested parties to ask questions to enable all bidders to be on equal bidding terms.
- i) Any inquiries or requests for explanation in regard to the City's requirements should be made promptly to Andrea Foren, City of Fayetteville, Purchasing Agent via e-mail ([aforen@fayetteville-ar.gov](mailto:aforen@fayetteville-ar.gov)) or telephone (479.575.8220).

No oral interpretation or clarifications will be given as to the meaning of any part of this request for proposal. All questions, clarifications, and requests, together with answers, if any, will be provided to all firms via written addendum. Names of firms submitting any questions, clarifications, or requests will not be disclosed until after a contract is in place.

- j) Any information provided herein is intended to assist the bidder in the preparation of proposals necessary to properly respond to this bid. The bid is designed to provide qualified Proposers with sufficient basic information to submit proposals meeting minimum specifications and/or test requirements, but is not intended to limit a bid's content or to exclude any relevant or essential data.
- k) Bidders irrevocably consent that any legal action or proceeding against it under, arising out of or in any manner relating to this Contract shall be prevailed by Arkansas law. Proposer hereby expressly and irrevocably waives any claim or defense in any said action or proceeding based on any alleged lack of jurisdiction or improper venue or any similar basis.
- l) The successful bidder shall not assign the whole or any part of this Contract or any monies due or to become due hereunder without written consent of City of Fayetteville. In case the successful bidder assigns all or any part of any monies due or to become due under this Contract, the instrument of assignment shall contain a clause substantially to the effect that is agreed that the right of the assignee in and to any monies due or to become due to the successful bidder shall be subject to prior liens of all persons, firms, and corporations for services rendered or materials supplied for the performance of the services called for in this contract.
- m) The successful bidder's attention is directed to the fact that all applicable Federal and State laws, municipal ordinances, and the rules and regulations of all authorities having jurisdiction over the services shall apply to the contract throughout, and they will be deemed to be included in the contract as though written out in full herein. The successful bidder shall keep himself/herself fully informed of all laws, ordinances and regulations of the Federal, State, and municipal governments or authorities in any manner affecting those engaged or employed in providing these services or in any way affecting the conduct of the services and of all orders and decrees of bodies or tribunals having any jurisdiction or authority over same. If any discrepancy or inconsistency should be discovered in these Contract Documents or in the specifications herein referred to, in relation to any such law, ordinance, regulation, order or decree, s/he shall herewith report the same in writing to City of Fayetteville.

**26. ATTACHMENTS TO BID DOCUMENTS:** Enclosed technical specifications

**City of Fayetteville**  
**Bid 14-23, Trail Lighting – Equipment Only**  
**Technical Specifications: Luminaires and Poles**

**1. GENERAL:**

- 1.1 All unit(s) bid shall meet or exceed the minimum requirements or they shall be deemed incomplete and will not be considered for bid award.
- 1.2 All specifications written are to minimums, unless otherwise noted.
- 1.3 Vendor shall include this section with bid. In the event the bid line specification item meets the specification provided, bidder shall indicate with a check mark, writing in "yes" or other mark clearly indicating the item bid meets the individual specification. In the event the item bid does NOT meet the specification, bidder shall write in "no" or leave the item blank, indicating the item bid does not meet the specification. Bidders shall not be allowed to indicate if a specification is intended to be met after the deadline has passed. The City of Fayetteville shall not accept other literature for bid specification interpretation.
- 1.4 Unit(s) bid shall be new and of the latest standard production model as offered for commercial trade.
- 1.5 Pricing bid shall be inclusive of all items, shipping, and warranty. Bid pricing shall NOT include sales tax. Sales tax will apply to this project but will not be considered for bid evaluation.
- 1.6 City intends on placing an initial order for 52 each of luminaires and poles. The City intends to purchase off this bid on an as-needed basis through 12/31/2014 given the awarded vendor will hold pricing firm. City will not purchase off this bid with any associated price increase.
- 1.7 Award evaluation: Bids shall be evaluated and awarded by line item to the most responsive responsible bidder. Bidders are not required to bid on all line items. The City reserves the right to award this bid to multiple vendors in an effort to obtain the most cost effective purchase.

**2. ITEM 1 – LUMINAIRE / FIXTURE:**

- a.  Luminaire: Initial estimated quantity of 52) – Model #PT40 / DPM-3M / LED-H3-5.0K-6.5L-100W / BLK - Flat Polycarbonate lens or LEXAN, Type III, Full Cutoff by Amerlux Exterior or approved equal as determined by the City.
- b.  Purchase additional quantities on an as-needed bases through 12/31/14 with no price increase.
- c.  Power Factor of > .90
- d.  100 W maximum
- e.  80 foot pole spacing with minimum 0.5 foot candle
- f.  LM 79 Photometric report shall be provided with bid
- g.  Less than 5% loss to BUG – Backlight, Uplight and Glare
- h.  Type 3 light distribution



- i.  80 lumens per watt efficiency minimum
- j.  Thermal losses should be less than 10% when operated at a steady state at an average ambient operating temperature of 25°C (77°F), and optical losses should be less than 15%. A thermal management system shall be included.
- k.  Nominal CCT - 4100K
- l.  CRI >70
- m.  5-Year Warranty on Manufacturers Defects. Warranty shall include transportation to and from the City at no additional expense to the City.
- n.  Average delivered lumens over 50,000 hours shall be minimum of 85% of initial delivered lumens. Lumen maintenance shall be approved through one of two LM80 validation methods.
- o.  Ingress Protection (Dust and Water Intrusion) – IP > 65. Luminaire shall include a water tight gasket or breathable gasket at seam between the lens and luminaire body.
- p.  Driver shall include built in surge protection
- q.  Color: Satin Black
- r.  Fixture shall meet the following measurements, shape, and form:

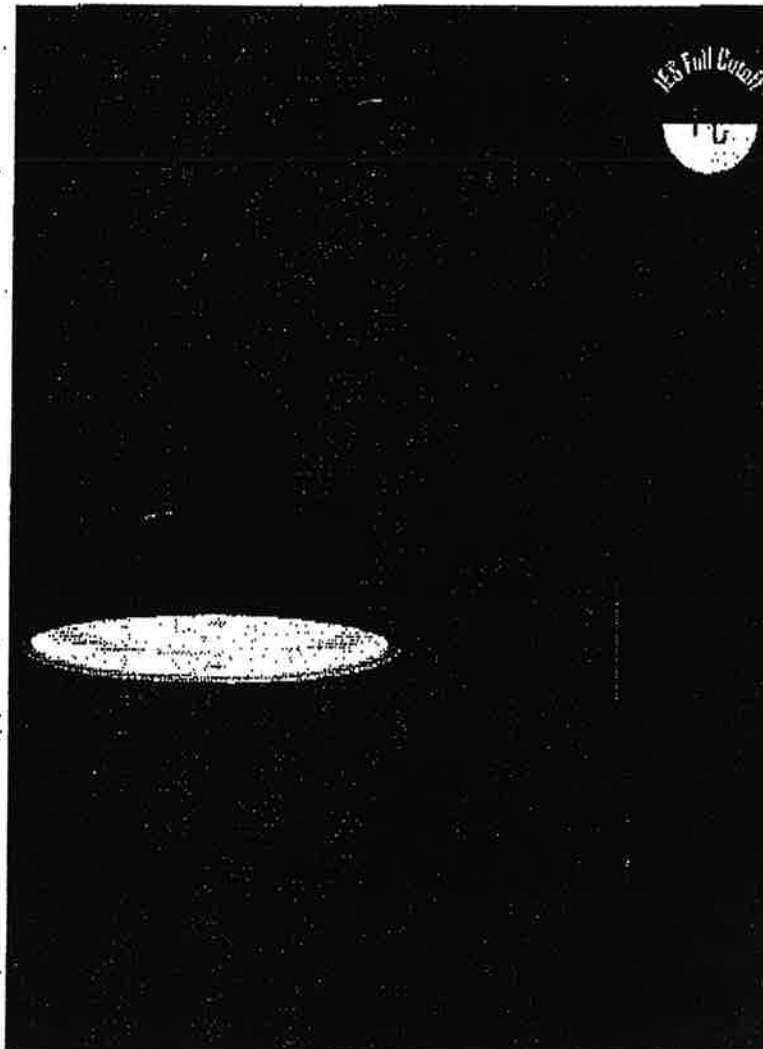

**3. ITEM 2: POLE:**

- a.      **Pole (Quantity 52) – Direct Bury 12' Composite Materials Technology (CMT) Legacy fiberglass pole black with decorative base as shown below**
- b.      **Model #LFY12-T-3-T400X4.5-S with 4" O.D. tenon or Alliance Composites DS15ASDS4-JXB, or other approved equal.**
- c.      **Lifetime warranty on fiber-blooming**
- d.      **Three (3) year warranty on defects. Warranty shall include transportation to and from the City at no additional expense to the City.**
- e.      **Pole shall meet the following measurements, shape, and form:**
- f.      **Purchase additional quantities on an as-needed bases through 12/31/14 with no price increase.**



**5. STANDARDS:**

- 5.1 Each unit shall meet or exceed the following applicable standards.
- a. \_\_\_ Any applicable Occupational Safety and Health Administration Standards (OSHA).
  - b. \_\_\_ Any applicable Arkansas State Highway Commission Regulations regarding vehicle markings, lighting and reflectors

**6. DELIVERY / DOCUMENTATION:**

- 6.1 All units are to be delivered F.O.B. to the City's Transportation Division, located at 1455 S. Happy Hollow Road, Fayetteville, Arkansas 72701, for compliance review and final acceptance.
- 6.2 Delivery shall include the following documents as a minimum:
- a. \_\_\_ Dealer invoice
  - b. \_\_\_ Units shall be fully assembled, serviced, and ready for operation as delivered; however, fixtures shall not be mounted to poles.
- 6.3 Payment(s) may be held until all units are delivered.

<b>City Of Fayetteville - Purchase Order (PO) Request</b> <small>(Not a Purchase Order)</small> <i>All purchases under \$2500 shall be used on a P-Card unless medical or 1099 service related. (Call x256 with questions)</i> <i>All PO Request shall be scanned to the Purchasing e-mail: Purchasing@ci.fayetteville.ar.us</i>									
Requestion No.:		Date:		4/17/2014		Expected Delivery Date:			
P.O Number:		Mail Yes: <input checked="" type="checkbox"/>		No: _____		Quotes Attached Yes: <input checked="" type="checkbox"/>		No: <input checked="" type="checkbox"/>	
Vendor #:		15814		Vendor Name:		W J Whatley, Inc. dba Whatley - A Valmont Co		Fob Point:	
Address:				Zip Code:		104		Ship to code:	
City:				State:				Requester's Employee #:	
Requester:		Ginny Gundlach		Account Numbers		2283		Inventory #	
Item Description		Quantity		Unit of Issue		Unit Cost		Extended Cost	
1 Tsa La GI Trail									
2 Light Poles		52		EA		572.00		\$29,744.00	
3								\$0.00	
4								\$0.00	
5								\$0.00	
6								\$0.00	
7								\$0.00	
8								\$0.00	
9								\$0.00	
10								\$0.00	
* Shipping/Handling				Lot				\$0.00	
Special Instructions: Per Bid 14-23 and Res xx-14									
Subtotal:								\$29,744.00	
Tax:								\$2,900.04	
Total:								\$32,644.04	
Approvals: Mayor: _____ Department Director: _____ Purchasing Manager: _____ Finance & Internal Services Director: _____ Budget Manager: _____ IT Manager: _____ Dispatch Manager: _____ Utilities Manager: _____ Other: _____									

Revised 12/2008

<b>City Of Fayetteville - Purchase Order (PO) Request</b> <small>(Not a Purchase Order)</small> All purchases under \$2500 shall be used on a P-Card unless medical or 1099 service related. (Call x256 with questions) All PO Request shall be scanned to the Purchasing e-mail: <a href="mailto:Purchasing@ci.fayetteville.ar.us">Purchasing@ci.fayetteville.ar.us</a>									
Requester No.:		Date:		4/17/2014		Expected Delivery Date:			
P.O Number:		Requester Name:		Robinson Electric Supply Co dba First Light Lighting		Fob Point:			
Vendor #:		24404		City:		State:			
Address:		Zip Code:		104		Ship to code:		104	
Requester:		Ginny Gundlach		Requester's Employee #:		2283		Account Numbers	
Item Description		Quantity		Unit of Issue		Unit Cost		Extended Cost	
1 Tsa La Gi Trail									
2 Luminaires		52		EA		1,674.00		\$87,048.00	
3								\$0.00	
4								\$0.00	
5								\$0.00	
6								\$0.00	
7								\$0.00	
8								\$0.00	
9								\$0.00	
10								\$0.00	
* Shipping/Handling				Lot				\$0.00	
Special Instructions: Per Bid 14-23 and Res xx-14									
Subtotal:								\$87,048.00	
Tax:								\$8,487.18	
Total:								\$95,535.18	
Approvals: Mayor: _____ Department Director: _____ Purchasing Manager: _____ Finance & Internal Services Director: _____ Budget Manager: _____ IT Manager: _____ Dispatch Manager: _____ Utilities Manager: _____ Other: _____									

Revised 1/2/2009

