

City of Fayetteville Staff Review Form

City Council Agenda Items
and
Contracts, Leases or Agreements

12/18/2012

City Council Meeting Date
Agenda Items Only

Yolanda Fields
Submitted By

Community Services
Division

Development Services
Department

Action Required:

Public Hearing and Resolution to order the Raze and Removal of the unsafe structure located at 320 W. North Street (WC Parcel # 765-10576-000) and approval of a Budget Adjustment in the amount of \$4,875.00

\$ 4,875.00
Cost of this request

\$ -
Category / Project Budget

Program Category / Project Name

1010.6420.5315.04
Account Number

\$ -
Funds Used to Date

Raze and Removal
Program / Project Category Name

Project Number

\$ -
Remaining Balance

General Fund
Fund Name

Budgeted Item

Budget Adjustment Attached

[Signature]
Department Director

11.27.2012
Date

Previous Ordinance or Resolution #

[Signature]
City Attorney

11-28-12
Date

Original Contract Date:

Original Contract Number:

Paul A. Baker
Finance and Internal Services Director

11-29-2012
Date

Received in City Clerk's Office
1-23-12 11:23 RCVD
USP

[Signature]
Chief of Staff

12-3-12
Date

Received in Mayor's Office
ENTERED
11/28/12
PH

[Signature]
Mayor

12/3/12
Date

Comments: Staff recommends the Raze and Removal of the structure and approval of the budget adjustment.

CITY COUNCIL AGENDA MEMO

To: Mayor and City Council

Thru: Jeremy Pate, Development Services Department Director 

From: Yolanda Fields, Community Services Director 

Date: November 26, 2012

Subject: Raze and Removal of structure at 320 W. North Street

RECOMMENDATION

Staff recommends approval of the Resolution ordering the Razing and Removal of a dilapidated and unsafe structure located at 320 W. North Street. Staff also recommends approval of the budget adjustment in the amount of \$4,875.00.

BACKGROUND

Service Request # 117200, Case # 15155: Code Compliance responded to a request concerning the structure located at 320 W. North Street. The structure appeared to be in violation of Subsection 173.09(A), Unsafe Buildings, of the City Code of Ordinances. The Chief Building Official inspected the property and determined that the structure was in violation of Subsection 173.09(A), Unsafe Buildings, of the City Code of Ordinances. Specifically, the Chief Building Official observed: *major deterioration of the house has occurred since last inspection. Roof soggy, soffit rotted out, and section of interior walls rotten with exposed interior section.* The roof, floors and ceiling have major damage and any repairs would require structure be brought up to current building codes.

On May 3, 2012, an Unsafe Building Notice of Violation was delivered to the property owner, Robert Wilkes. By ordinance, the property owner was given until June 4, 2012 to acquire a building permit or to raze and remove the structure. On October 26, 2012, a Notice of Public Hearing was delivered to the property owner informing him of the December 18, 2012 Public Hearing.

DISCUSSION

This parcel contains a 1,557 square foot, wood frame single family dwelling. The structure is secured, but has deteriorated to a point where it is no longer safe. There is not a current building permit on this structure.

BUDGET IMPACT

If the property owner does not comply with the Raze and Removal order, the cost for the Raze and Removal will be \$4,875. A Lien will be placed on the parcel for the incurred costs, pending City Council approval.

RESOLUTION NO. _____

A RESOLUTION ORDERING THE RAZING AND REMOVAL OF A DILAPIDATED AND UNSAFE STRUCTURE OWNED BY MISSION PROPERTIES, LLC LOCATED AT 320 W. NORTH STREET IN THE CITY OF FAYETTEVILLE, ARKANSAS, AND APPROVING A BUDGET ADJUSTMENT

WHEREAS, Robert W. Wilkes is the record owner of the real property situated at 320 W. North Street, City of Fayetteville, Washington County, Arkansas, more particularly described as follows:

WC Parcel Number 765-10576-000; and,

WHEREAS, the City Council has determined that the structure located on said property is dilapidated, unsightly, unsafe, and detrimental to the public welfare; and,

WHEREAS, Robert W. Wilkes, having been properly served with a Violation Notice via Certified Mail, Return Receipt Requested, and given thirty (30) days to correct said violation, has refused to repair, or raze and remove said dilapidated, unsightly, and unsafe structure.

NOW, THEREFORE, BE IT RESOLVED BY THE CITY COUNCIL OF THE CITY OF FAYETTEVILLE, ARKANSAS:

Section 1: That, by the authority granted pursuant to A.C.A. §14-56-203, and in accordance with the provisions of Ordinance No. 3948 of 1996, Robert W. Wilkes is hereby ordered to raze and remove forthwith, the dilapidated, unsightly, and unsafe structure located on the aforementioned real property. The manner of removing said structure shall be: dismantle by hand or bulldozer, and haul all debris to a landfill.

Section 2: That, if Robert W. Wilkes does not comply with this order, the Mayor is hereby directed to cause the dilapidated, unsightly, and unsafe structure to be razed and removed; and a lien against the real property shall be granted and given the City, pursuant to A.C.A. §14-54-904, for the costs associated therewith.

Section 3: That the City Council of the City of Fayetteville, Arkansas hereby approves a budget adjustment, a copy of which is attached to this Resolution as Exhibit "A".

PASSED and **APPROVED** this 18th day of December, 2012.

APPROVED:

ATTEST:

By: _____
LIONELD JORDAN, Mayor

By: _____
SONDRA E. SMITH, City Clerk/Treasurer







**City of Fayetteville, Arkansas
Budget Adjustment Form**

C. 1 V12.0724
Raze and Removal 320 W. North Street
Page 4 of 10

Budget Year	Division: Community Services Department: Development Services	Request Date	Adjustment Number
2012		11/27/2012	

BUDGET ADJUSTMENT DESCRIPTION / JUSTIFICATION

Move \$654 Raze and Removal funds from cancelled project #10033-1001 to current Raze and Removal project #10033-1204 for 320 North, and add \$4221 additional funding to the current project.

	<u>11/27/12</u> Date	Prepared By: <u>Rachel</u> rafiels
	<u>11-27-12</u> Date	Reference: _____
	<u>11.27.2012</u> Date	Budget & Research Use Only
	<u>11-29-2012</u> Date	Type: A B C D E P
	<u>12-3-12</u> Date	General Ledger Date _____
	<u>12/3/12</u> Date	Posted to General Ledger Initial _____ Date _____
		Checked / Verified Initial _____ Date _____

TOTAL BUDGET ADJUSTMENT 4,221 4,221

Account Name	Account Number		Increase / (Decrease)		Project.Sub Number
			Expense	Revenue	
Raze and Removals	1010.6420.5315.04	EX	4,875	-	10033 . 1204
Raze and Removals	1010.6420.5315.04	EX	(654)		10033 . 1001
Use of fund balance	1010.0001.4999.99	RI		4,221	.
					.
					.





Code Compliance Program Unsafe Building Violation Determination

Address / Location: 320 W. North St.

WC Parcel # 765-10576-000

I have determined that the structure above has become dilapidated, unsafe, unsanitary, or detrimental to the public welfare.

I recommend the raze and removal of the structure.

I recommend securing the structure.

Building Official

10 Apr 12

Observations: Since last inspection major deterioration of the house has occurred with roof sagging, soffit rotted out, section of the exterior walls rotten with exposed interior sections

I have determined that the structure above is not in violation of Subsection 173.09 (A) of the Fayetteville Code Of Ordinances.

Building Official

PLEASE RETURN THIS FORM TO CODE COMPLIANCE

Date Sent: March 26, 2012

SR# 117200

Date Received: 4/10/12

Case# _____

Community Services Division Director

City of Fayetteville
113 West Mountain Street
Fayetteville, Arkansas 72701



C. 1
Raze and Removal 320 W. North Street
Office of Code Compliance
Phone 479-575-8260
Fax 479-444-3445

VIOLATION NOTICE

May 01, 2012

Owner **ROBERT W. WILKES**
2766 N. CLUB DR. #4

FAYETTEVILLE, AR 72703

RE: Property @ 320 W NORTH ST, Fayetteville, AR

WC Parcel # 765-10576-000

Case # 15155

Dear Property Owner:

It appears that your property contains a violation of the Fayetteville Unified Development Ordinance. It is our goal to notify and assist property owners to correct violations of city ordinances before taking actual enforcement actions. **If you need clarification of this notice or advice on how to correct the problem, please call our office at (479)575-8232.**

Suspected Violation That Needs Correction:

§173.09 Unsafe Buildings. No persons, partnership, corporation or association, hereinafter referred to as "owner", shall keep or maintain any house or building within the corporate limits of the City which has become dilapidated, unsafe, unsanitary, or detrimental to the public welfare.

How This Violation Can Be Voluntarily Corrected:

By making repairs as needed or razing the structure and remove all debris from the lot. A building permit may be required, based on review of the Building Safety Director.

Potential Penalties:

If this violation is not corrected within thirty (30) days from the service of this notice, you can be issued a Criminal Citation for the above violation and be summoned to appear in court. Our office can also suggest the structure be razed and removed. The costs shall be charged to the owner(s) of the property and the city shall have a lien against such property for such costs. If you disagree with our conclusion that your property contains a violation of our ordinances, you have the right to appeal to the appropriate City Board, Commission or City Council. Please see Chapter 155 of the Unified Development Code.

If the residence is owner occupied and meets certain income requirements, you may qualify for federal assistance under our Community Development Block Grant. For more information on this program, please call (479) 575-8270 or 575-8240.

Sincerely,

ROSCOE JOHNSON
Code Compliance Officer

Cc: file



Code Compliance Program
OFFICER DELIVERY FORM

Document: Notice of Violation: 173.09 Unsafe Buildings

Name and Address to Deliver: Robert Wilkes
2766 N Club Dr #4
Fayetteville, AR 72703

Owner/Occupant's Signature: 

Return of Service

I certify that I provided a true copy of the document described above to:

Name of Recipient: Robert Wilkes

Officer Name: Laura Wilson

Officer Signature: 

Delivery Date: 5/3/12



October 25, 2012

Robert W. Wilkes
2766 N. Club Drive #4
Fayetteville, AR 72703

RE: Enforcement of Fayetteville Code 173.09
Arkansas Code Ann. 14-56-203

NOTICE TO PROPERTY OWNERS

Pursuant to A.C.A. 14-56-203 at 173.09 of the Fayetteville Code, you are placed upon Notice that the Fayetteville City Council will conduct a public hearing to determine if the dwelling located at **320 W. North Street (Parcel #765-10576-000)**, should be Razed and Removed.

You are free to appear at this hearing to present any evidence or statements. If you need additional information concerning this process or if you have information that we are not aware of, please call the Code Compliance Office at (479) 575-8260.

The hearing will be part of a regular City Council meeting on December 18, 2012 beginning at 6:00 p.m. at the City Administration Building, 113 W. Mountain St, Fayetteville, AR 72701. The City Council Meetings are advertised in local newspapers and will contain an item concerning this hearing. You may also call the Fayetteville City Clerk's Office (479-575-8323) for information confirming the date of the public hearing.

Sincerely,



Chad Ball
Code Compliance Administrator

Cc: file



Code Compliance Program
OFFICER DELIVERY FORM

Document: Notice of Violation: 173.09 Unsafe Buildings

Name and Address to Deliver: Robert W Wilkes
2766 N Club Dr #4
Fayetteville, AR 72703

Owner/Occupant's Signature: 

Return of Service

I certify that I provided a true copy of the document described above to:

Name of Recipient: ROBERT WILKES

Officer Name: ADAM ROBERTS

Officer Signature: 

Delivery Date: 10/26/12

Record 1 of 1 Last Updated 11/25/12

Print Page

Parcel Number: **765-10576-000** Prev. Parcel Number: **143798-000-00** Type: **RI**
 Location: **320 W NORTH ST**
 Owner Name: **WILKES, ROBERT W**
 Mailing Address: **320 W NORTH FAYETTEVILLE AR 72703**
 Lot: **003** Block: Block: Block: **S-T-R: 09-16-30**
 Addition: **SANFORD-GREEN S/D**
 School District: **FAYETTEVILLE SCH, FAY** Tax District: **011**
 City: **FAYETTEVILLE**
 Legal: **LOT 3 80/151 0.25**
 Current Year A79 Credit Status: **V**
 Last Appraised: **2010**

	Appraised Value	Taxable Value
Land	67,500	13,500
Improvement	65,550	13,110
Total	133,050	26,610

Tax History

Year	Taxable Value	Ad Valorem Tax	Imp. Dist. Tax	Timber Tax	Voluntary Tax	A79 Credit Status	A79	Net Total Tax	Total Tax Paid	Payment Status
2011										DELINQUENT
2010										DELINQUENT
2009										DELINQUENT
2008	21,780	\$0.00	\$0.00	\$0.00	\$0.00	\$0.00	O	\$0.00	\$0.00	PAID
2007	20,790	\$0.00	\$0.00	\$0.00	\$0.00	\$0.00	O	\$0.00	\$0.00	PAID
2006	19,800	\$0.00	\$0.00	\$0.00	\$0.00	\$0.00	O	\$0.00	\$0.00	PAID
2005	18,975	\$0.00	\$0.00	\$0.00	\$0.00	\$0.00	O	\$0.00	\$0.00	PAID
2004	18,150	\$941.26	\$0.00	\$0.00	\$0.00	\$0.00	V	\$1,053.83	\$1,053.83	PAID
2003	16,500	\$873.84	\$0.00	\$0.00	\$0.00	\$0.00		\$1,065.77	\$1,065.77	PAID
2002	16,500	\$857.34	\$0.00	\$0.00	\$0.00	\$0.00		\$857.34	\$857.34	PAID
2001	16,049	\$833.91	\$0.00	\$0.00	\$0.00	\$0.00		\$833.91	\$833.91	PAID
2000	14,590	\$765.98	\$0.00	\$0.00	\$0.00	\$0.00		\$873.38	\$873.38	PAID
1999	14,590	\$747.01	\$0.00	\$0.00	\$0.00	\$0.00		\$747.01	\$747.01	PAID
1998	14,590	\$748.47	\$0.00	\$0.00	\$0.00	\$0.00		\$748.47	\$748.47	PAID
1997	14,590	\$748.47	\$0.00	\$0.00	\$0.00	\$0.00		\$748.47	\$748.47	PAID

Available Tax Payment Receipt(s)

Year	Receipt #	Payment Date	Ad Valorem Tax	Imp. Dist. Tax	Timber Tax	Voluntary Tax	Penalty Tax	Payment
2004	10430	12/5/2005	\$941.26	\$0.00	\$0.00	\$0.00	\$112.57	\$1,053.83
2003	10429	12/5/2005	\$873.84	\$0.00	\$0.00	\$0.00	\$191.93	\$1,065.77
2002	45106	5/20/2003	\$857.34	\$0.00	\$0.00	\$0.00	\$0.00	\$857.34
2001	13167	4/12/2002	\$833.91	\$0.00	\$0.00	\$0.00	\$0.00	\$833.91
2000	19675	2/12/2002	\$765.98	\$0.00	\$0.00	\$0.00	\$0.00	\$873.38
1999	6078	4/17/2000	\$747.01	\$0.00	\$0.00	\$0.00	\$0.00	\$747.01
1998	1440	3/11/1999	\$748.47	\$0.00	\$0.00	\$0.00	\$0.00	\$748.47

Deed History

Date	Deed Ref.	Grantee1	Grantee2	Deed Type	Sale Amount	Revenue Amount
7/15/2010	<u>2010-20117</u>	WILKES, ROBERT W		RD	0	
		NLB 2010-201177 RD NO REV				
1/12/2004	<u>2004-1279</u>	WILKES, ROBERT WRAY		EX	0	
		SS 2004-1279 EX NO REV				
7/15/1986	<u>1185-621</u>	WILKES, WRAY & MARY LILLIAN		WD	40,000	44.00
1/1/1985	<u>654-3</u>	HAMILTON, EUNICE C		WD	0	0.00

Structure Number	Occupancy Type	Construction Type	First Floor Living Area	Total Living Area	Year Constructed	Basement Area
1	SF	FS	1317	1557	1941	

Grade	Condition	Exterior Wall	Fireplace	Year Remodeled	Effective Age
4	A	FS	1SA		69

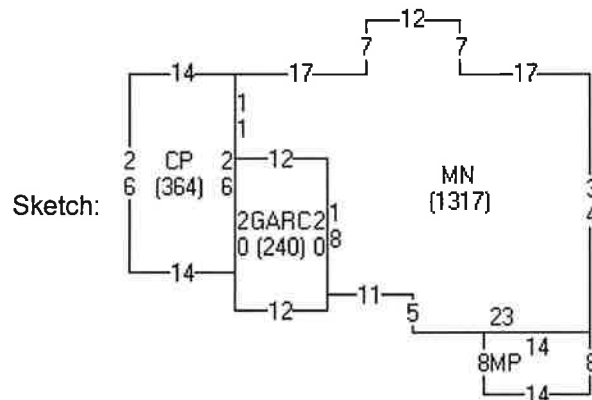

Out Buildings and Yard Improvements

Qty	Description	Size	Quality
1	Driveway, concrete	60x8	

[Next Item](#) |
 [Previous Item](#) |
 [Ledger Card](#) |
 [Prev. Ledger Card](#) |
 [Plat](#) |
 [GIS Parcel Map](#) |
 [Return to Search Results](#) |
 [Modify Search](#) |
 [New Search](#)





