

City Council Agenda Items
and
Contracts, Leases or Agreements

August 21, 2012

City Council Meeting Date
Agenda Items Only

Terry Gulley
Submitted By

Transportation
Division

Transportation Services
Department

Action Required:

An ordinance waiving the requirements of formal competitive bidding for the purchase of seventeen (17) Dynamic Lighting, Inc. light poles and fixtures and approving a purchase from Amerlux Exterior, LLC for the amount of \$26,010.00 plus sales tax.

\$ 28,415.93
Cost of this request
4470.9470.5418.00
4470.9470.5814.00
Account Number
02053 / 1
Project Number

\$ 1,491,380.00
Category / Project Budget
\$ 323,417.15
Funds Used to Date
\$ 1,167,962.85
Remaining Balance

Sidewalk Improvements
Program Category / Project Name
Transportation Improvements
Program / Project Category Name
Sales Tax Capital Improvements
Fund Name

Budgeted Item

Budget Adjustment Attached

Terry Gulley
Department Director

7-24-12
Date

Previous Ordinance or Resolution #

Eric B. Kelley
City Attorney

7-25-12
Date

Original Contract Date:

Original Contract Number:

Paul a. Behr
Finance and Internal Services Director

7-25-2012
Date

Received in City Clerk's Office 07-25-12 P01:40 RCVD
King

Terry Gulley
Chief of Staff

7-26-12
Date

Received in Mayor's Office
ENTER 7/25/12
PH

David D. Jordan
Mayor

7/27/12
Date

Comments:

CITY COUNCIL AGENDA MEMO

To: Mayor and City Council

Thru: Don Marr, Chief of Staff

From: Terry Gulley, Transportation Services Department Director *TG*

Date: August 21, 2012

Subject: Bid Waiver for Light Poles & Fixtures

PROPOSAL:

Staff proposes an ordinance waiving the requirements of formal competitive bidding for the purchase of light poles and fixtures needed to complete the improvements project currently under construction in downtown Fayetteville, including Mountain Street, College Avenue, Center Street, East Avenue, and Meadow Street.

RECOMMENDATION:

In order to remain consistent with the existing light poles and fixtures in the downtown area, the purchase of materials manufactured by Dynamic Lighting, Inc. and distributed by Amerlux Exterior, LLC will be necessary.

Staff recommends waiving the requirements of formal competitive bidding and approving the purchase of 17 Dynamic Lighting, Inc. poles and fixtures from Amerlux Exterior, LLC for a unit price of \$1,530.00 and a total purchase amount of \$26,010.00, plus sales tax.

BUDGET IMPACT:

Funds for the acquisition of light poles and fixtures are budgeted in the Sidewalk Improvements capital project.

ORDINANCE NO. _____

AN ORDINANCE WAIVING THE REQUIREMENTS OF FORMAL COMPETITIVE BIDDING AND APPROVING AN AGREEMENT WITH AMERLUX EXTERIOR, LLC FOR THE PURCHASE OF SEVENTEEN (17) STREETLIGHT POLES AND FIXTURES MANUFACTURED BY DYNAMIC LIGHTING, INC. IN THE TOTAL AMOUNT OF \$28,415.93 FOR INSTALLATION ON DOWNTOWN IMPROVEMENT PROJECTS ALONG MOUNTAIN STREET, COLLEGE AVENUE, CENTER STREET, EAST AVENUE AND MEADOW STREET

WHEREAS, the City desires to complete an improvements project currently under construction in downtown Fayetteville, including along Mountain Street, College Avenue, Center Street, East Avenue and Meadow Street; and

WHEREAS, in order to remain consistent with existing, previously installed streetlight poles and fixtures in the downtown area, the purchase of additional matching streetlight poles and fixtures manufactured by Dynamic Lighting, Inc. and distributed by Amerlux Exterior, LLC is necessary;

NOW, THEREFORE, BE IT ORDAINED BY THE CITY COUNCIL OF THE CITY OF FAYETTEVILLE, ARKANSAS:

Section 1. That the City Council of the City of Fayetteville, Arkansas hereby finds that such circumstances constitute an exceptional situation where competitive bidding is deemed not feasible or practical, and therefore waives the requirements of formal competitive bidding and authorizes an agreement with Amerlux Exterior, LLC for the purchase of seventeen (17) streetlights and poles manufactured by Dynamic Lighting, Inc. in total amount of \$28,415.93.

PASSED and APPROVED this 21st day of August, 2012.

APPROVED:

ATTEST:

By: _____
LIONELD JORDAN, Mayor

By: _____
SONDRA E. SMITH, City Clerk/Treasurer

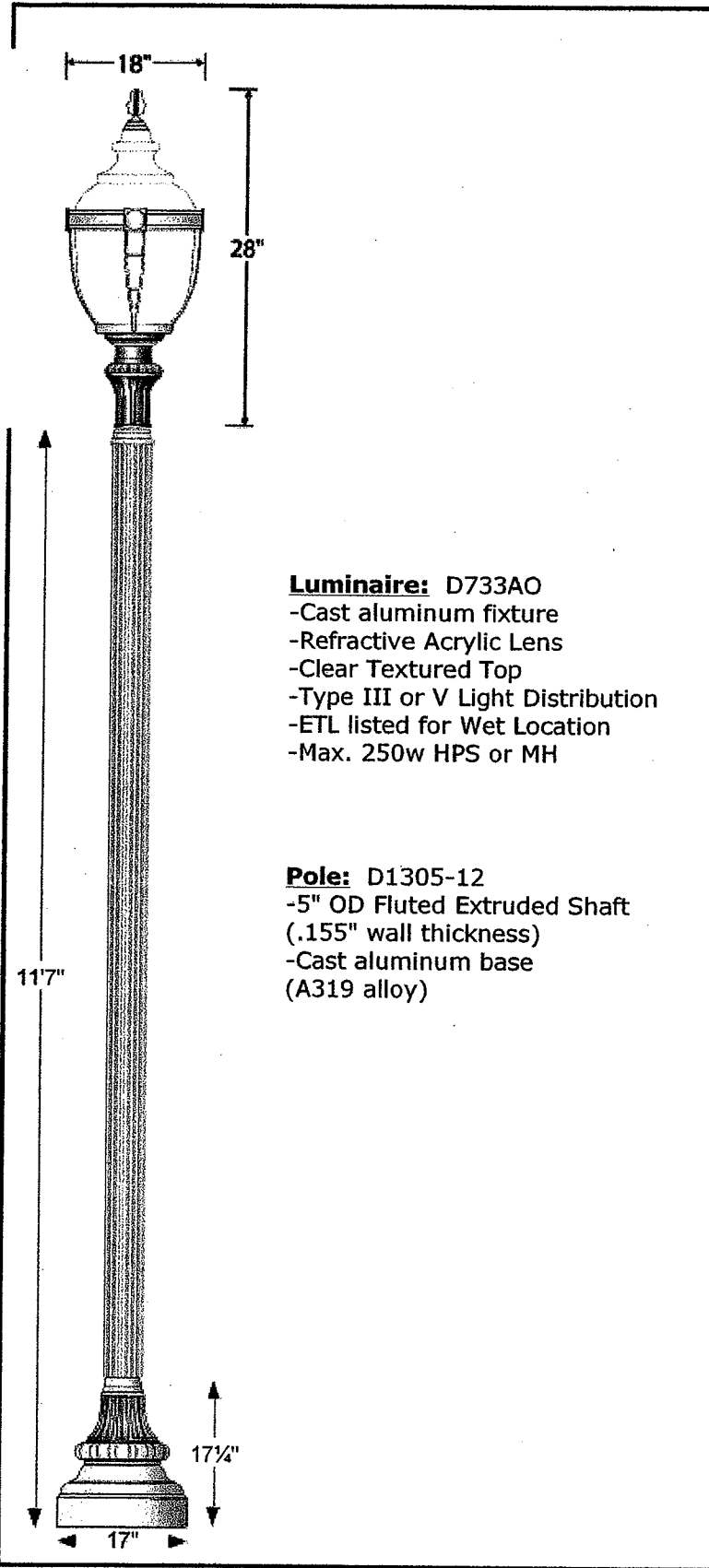

Luminaire: D733AO
 -Cast aluminum fixture
 -Refractive Acrylic Lens
 -Clear Textured Top
 -Type III or V Light Distribution
 -ETL listed for Wet Location
 -Max. 250w HPS or MH

Pole: D1305-12
 -5" OD Fluted Extruded Shaft
 (.155" wall thickness)
 -Cast aluminum base
 (A319 alloy)

DYNAMIC LIGHTING INC.
 5220 Shank Road
 Pearland, Texas 77581
 (800) 364-0098
 (281) 997-5400
 (281) 997-5441 Fax
 www.dynamiclighting.com

Luminaire
 D733AO
Light Source
 175 MH
Voltage
 120 208 240
 277 480 Other

Bracket

Pole
 D1305-12

Finish
 Undecided
 No selection made

Accessories

Please Note
 Due to the nature of the selection process and limitations of our web based system the information contained on this sheet must be confirmed with the factory before being used as a formal specification sheet.

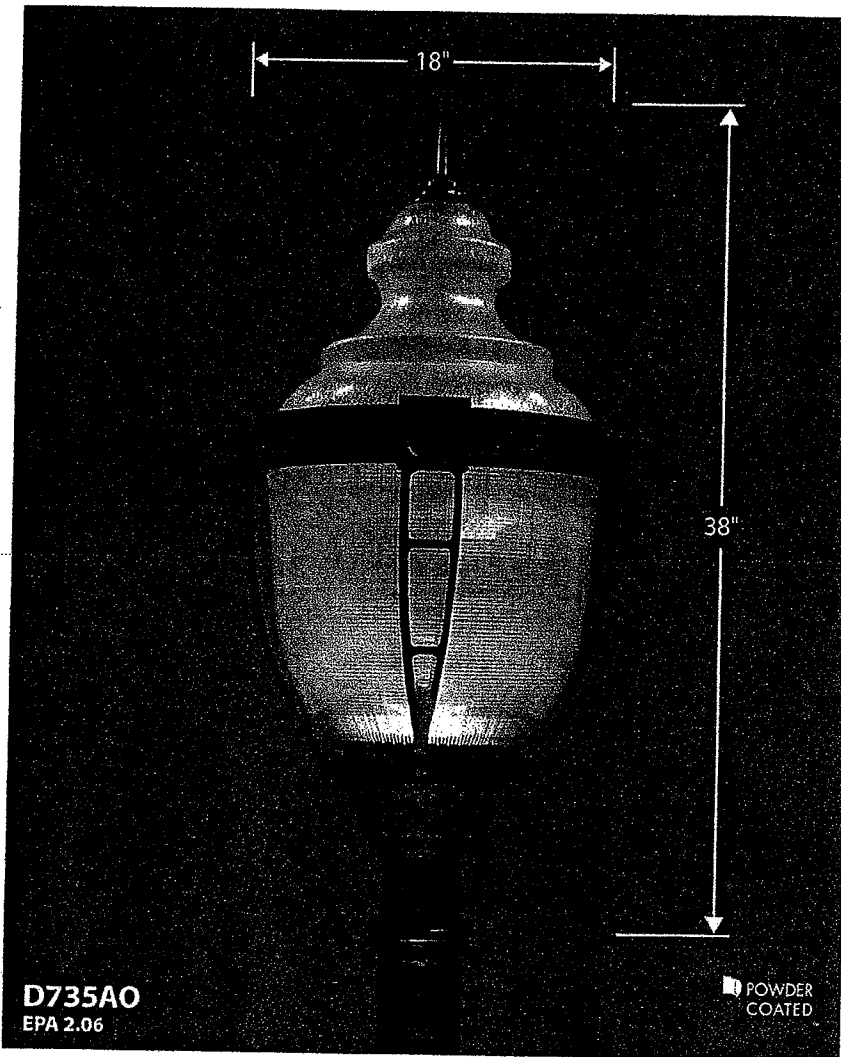

DESCRIPTION

The **D730AO** Series consists of a refractive Acrylic or optional Polycarbonate acorn surrounded by a decorative cage with a choice of cast aluminum fitters. An available perforated light reflector can help minimize light to the upper hemisphere. It offers state-of-the-art optical technology and nostalgic styling.

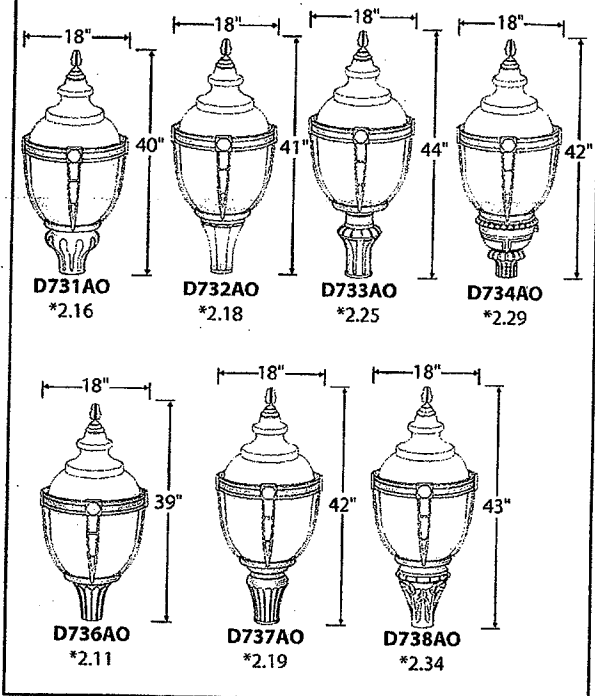

SPECIFICATIONS

MATERIALS

The fixture base, cage assembly and finial are cast aluminum. All hardware is stainless steel, and exterior hardware is tamper resistant. The highly efficient refractive lens will be molded in Acrylic (standard) or Polycarbonate (optional).

FINISH

The fixture will be finished with a premium quality thermoset polyester powdercoat for a durable finish.

Standard solid colors are:

- GRN** - Green
- WHT** - White
- CLB** - Classic Bronze

Premium finishes are:

- GTG** - Granite Green

- TBK** - Textured Black
- BLK** - Satin Black

- ATC** - Antique Copper

INSTALLATION

The luminaire will mount to a 3" OD post or tenon with 5/16" cone point stainless steel set screws to ensure a solid connection. The diffuser will be held to the fitter by (4) 5/16" stainless steel socket set screws.

ELECTRICAL

The easily accessible ballast will be High Power Factor (HPF), core and coil type, pre-wired and tested. The ballast can be removed by loosening two set screws and releasing the quick disconnect wiring harness. The glazed white porcelain socket will be medium or mogul base, 4KV pulse rated with a copper alloy nickel plated screw shell and center contact. All components are UL recognized and will be an integral part of the luminaire. The luminaire will carry an ETL label "Suitable for wet location".

DIFFUSER

The fixture will have a high performance refractive lens molded in (standard) Acrylic or (optional) Polycarbonate. Type III or V distribution is available in either material. Specify material and distribution type as shown below.

Standard

- AC - T3** (Acrylic Type III)
- AC - T5** (Acrylic Type V)

Optional

- PC - T3** (Polycarbonate Type III)
- PC - T5** (Polycarbonate Type V)



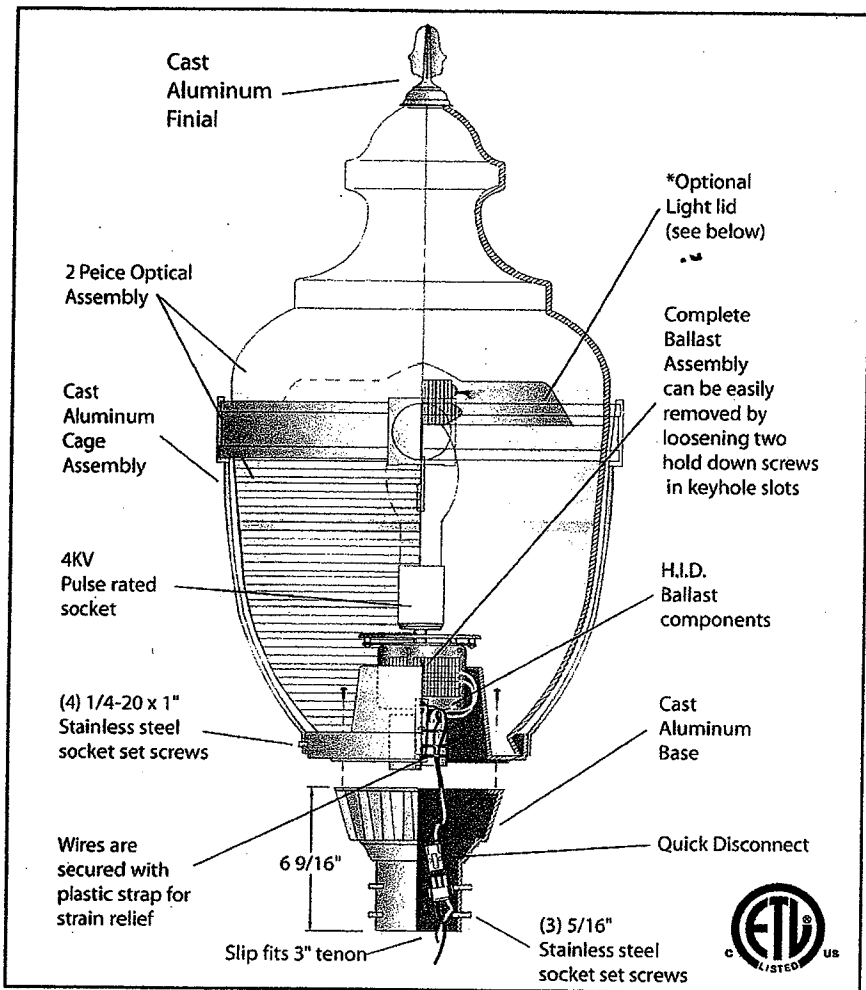

Standard Photometrics

D735AO

with 175MH lamp
14,000 Lumen
12' Mounting Height
Grid Spacing is 12'

Type V(T5)

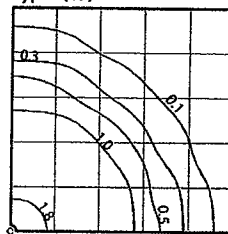

Type III(T3)

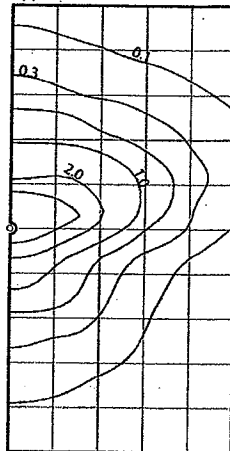

Ordering Guide (see "Accessories" for option details)

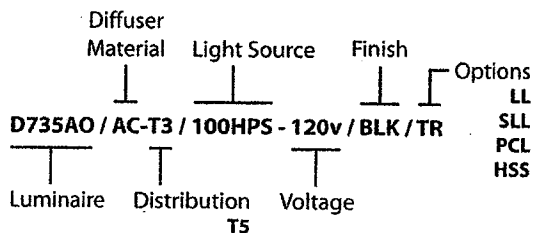

***OPTIONAL REFLECTOR** (specify part # LL or SLL after fixture)
The SLL is a solid light lid that minimizes uplight. The LL is a perforated reflector that minimizes uplight while providing an aesthetically pleasing glow to the top of the diffuser.

Order Code	Description	Voltage	Ballast Circuit Type	Min. Starting Temperature	Standard Socket
50MH	50 watt Metal Halide	120, 277	R / HX*	-20°F	Medium
70MH	70 watt Metal Halide	120, 208, 240, 277	HX	-20°F	Medium
100MH	100 watt Metal Halide	120, 208, 240, 277	HX	-20°F	Medium
150MH	150 watt Metal Halide	120, 208, 240, 277	HX	-20°F	Medium
175MH	175 watt Metal Halide	120, 208, 240, 277	CWA	-20°F	Mogul
250MH *	250 watt Metal Halide	120, 208, 240, 277	CWA	-20°F	Mogul
50HPS	50 watt High Pressure Sodium	120, 277	R	-40°F	Medium
70HPS	70 watt High Pressure Sodium	120, 208, 240, 277	R	-40°F	Medium
100HPS	100 watt High Pressure Sodium	120, 208, 240, 277	R / HX*	-40°F	Medium
150HPS	150 watt High Pressure Sodium	120, 208, 240, 277	R / HX*	-40°F	Mogul
250HPS *	250 watt High Pressure Sodium	120, 208, 240, 277	CWA	-40°F	Mogul
PL-13 or (2)PL-13	13 watt Compact Fluorescent	120, 277	MAGNETIC	20°F	2 - pin
Q28	28 watt Compact Fluorescent	120, 277	MAGNETIC	-20°F	2 - pin
CFL 26, 32, or 42	Compact Fluorescent	120, 208, 240, 277	ELECTRONIC	0°F	4 - pin

Ballast Circuit Type Codes: R - Reactor HX - High Reactance Autotransformer CWA - Constant Wattage Autotransformer (R / HX* depends on voltage selected)
480v is available on some light sources. Contact factory for details.

* Not Available In D735AO

5220 Shank Road • Pearland, Texas 77581 • 800.364.0098 • Fax: 281.997.5441

www.dynamiclighting.com

LU-B-16



City Of Fayetteville - Purchase Order (PO) Request

(Not a Purchase Order)

**All purchases under \$2500 shall be used on a P-Card unless medical or 1099 service related. (Call x256 with questions)
All PO Request shall be scanned to the Purchasing e-mail: Purchasing@ci.fayetteville.ar.us**

Requisition No.:	Date: 8/21/2012	C. 1 Amerlux Exterior, LLC
P.O Number:	Expected Delivery Date: Page 8 of 12	

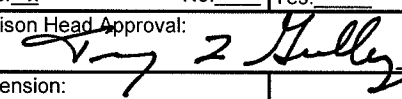
Vendor #: 20058	Vendor Name: Amerlux Exterior LLC	Mail Yes: <input type="checkbox"/> No: <input checked="" type="checkbox"/> x	
Address: 5220 Shank Rd.		Fob Point:	Quotes Attached Yes: <input checked="" type="checkbox"/> No: <input type="checkbox"/> x
City: Pearland	State: Texas	Zip Code: 77581	Ship to code: 104
Requester: Carolyn Smith		Requester's Employee #: 2644	Division Head Approval: 
		Extension: 348	

Item	Description	Quantity	Unit of Issue	Unit Cost	Extended Cost	Account Numbers	Project/Subproject #	Inventory #	Fixed Asset #
1	Poles & Fixtures for Downtown Improvements	6	Ea	1,530.00	\$9,180.00	4470.9470.5418.00	02053 / 1		
2	Poles & Fixtures for Downtown Improvements	11	Ea	1,530.00	\$16,830.00	4470.9470.5814.00	02053 / 1		
3					\$0.00				
4					\$0.00				
5					\$0.00				
6					\$0.00				
7					\$0.00				
8					\$0.00				
9					\$0.00				
10					\$0.00				
*	Shipping/Handling		Lot		\$0.00				

Special Instructions:
Sole Source Justification Attached
Mountain St. (Alley to College Ave.) (3) College Ave. (Center St. to Mountain St.) (3)
Center St. (Alley to College Ave.) (7) East Ave. (Meadow St. to Center St.) (2) Meadow St. (East Ave. to College Ave.) (2)

Subtotal:	\$26,010.00
Tax:	\$2,405.93
Total:	<u>\$28,415.93</u>

Approvals:

Mayor: _____	Department Director: _____	Purchasing Manager: _____
Finance & Internal Services Director: _____	Budget Manager: _____	IT Manager: _____
Dispatch Manager: _____	Utilities Manager: _____	Other: _____

Date: Jul 18, 2012

Quote: PLGSPR12-5286-1

Quote

Page 1/1



Premier Lighting Group
8040 B Counts Massie RD
North Little Rock AR 72113
Phone: (501) 753-6599
Fax: (501) 753-6567
From: Justin Long
Quoter Ph: [(501) 753-6599x201]
email: justinlong@premier-ltg.com

Project CITY OF FAYETTEVILLE / DOWNTOWN IMPROVEMENTS

Location

Quote PLGSPR12-5286-1

To: Carolyn Smith
CITY OF FAYETTEVILLE
113 WEST MOUNTAIN
FAYETTEVILLE AR 72701

For
Bid Date Jul 18, 2012
Expires Aug 17, 2012

Remarks:

NOTE: NO CUSTOM COLOR FEE IF ORDERED AT THE SAME TIME AS QUOTE#PLGSPR12-5272 AS DISCUSSED

QTY	Type	MFG	Part	Price	UQ	ExtPrice
17		AMERLUX EXT	D1305-12/CST/D733AO/AC-T3/175MH-MT-240/SLLFDR/CST CUSTOM COLOR - OFG BROWN GRAY-IFS PRSS 71503	\$1,530.00		\$26,010.00
Total:						\$26,010.00

Terms and conditions of sale:

PLEASE INCLUDE QUOTE # WITH ALL REMITTANCE.

SOLE SOURCE JUSTIFICATION

PURPOSE:

This form, with one or more categories completed, must accompany purchase requisitions for the sole source procurement of equipment, services or supplies exceeding \$1000 (purchased from State Contract vendors excepted). The purpose of sole source justification is to show that competitive bidding is impractical because only one product or service provider can meet a specific need. Therefore, an equitable evaluation of comparable products or services must be made and documented by the requester who shows that rejection of other products or services is based solely on their failure to meet that need. In cases where no other comparable source can be identified, a technical description of the product requested and a listing of those companies which were considered as alternative sources must be provided. Quality can be a subjective evaluation based upon opinion. Municipal (public) procurement law requires price considerations be evaluated via competitive quoting or bidding.

While all sole source justifications are subject to review, sole source justified purchases of \$20,000.00 or more must be publicly bid or a bid waiver approved by Council. Justifications must contain clear, in-depth, and accurate information in order to avoid protests and the possibility of delaying the procurement.

INSTRUCTIONS:

1. Please type or print legible in ink.
2. Complete all categories and sections that apply.
3. Provide full explanation, complete descriptions, and/or list all relevant reasons where space has been provided. Sole Source Justification forms lacking sufficient detail cannot be approved.
4. Sign and date the form in the space provided for "signature".
5. Improperly completed, and/or unsigned forms will be returned to the sender.

TO: Purchasing Division Date: 8-8-11
FROM: Brad Anderson Dept: Transportation
Names of Requisitioner and Dept. Head
SUBJECT: Sole Source Justification
Purchase Requisition _____ (attached)
Proposed Vendor Premier Lighting Group Distributor for Amerlux Exterior
Product Description D737A0/AC-TS/DMH-240V/CC/FDR
fixture with D1305-14-5"OD Fluted-3" tenon custom
color pole (College Ave Decorative lighting)
(Square District Decorative lighting)

STATEMENT

I am aware that Fayetteville Code of Ordinances, Title III Administration, Chapter 34, Article II mandates that the procurement of services, materials, equipment and supplies be via competitive quotes whenever the amount is over \$1,000.00. However, I am requesting sole source procurement based on the following criteria. (Attach additional sheets as necessary):

1. The requested product is an integral repair part or accessory compatible with existing equipment. (please state the manufacturer and model number of existing equipment):

Dynamic Lighting parts - D733A0/AC-TJ/175MH-240V/CC/FDR
" " " - D1205-14-5"OD Fluted-3" tenon-CC

To match existing poles & fixtures

2. The requested product has special design/performance features which are essential to my needs.

Both A and B portions of this category must be completed.

A. These features are:

B. In addition to the product requested, I have contacted other suppliers and considered their product of similar capabilities. I find their product unacceptable for the following reasons (identify companies contacted, individuals contacted, model number and specific technical deficiency).

3. I have standardized the requested product/service; the use of another would require considerable time and money to evaluate.

Explain: Manufacturer specific design.

4. The requested product is one which I (or my staff) have specialized training and/or extensive experience. Retraining would incur substantial cost in money and/or time.

Explain: NA

5. Please consider sole source approval for this reason(s) (e.g. trade-in allowance; availability of services, parts and maintenance; product is a prototype; inventory of parts are maintained, etc.):

NA

Authorization:

Full Name and Title of Requisitioner Brad Anderson Testtic Control Sup.
(typed or printed in ink)

Signature [Signature] Date 8-8-11

Full Name of Division Head TERRY L. GULLY

(typed or printed in ink)

Signature [Signature] Date 8-8-11